

POS	Item Number	Description
1	Body	Stainless steel 1.4408
2	Bonnet	Stainless steel 1.4408
3	Ball	Stainless steel SS316
4	Seat	Stainless steel SS316
5	Stem	PTFE+SS316
6	Stem washer	PTFE
7	Gasket	PTFE
8	Bolt	SS316
9	Packing	PTFE
10	Gland nut	SS304

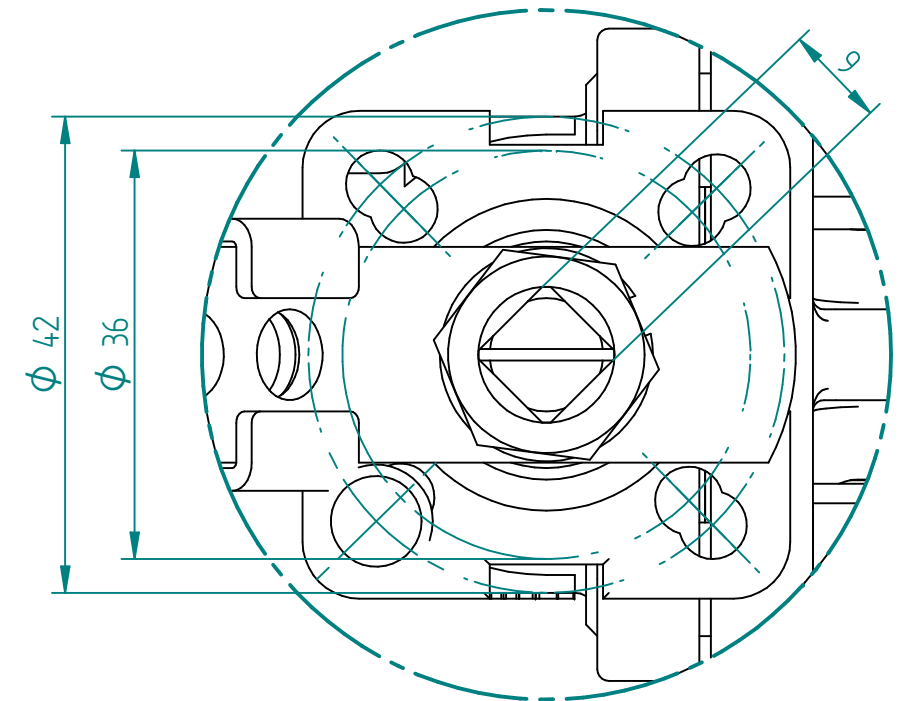

DETAIL A
ISO 5211 Mounting Pad
1,5:1

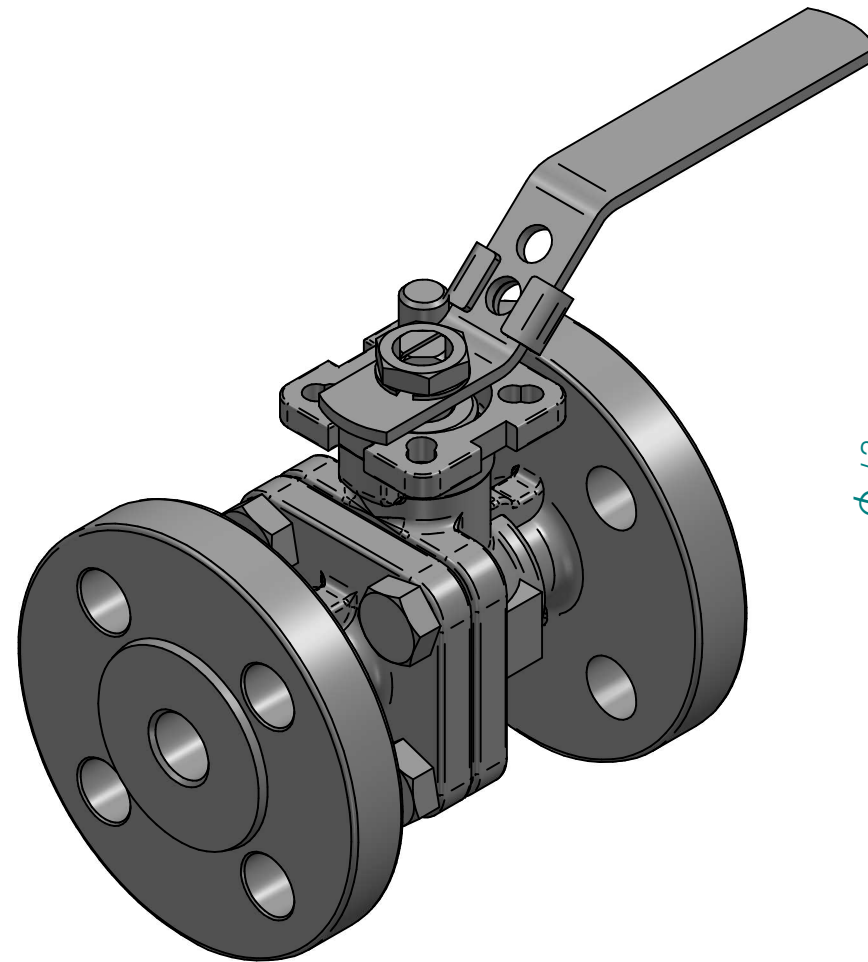
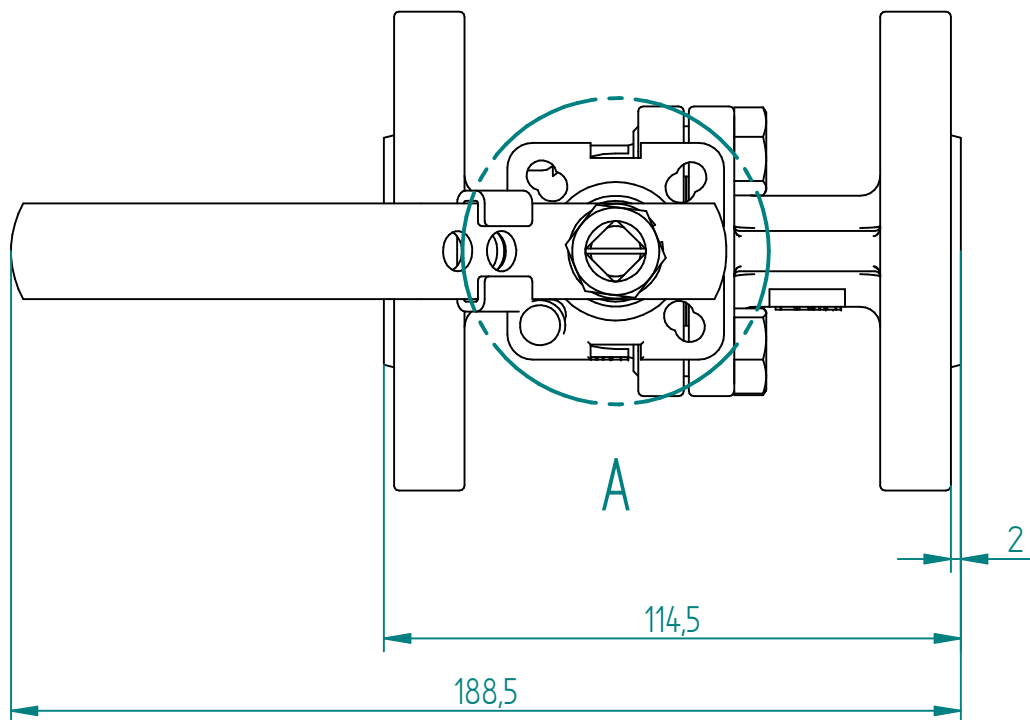

TITLE	DRAWN	NAME	DATE	SIZE	DWG NO	UNLESS OTHERWISE SPECIFIED DIMENSIONS ARE IN MILLIMETERS AND TOLERANCES ARE +/-0,5
	CHECKED	ORLA	06.04.2020		FILE NAME: YON-100-F60-0015.dft	
	ENG APPR	TOCO	dd.mm.yyyy	SCALE: 1:1,5	REV:	
	MGR APPR	TOCO	dd.mm.yyyy	WEIGHT:	SHEET: 1 OF 1	

REV	DESCRIPTION	DATE	APPROVED
REVISION HISTORY			