

POS	Item Number	Description
1	Body	Stainless steel 1.4408
2	Bonnet	Stainless steel 1.4408
3	Ball	Stainless steel SS316
4	Seat	Stainless steel SS316
5	Stem	PTFE+SS316
6	Stem washer	PTFE
7	Gasket	PTFE
8	Bolt	SS316
9	Packing	PTFE
10	Gland nut	SS304

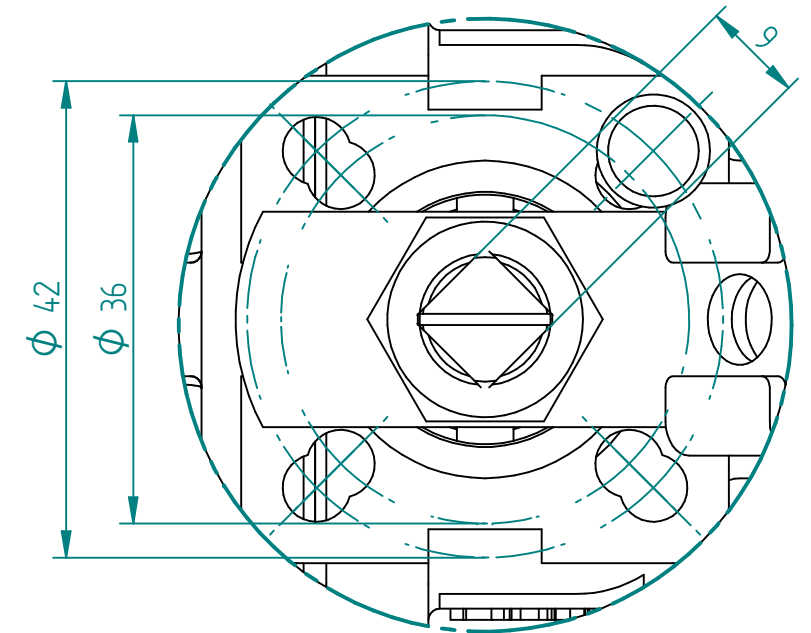

DETAIL A  
ISO 5211 Mounting Pad  
1,5:1

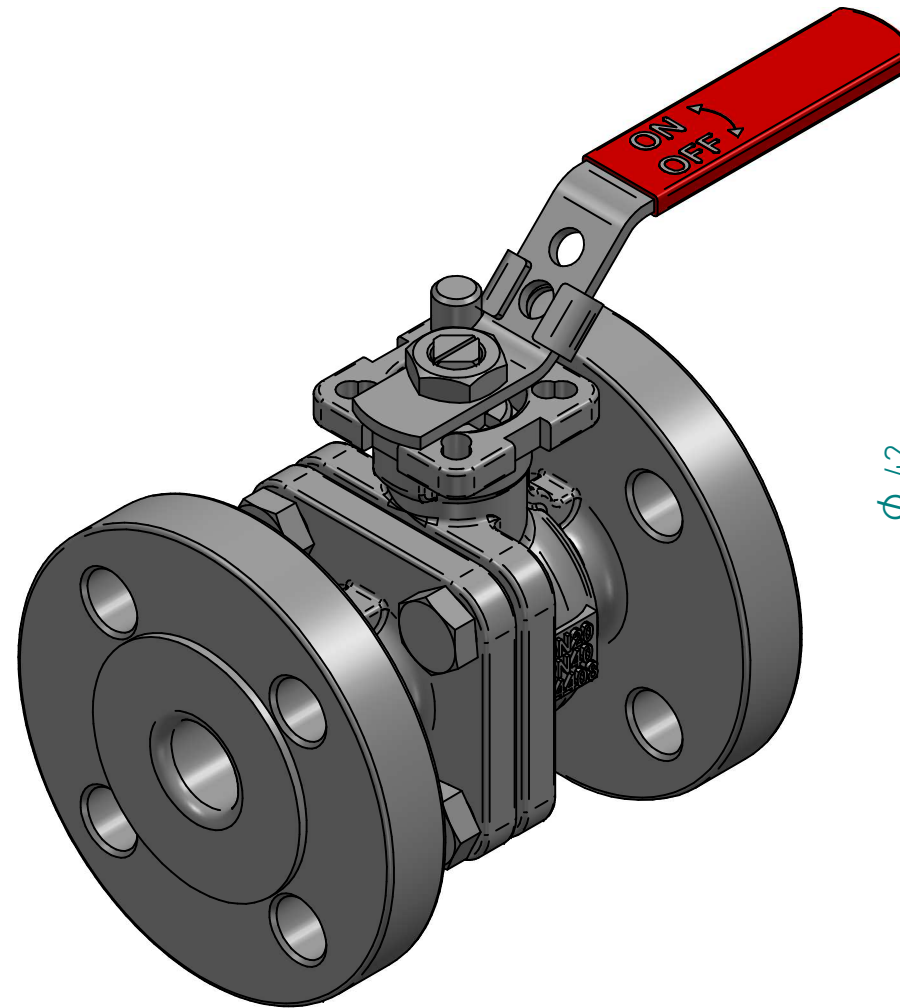
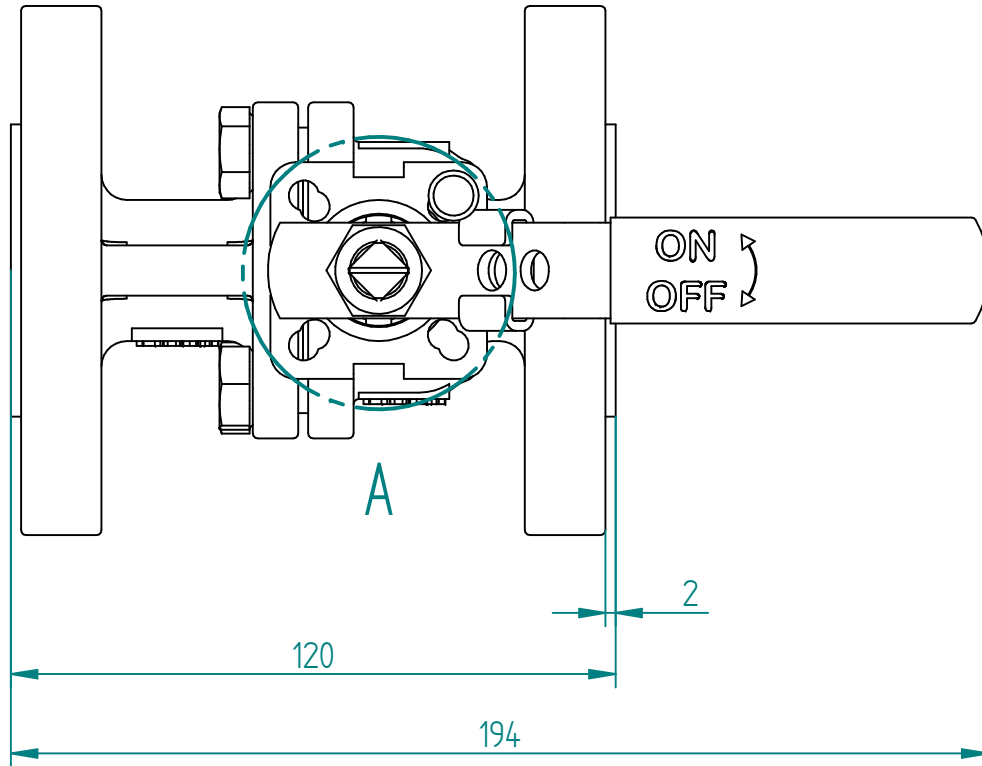

TITLE	DRAWN	NAME	DATE	SIZE	DWG NO	
				<b>A3</b>	YON-100-F30-0020	
				FILE NAME:	YON-100-F30-0020.pdf	
				SCALE:	1:1,5	
ENG APPR	TOCO	dd.mm.yyyy	SCALE:	1:1,5	REV:	.....
MGR APPR	TOCO	dd.mm.yyyy	WEIGHT:		SHEET:	1 OF 1

UNLESS OTHERWISE SPECIFIED DIMENSIONS ARE IN MILLIMETERS AND TOLERANCES ARE +/-0,5

REV	DESCRIPTION	DATE	APPROVED
REVISION HISTORY			

BALL VALVE V-PORT 30 DEG 3/4" FLANGED PN40 SS316 SQR 9 F03/F04 SS SEAT WITH LEVER