

POS	Item Number	Description
1	Body	Stainless steel 1.4408
2	Bonnet	Stainless steel 1.4408
3	Ball	Stainless steel SS316
4	Seat	Stainless steel SS316
5	Stem	PTFE+SS316
6	Stem washer	PTFE
7	Gasket	PTFE
8	Bolt	SS316
9	Packing	PTFE
10	Gland nut	SS304

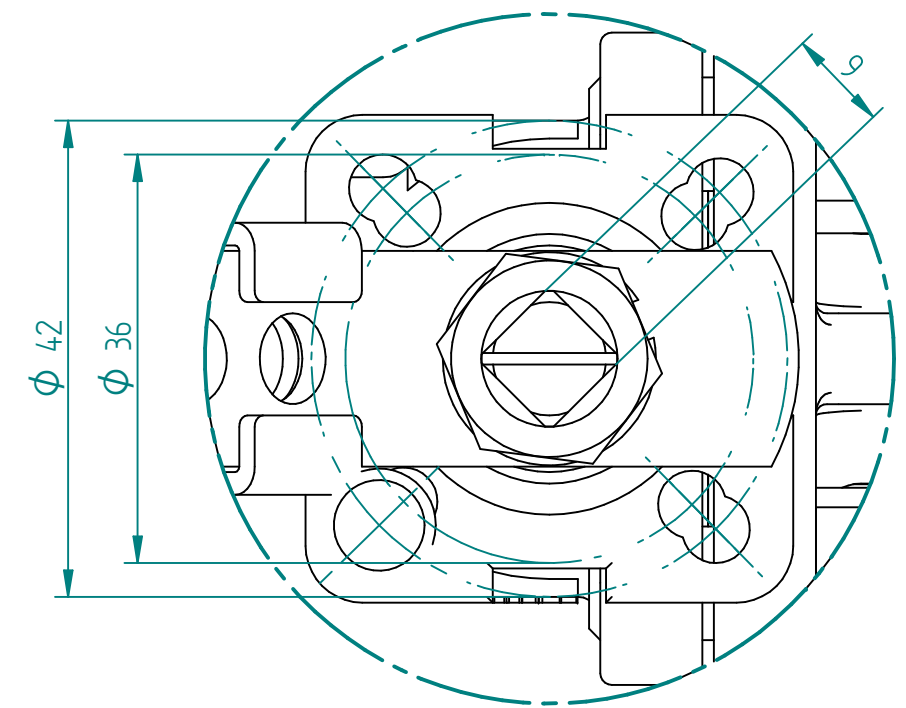

DETAIL A
ISO 5211 Mounting Pad
1,5:1

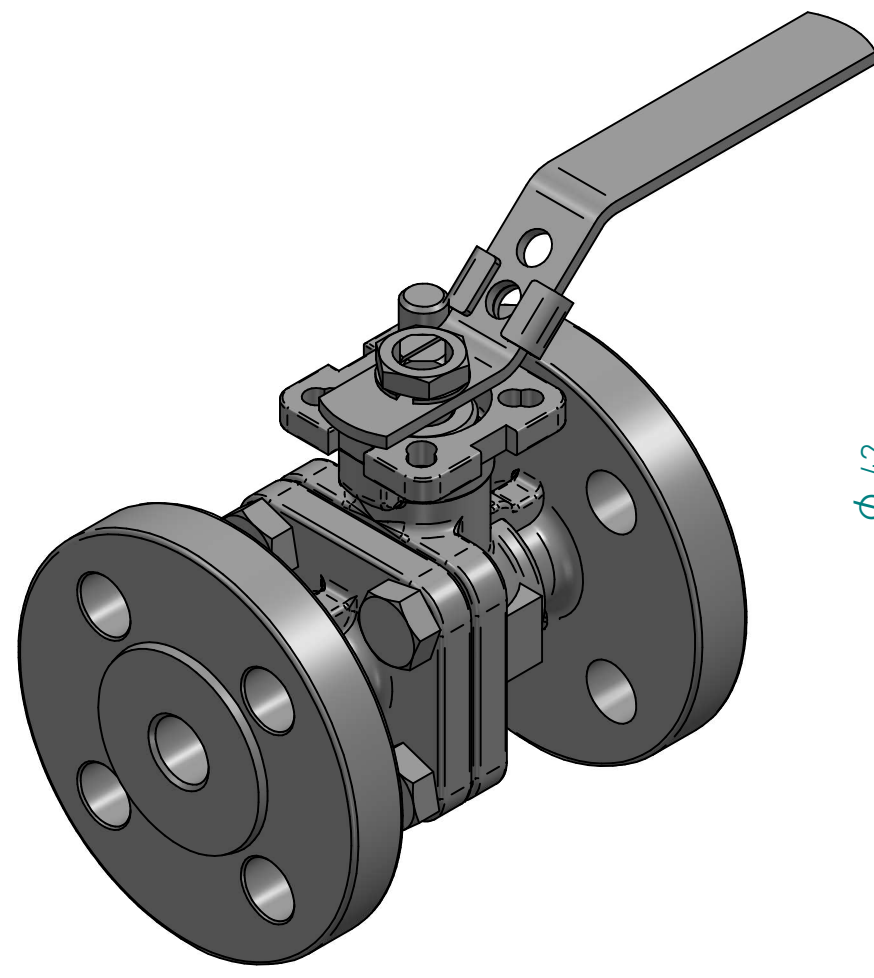
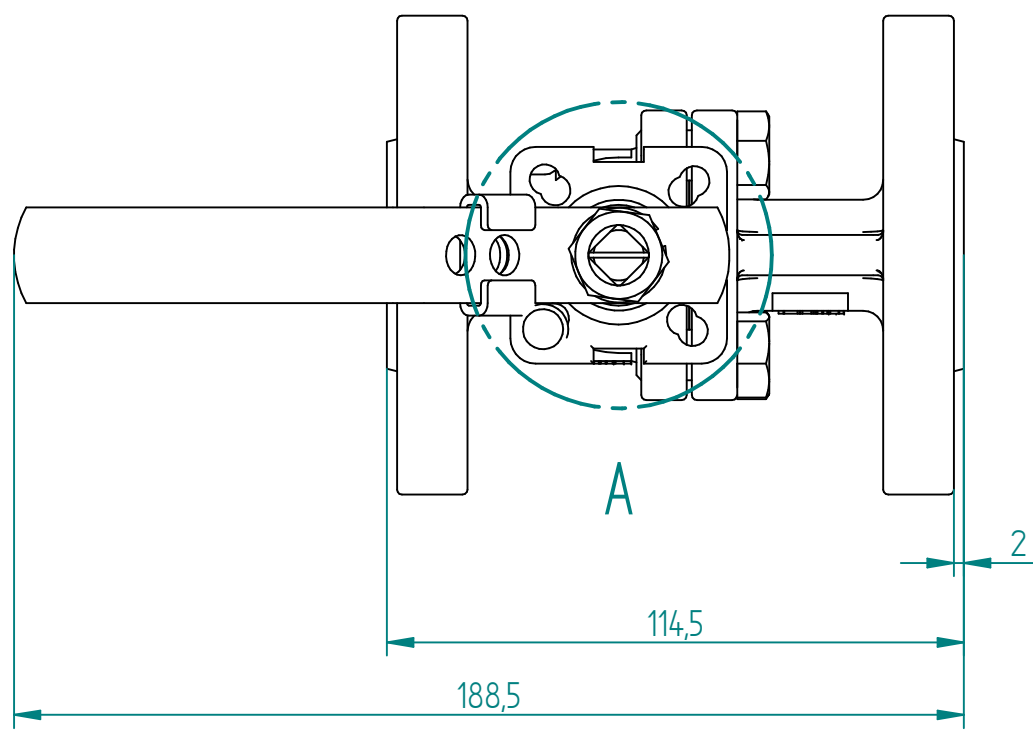

DRAWN	NAME	DATE	SIZE	DWG NO	
				MOTO	06.04.2020
CHECKED	ORLA	06.04.2020	FILE NAME: YON-100-F30-0015.dft		
ENG APPR	TOCO	dd.mm.yyyy	SCALE: 1:1,5	REV:	
MGR APPR	TOCO	dd.mm.yyyy	WEIGHT:	SHEET: 1 OF 1	

UNLESS OTHERWISE SPECIFIED DIMENSIONS ARE IN MILLIMETERS AND TOLERANCES ARE +/-0,5

TITLE BALL VALVE V-PORT 30 DEG 1/2" FLANGED PN40 SS316 SQR 9 F03/F04 SS SEAT WITH LEVER

REV	DESCRIPTION	DATE	APPROVED
REVISION HISTORY			