

POS	Item Number	Description
1	Body	ASTM A351 CF8M
2	Bonnet	ASTM A351 CF8M
3	Ball	Stainless steel (SS316)
4	Stem	Stainless steel (SS316)
5	Seat	50% PTFE+SS316
6	Washer	PTFE
7	Gasket	PTFE
8	Stem packing	PTFE
9	Ring	SS316
10	Belleville washer	SS301
11	Gland flange	CF8
12	O-ring	Viton

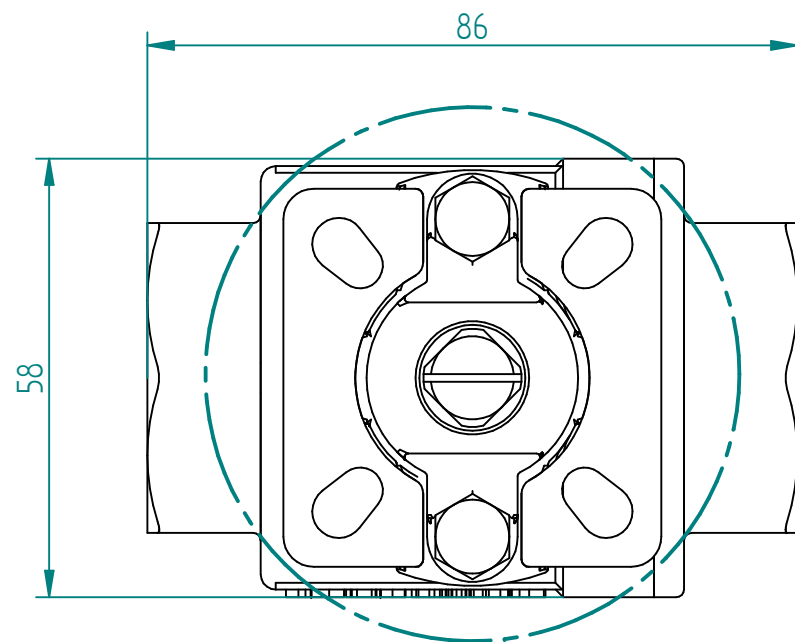

A

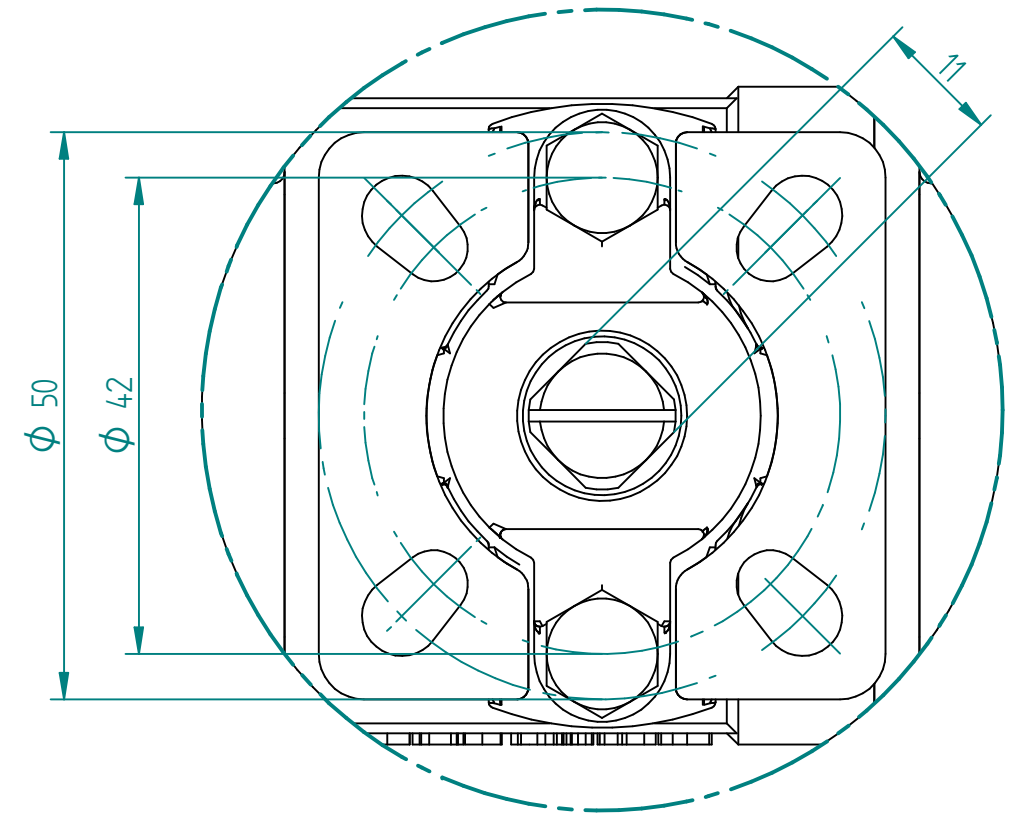
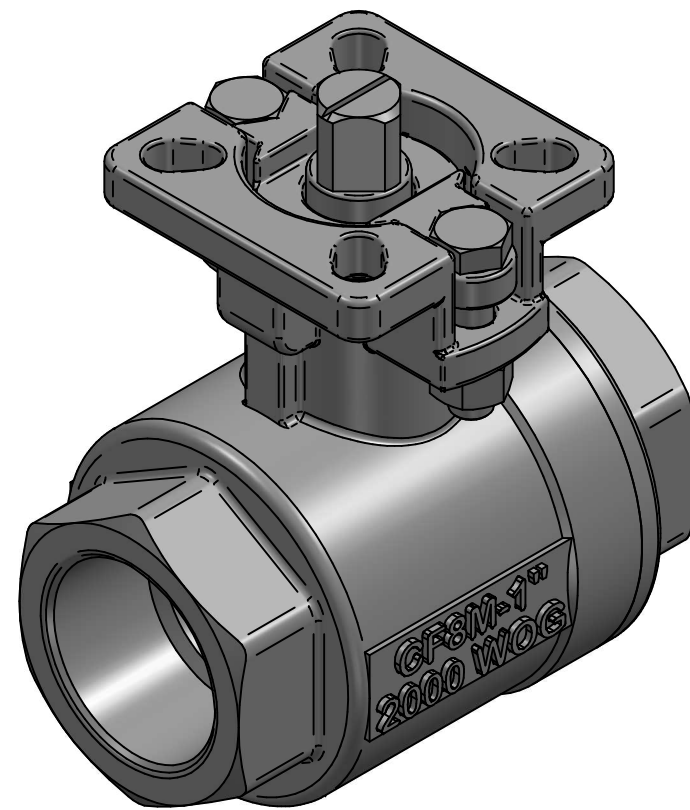

DETAIL A
ISO 5211 Mounting Pad
1,5:1



TITLE BALLVALVE V-PORT 60 DEG 1"
BSP 2000WOG SS316 2PC
SQR 11 F04/F05 50/50 SS SEAT

	NAME	DATE	SIZE	DWG NO
DRAWN	MOTO	06.04.2020	A3	YON-100-BSP60-0025
CHECKED	ORLA	06.04.2020	FILE NAME: YON-100-BSP60-0025.dft	
ENG APPR	TOCO	dd.mm.yyyy	SCALE: 1:1	REV:
MGR APPR	TOCO	dd.mm.yyyy	WEIGHT:	SHEET: 1 OF 1

UNLESS OTHERWISE SPECIFIED
DIMENSIONS ARE IN MILLIMETERS
AND TOLERANCES ARE +/-0,5

REV	DESCRIPTION	DATE	APPROVED
REVISION HISTORY			