

Pos	Part name	Material
1	Indicator bolt	304
2	Indicator	ABS/304
3	Circlip	304
4	Thrust washer	304
5	Outside washer	POM
6	Body	Alu 6005-T5
7	Piston guide	POM
8	O-ring (pinion top)	NBR
9	Bearing (pinion top)	POM
10	Inside wahser	POM
11	Cam	Steel #45
12	Pinion	Steel #45
13	Bearing (pinion bottom)	POM
14	O-ring (pinion bottom)	NBR
15	Bearing (piston)	POM
16	O-ring (piston)	NBR
17	Piston	Alu A380
18	Plug	NBR
19	O-ring (adjustment srew)	NBR
20	Nut (adjustment screw)	304
21	Adjustin screw	304
22	Stop bolt	304
23	Stop nut	304
24	O-ring (end cap)	NBR
25	End-cap	Alu A380
26	End-cap screw	304

WWF / Venus dual acting actuator

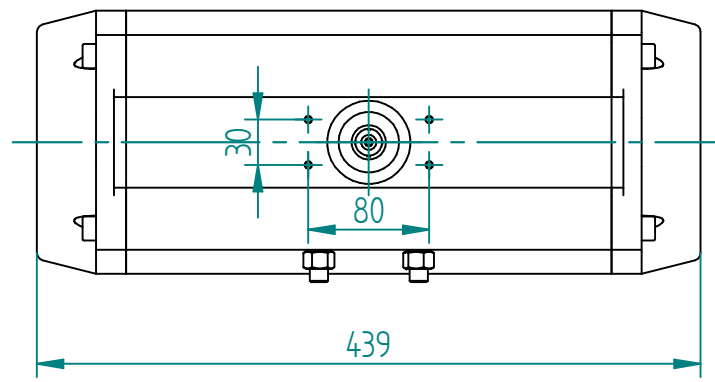
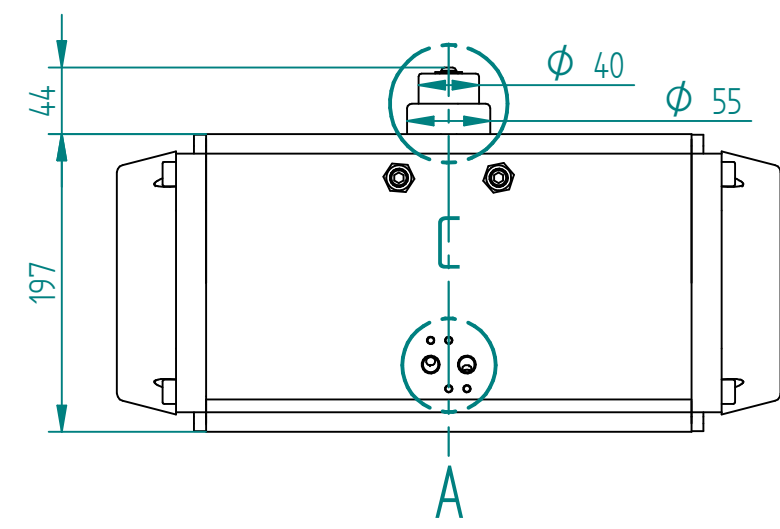
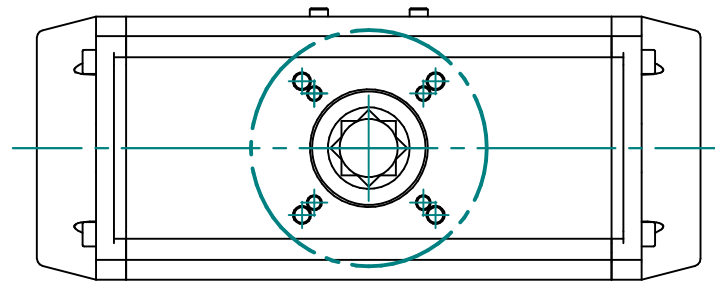
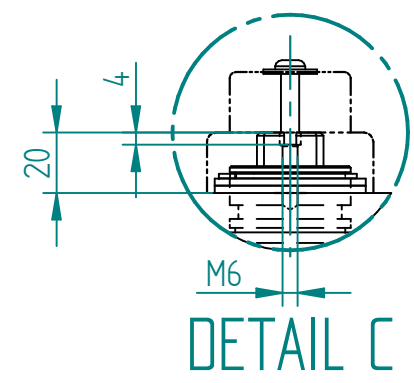
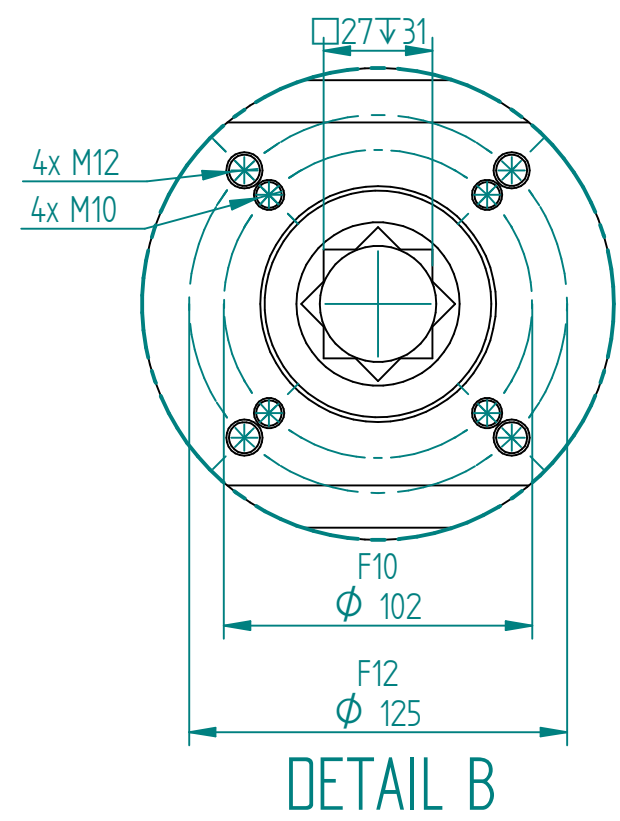
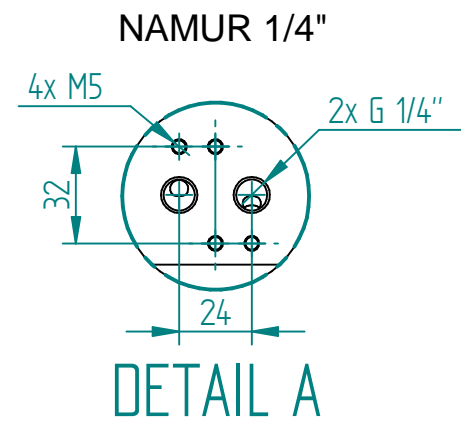
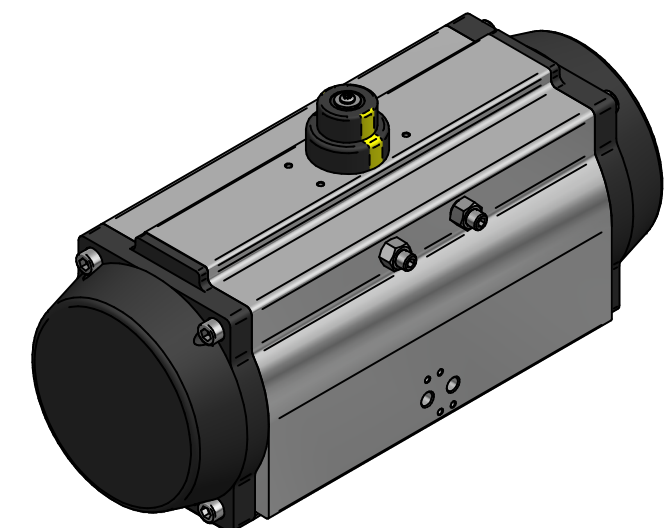

TITLE	VENUS 160 ACTUATOR DA F10/F12-SQ27X31		NAME	DATE	SIZE	DWG NO	UNLESS OTHERWISE SPECIFIED DIMENSIONS ARE IN MILLIMETERS AND TOLERANCES ARE +/-0,5
	BODY: ALU, NBR (-20 TIL 80°C)		EMLA	20.04.2024	A3	WWF-03VE160DA27	
	HARD ANODIZED, 798NM @ 6BARG		TOCO	dd.mm.yyyy	FILE NAME: WWF-03VE160DA27.dft		
			TOCO	dd.mm.yyyy	SCALE: 1:5	REV: 20.1 kg	
		TOCO	dd.mm.yyyy	WEIGHT: 20.1 kg	SHEET: 1 OF 1		

REV	DESCRIPTION	DATE	APPROVED
00	ISSUED	11.07.2024	EMLA
REVISION HISTORY			