

Pos	Part name	Material
1	Indicator bolt	304
2	Indicator	ABS/304
3	Circlip	304
4	Thrust washer	304
5	Outside washer	POM
6	Body	Alu 6005-T5
7	Piston guide	POM
8	O-ring (pinion top)	NBR
9	Bearing (pinion top)	POM
10	Inside wahser	POM
11	Cam	Steel #45
12	Pinion	Steel #45
13	Bearing (pinion bottom)	POM
14	O-ring (pinion bottom)	NBR
15	Spring	Spring steel
16	Bearing (piston)	POM
17	O-ring (piston)	NBR
18	Piston	Alu A380
19	Plug	NBR
20	O-ring (adjustment screw)	NBR
21	Nut (adjustment screw)	304
22	Adjustin screw	304
23	Stop bolt	304
24	Stop nut	304
25	O-ring (end cap)	NBR
26	End-cap	Alu A380
27	End-cap screw	304

WWF / Venus spring return actuator

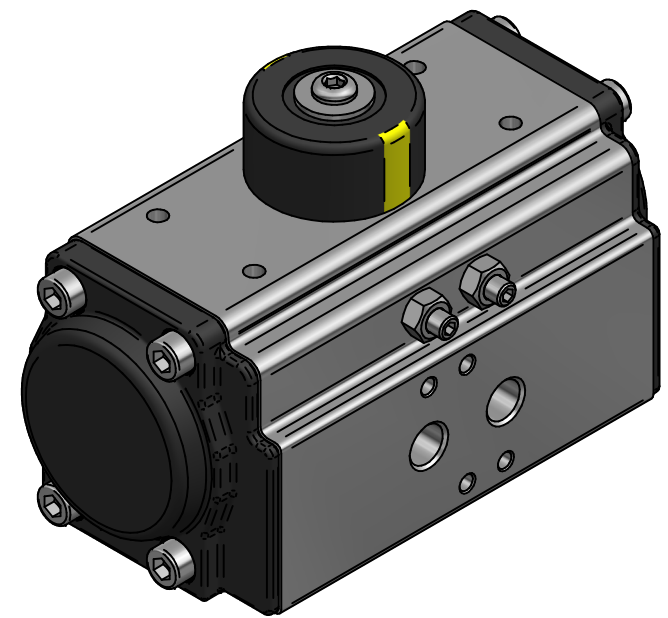

DRAWN	NAME	DATE	SIZE	DWG NO
	EMLA	27.03.2024	A3	WWF-03VE052SR11
CHECKED	EMLA	27.03.2024	FILE NAME: WWF-03VE052SR11.dft	
ENG APPR			SCALE: 1:2	REV: 00
MGR APPR			WEIGHT: 1.5 kg	SHEET: 1 OF 1

UNLESS OTHERWISE SPECIFIED DIMENSIONS ARE IN MILLIMETERS AND TOLERANCES ARE +/-0,5

REV	DESCRIPTION	DATE	APPROVED
00	ISSUED	11.07.2024	EMLA
REVISION HISTORY			

TITLE VENUS 52 ACTUATOR SR F03/F05-SQ11X14
 BODY: ALU, NBR (-20 TIL 80°C)
 HARD ANODIZED, 8,5NM @ 6BARG