

No.	Part Name	Material	Qty.
1	Bushing	PTFE	2
2	Upper Body	GGG40	1
3	Upper Shaft	SS431	1
4	Spring Planet	Spring Steel	8
5	Gland	Stainless Steel	2
6	O'ring	FKM	2
7	Seat Energizer	Silicone	2
8	Seat	PTFE/PFA	1
9	Disc	PTFE+WCB	1
10	Lower Shaft	SS431	1
11	Lower Body	GGG40	1
13	Bolt	SS316	2

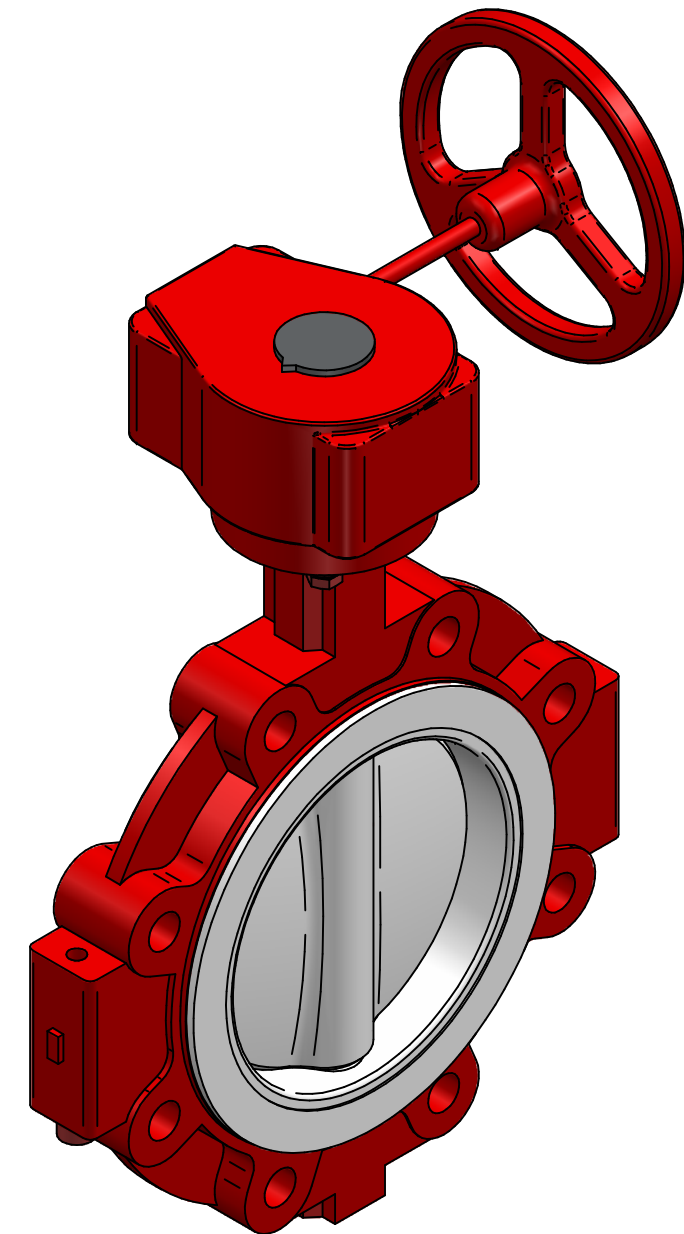

TITLE LT BUTTERFLY PTFE DN150 GGG40 PN 10/16 LUG  
WCB+PTFE DISC, SS431 SHAFT, PTFE SEAT  
DIN PN 10, IP65 WORM GEAR OPERATION 157Nm

	NAME	DATE	SIZE	DWG NO
DRAWN	RAGA	17.11.2023	A3	WOD-110-003-0150
CHECKED	TOCO	dd.mm.yyyy	FILE NAME: WOD-110-003-0150.dft	
ENG APPR	TOCO	dd.mm.yyyy	SCALE: 1:3	REV: 01
MGR APPR	TOCO	dd.mm.yyyy	WEIGHT:	SHEET: 1 OF 1

UNLESS OTHERWISE SPECIFIED  
DIMENSIONS ARE IN MILLIMETERS  
AND TOLERANCES ARE +/-0,5

REV	DESCRIPTION	DATE	APPROVED
01	Modified appearance	17.11.2023	RAGA
REVISION HISTORY			