

No.	Part Name	Material	Qty.
1	Bushing	PTFE	2
2	Upper Body	GGG40	1
3	Upper Shaft	SS431	1
4	Spring Planet	Spring Steel	8
5	Gland	Stainless Steel	2
6	O'ring	FKM	2
7	Seat Energizer	Silicone	2
8	Seat	PTFE/PFA	1
9	Disc	PTFE+WCB	1
10	Lower Shaft	SS431	1
11	Lower Body	GGG40	1
13	Bolt	SS316	2

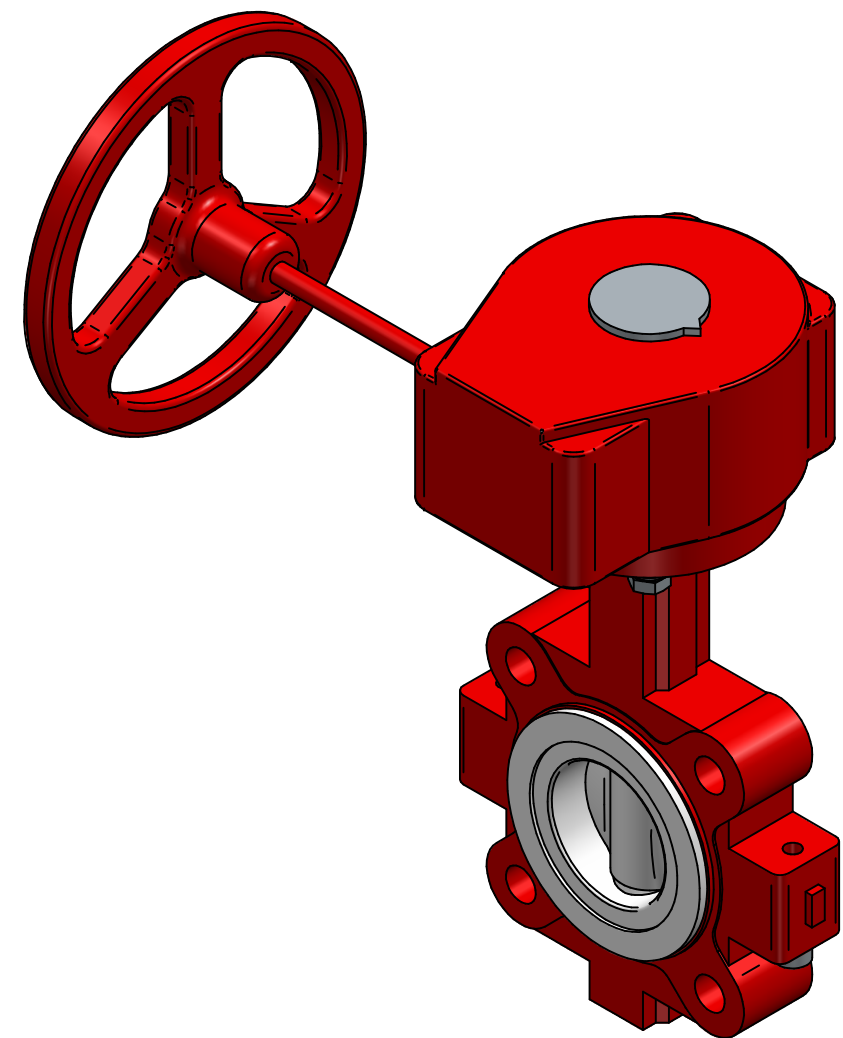

TITLE BF-VALVE CBF04-TL01 DN50 16BAR PN10/16 LUG
 CONC. DI/WCB+PTFE/SS431/PTFE F05/07 SQR9X14
 WRAS W/IP65 WORM GEAR 20NM/10BAR

	NAME	DATE	SIZE	DWG NO
DRAWN	RAGA	23/04/2024	A3	WOD-110-003-0050
CHECKED	ORLA	dd.mm.yyyy	FILE NAME: WOD-110-003-0050.dft	
ENG APPR	TOCO	dd.mm.yyyy	SCALE: 1:2.5	REV: 01
MGR APPR	TOCO	dd.mm.yyyy	WEIGHT:	SHEET: 1 OF 1

UNLESS OTHERWISE SPECIFIED
 DIMENSIONS ARE IN MILLIMETERS
 AND TOLERANCES ARE +/-0,5

REV	DESCRIPTION	DATE	APPROVED
02	Changed Description	23.04.2024	RAGA
REVISION HISTORY			