

# Vexve Type 243

## Balancing valves, stainless steel, with flange/flange ends

**Material**

- Body: Stainless steel, EN 10217-7 X2CrNiMo17-12-2(1.4404)
- Ball: Stainless steel, EN X2CrNiMo17-12-2(1.4404)
- Stem: Stainless steel, EN X2CrNiMo17-12-2(1.4404)
- Stem seals: FPM
- Ball seals: Hardened teflon
- Handle  
DN 15 - 150: Stainless steel  
DN 200 - 250: Manual gear

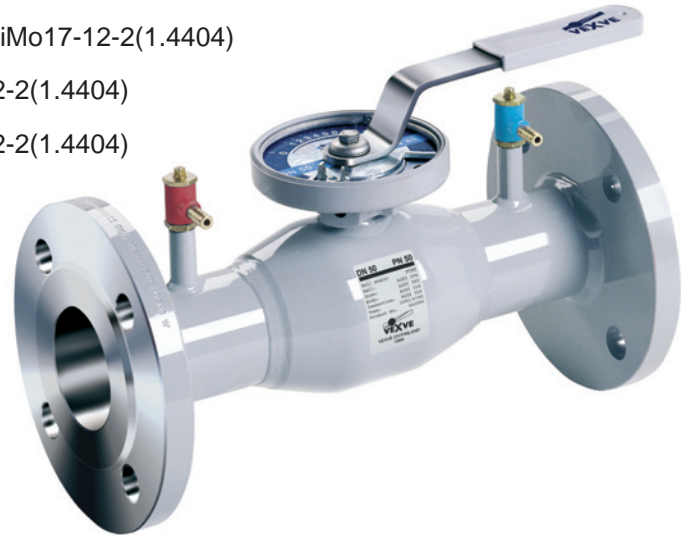

**Flanges**

EN 1092-1  
Available also PN10, 16, 25, 40

**Operating conditions**

Temperature: -30 °C - +200 °C  
below 0 °C contact manufacturer

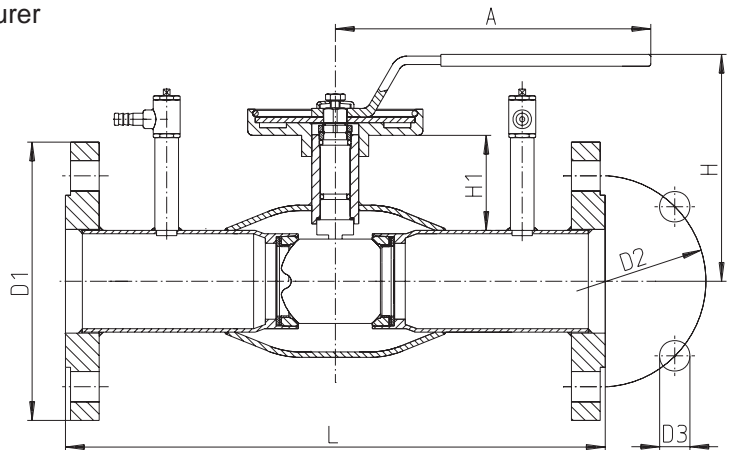
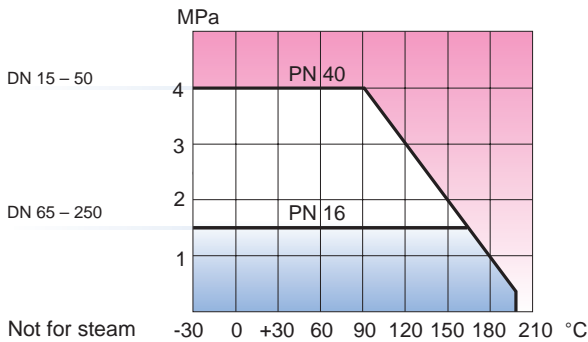

DN	PN body	PN flanges	Product No.	D1	D2	D3	H	H1	A	L	Holes	Weight
15	40	40	243 015	95	65	14	100	18	140	250	4	2,2
20	40	40	243 020	105	75	14	100	18	140	250	4	2,6
25	40	40	243 025	115	85	14	100	27	150	250	4	3,1
32	40	40	243 032	140	100	18	100	27	150	280	4	4,7
40	40	40	243 040	150	110	18	105	33	190	280	4	5,9
50	40	40	243 050	165	125	18	110	33	190	320	4	7,6
65	25	16	243 065	185	145	18	165	52	280	320	4	9,8
80	25	16	243 080	200	160	18	175	58	280	320	8	11,3
100	25	16	243 100	220	180	18	190	56	280	350	8	15,0
125	25	16	243 125	250	210	18	210	58	420	350	8	22,0
150	25	16	243 150	285	240	22	230	64	600	370	8	30,4
200	25	16	243 200	340	295	22	-	74	-	425	12	51,0
250	25	16	243 250	405	355	26	-	88	-	550	12	100,0