

DETAIL A

Pos	Part name	Material	QTY
1	Body	CF8M	1
2	End Cap	CF8M	2
3	Ball	CF8M	1
4	Seat Ring	CF8M	2
5	Seat	CTFE	2
6	Joint Gasket	Graphite	2
7	Thrust Washer	RTFE	1
8	Stem	SS316	1
9	Gland Packing	Graphite	1
9.1	Gland Packing	GLASS FIBER FILLED PTFE	1
10	Gland Bush	SS316	1
11	Stop Washer	SS316	1
12	Stem Nut	SS316	1
13	Handle - A	SS316	1
14	Handle - B	SS316	1
15	Handle Cover	VINYL	1
16	Bolt	SS316	6
17	Bolt Washer	SS316	12
18	Bolt Nut	SS316	12
19	Belleville Washer	SS301	2
20	Stop Pin	SS316	1
21	Handle Screw	SS316	2
22	O-Ring	VITON	1
23	Ant-Static Device	SS316	2

S600-1F DN65 - DN100

KV	Torque (RPTFE)
1728 m ³ /h	114 nm

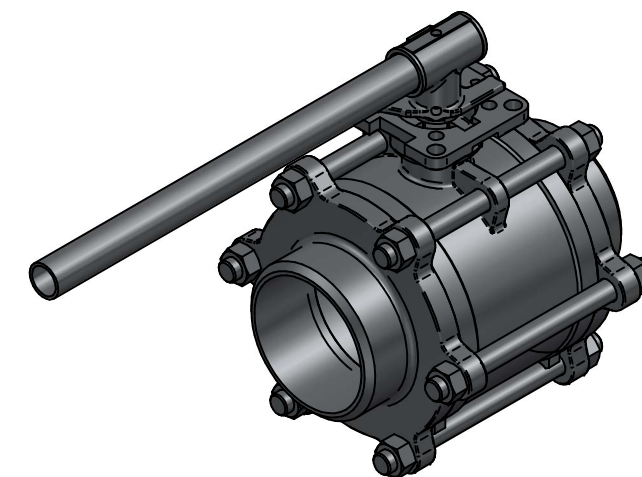

TITLE 3PC BALL VALVE S600-3F 1000PSI 4" WELDED
F-BORE FLOATING CF8M/CF8M/CTFE F07/10
SQR17 FIRESAFE ATEX-IIC W/HANDLE MAR88-3F

	NAME	DATE	SIZE	DWG NO
DRAWN	EMLA	23.01.2024	A3	TRW-100-S600-3F-100
CHECKED	EMLA	23.01.2024	FILE NAME: TRW-100-S600-3F-100.dft	
ENG APPR	TOCO	dd.mm.yyyy	SCALE: 1:5	REV: 00
MGR APPR	TOCO	dd.mm.yyyy	WEIGHT: 25.8 kg	SHEET: 1 OF 1

UNLESS OTHERWISE SPECIFIED
DIMENSIONS ARE IN MILLIMETERS
AND TOLERANCES ARE +/-0,5

REV	DESCRIPTION	DATE	APPROVED
00	ISSUED	07.02.2024	JOB
REVISION HISTORY			