

WELDING ENDS ACCORDING TO ISO 1127

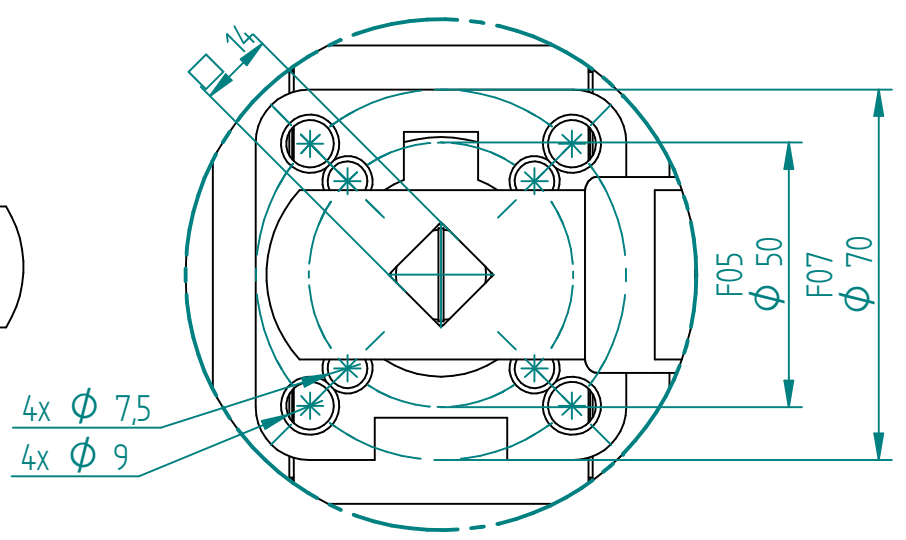
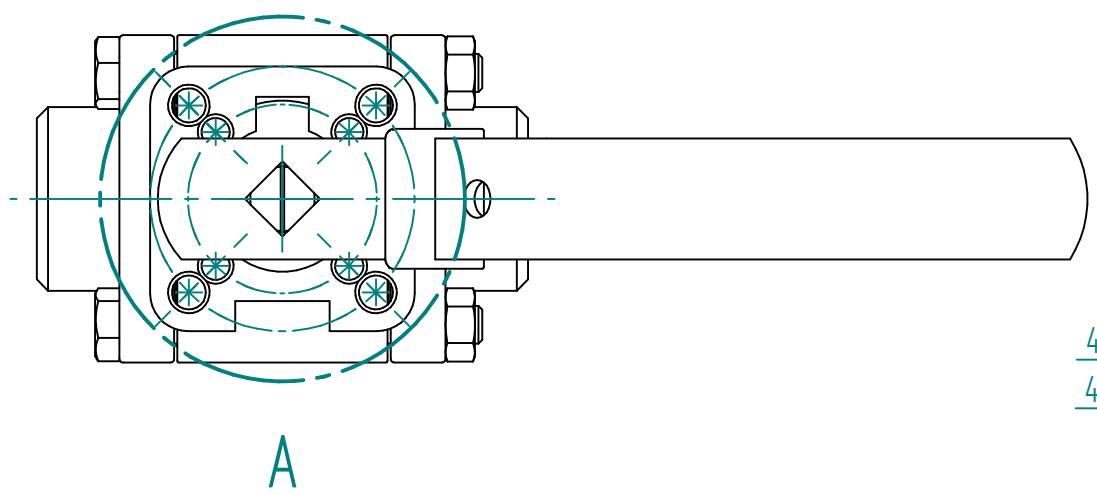

DETAIL A

Pos	Part name	Material	QTY
1	Body	CF8M	1
2	End Cap	CF8M	2
3	Ball	SS316*	1
4	Seat	CTFE	2
5	Joint Gasket	Graphite	2
6	Thrust Washer	RTFE	1
7	Stem	SS316	1
8	Gland Packing	Graphite	1
8.1	Gland Packing	GLASS FIBER FILLED PTFE	1
9	Gland Bush	SS316	1
10	Stop Washer	SS316	1
11	Stem Nut	SS316	2
12	Handle	SS316	1
13	Handle Cover	Vinyl	1
14	Stem Washer	SS316	1
15	Bolt	SS316	4
16	Bolt Nut	SS316	4
17	Bellville Washer	S301	2
18	Stop Pin	SS316	1
19	Pin Nut	SS316	1
20	Locking Device	SS316	1
21	O-Ring	VITON	1
22	Washer	SS316	1
23	Anti-static Device	SS316	1

S600-1F DN8 - DN50
 * 1/4", 3/8" ~ CF8M
 1/2", 3/4", 1", 1 1/4", 1 1/2", 2" ~ SS316

KV	Torque (RPTFE)
216 m ³ /h	33 nm

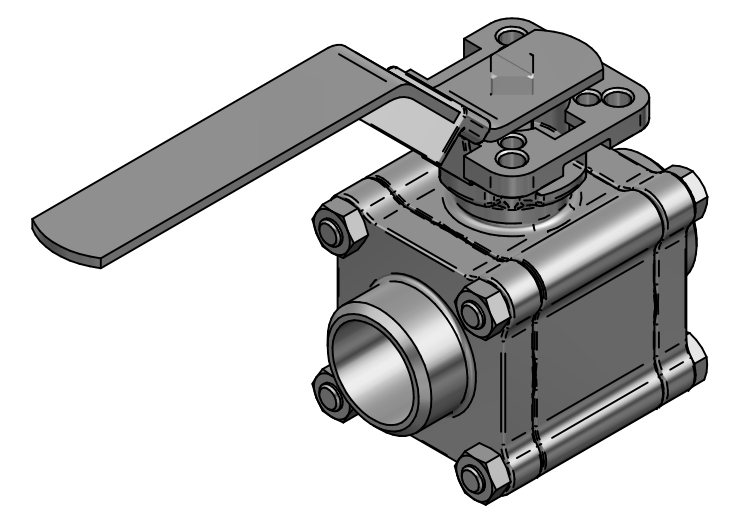

DRAWN	NAME	DATE	SIZE	DWG NO	UNLESS OTHERWISE SPECIFIED DIMENSIONS ARE IN MILLIMETERS AND TOLERANCES ARE +/-0,5
	EMLA	20.01.2024	A3	TRW-100-S600-3F-040	
CHECKED	EMLA	20.01.2024	FILE NAME: TRW-100-S600-3F-040.dft		
ENG APPR	TOCO	dd.mm.yyyy	SCALE: 1:2	REV: 00	
MGR APPR	TOCO	dd.mm.yyyy	WEIGHT: 4.21 kg	SHEET: 1 OF 1	

TITLE 3PC BALL VALVE S600-3F 1500PSI 1 1/2" WELDED F-BORE FLOATING CF8M/CF8M/CTFE F05/07 SQR14 FIRESAFE ATEX-IIC W/HANDLE MAR88-3F

REV	DESCRIPTION	DATE	APPROVED
00	ISSUED	07.02.2024	JOB
REVISION HISTORY			