

DETAIL A

Pos	Part name	Material	QTY
1	Body	1.4408	1
2	End Cap	1.4408	1
3	Ball	1.4408	1
4	Seat	TFM1600	2
5	Joint Gasket	SS316 with Graphite	1
6	Stem	SS316	1
7	Thrust Washer	RTFE	1
8	Gland Packing	Graphite	1
9	Gland Packing	Glass Fiber Filled PTFE	1
10	Gland Bush	SS316	1
11	Belleville Washer	SS301	2
12	Stop Washer	SS316	1
13	Stem Nut	SS316	1
14	O-Ring	VITON	1
15	Handle Screw	SS316	2
16	Handle-A	SS316	1
17	Handle-B	SS316	1
18	Handle Cover	Vinyl	1
19	Bolt	SS316	10
20	Bolt Nut	SS316	10
21	Stop Pin	SS316	1
22	Anti-Static Device	SS316	2

F502-6F DN80 - DN150

KV	Torque (RPTFE)
4590 m <sup>3</sup> /h	247 nm

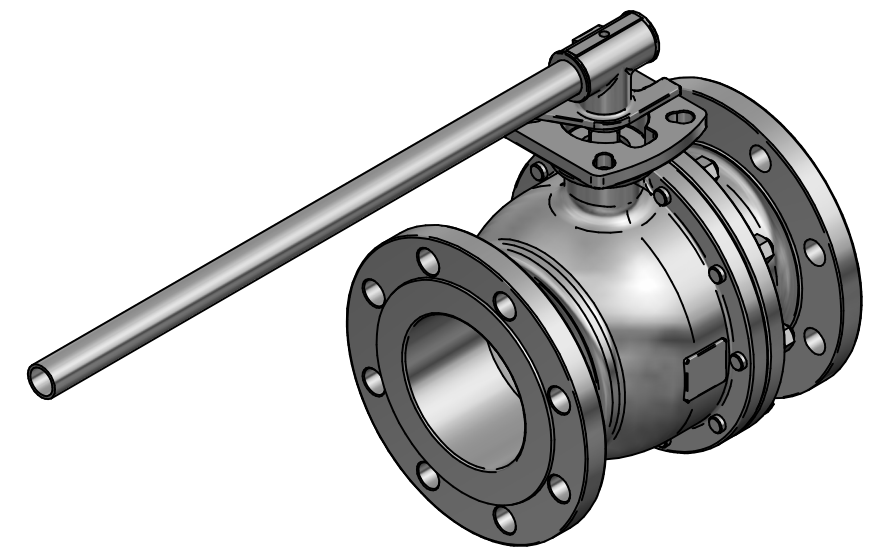

DRAWN	NAME	DATE	SIZE	DWG NO
	EMLA	25.02.2024	A3	TRW-100-F502-6F-150
CHECKED	EMLA	25.02.2024	FILE NAME: TRW-100-F502-6F-150.dft	
ENG APPR	TOCO	dd.mm.yyyy	SCALE: 1:5	REV: 00
MGR APPR	TOCO	dd.mm.yyyy	WEIGHT: 79.31 kg	SHEET: 1 OF 1

UNLESS OTHERWISE SPECIFIED DIMENSIONS ARE IN MILLIMETERS AND TOLERANCES ARE +/-0,5

REV	DESCRIPTION	DATE	APPROVED
00	ISSUED	07.02.2024	JOB
REVISION HISTORY			

TITLE 2PC BALL VALVE F502-6F PN40 DN150 FLANGED F-BORE FLOATING CF8M/CF8M/TFM F12/F14 SQ27 FIRESAFE DESIGN ATEX-IIC W/HANDLE MAR90D-6F