

| Pos | Part name | Material | QTY |
|-----|--------------------|-------------------------|-----|
| 1 | Body | 1.4408 | 1 |
| 2 | End Cap | 1.4408 | 1 |
| 3 | Ball | SS316 * | 1 |
| 4 | Seat | TFM1600 | 2 |
| 5 | Joint Gasket | SS316 with Graphite | 1 |
| 6 | Stem | SS316 | 1 |
| 7 | Thrust Washer | RTFE | 1 |
| 8 | Gland Packing | Graphite | 1 |
| 9 | Gland Packing | Glass Fiber Filled PTFE | 1 |
| 10 | Gland Bush | SS316 | 1 |
| 11 | Belleville Washer | SS301 | 2 |
| 12 | Stop Washer | SS316 | 1 |
| 13 | Stem Nut | SS316 | 2 |
| 14 | Stem Washer | SS316 | 1 |
| 15 | Handle | SS316 | 1 |
| 16 | Handle Cover | Vinyl | 1 |
| 17 | Bolt | SS316 | 4 |
| 18 | Bolt nut | SS316 | 4 |
| 19 | Stop Pin | SS316 | 1 |
| 20 | Pin Nut | SS316 | 1 |
| 21 | Locking Device | SS316 | 1 |
| 22 | O-Ring | Viton | 1 |
| 23 | Washer | SS316 | 1 |
| 24 | Anti-Static Device | SS316 | 2 |

F502-6F DN15 - DN65
 * 3/4", 1-1/2", 2" ~ SS316
 1/2", 1", 1-1/4", 2-1/2" ~ 1.4408

| KV | Torque (RPTFE) |
|-----------------------|----------------|
| 366 m ³ /h | 39 nm |

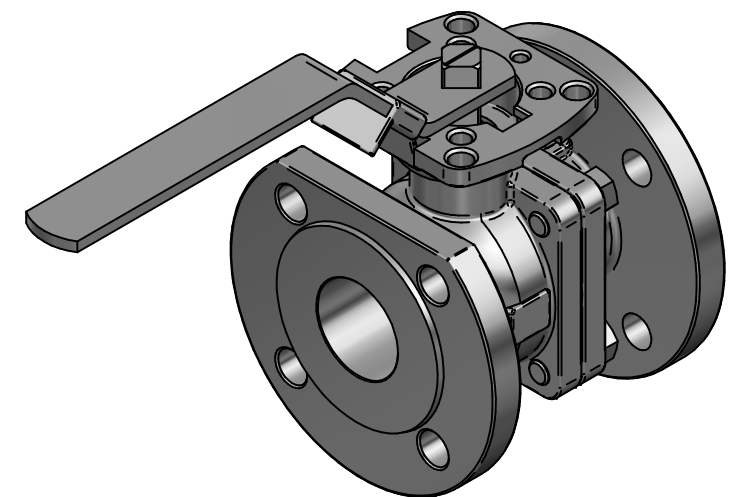

TITLE 2PC BALL VALVE F502-6F PN40 DN50 FLANGED
 F-BORE FLOATING CF8M/CF8M/TFM F07/F10
 SQ17 FIRESAFE ATEX-IIC W/HANDLE MAR90D-6F

| | NAME | DATE | SIZE | DWG NO |
|----------|------|------------|------------------------------------|---------------------|
| DRAWN | EMLA | 25.02.2024 | A3 | TRW-100-F502-6F-050 |
| CHECKED | EMLA | 25.02.2024 | FILE NAME: TRW-100-F502-6F-050.dft | |
| ENG APPR | TOCO | dd.mm.yyyy | SCALE: 1:2 | REV: 00 |
| MGR APPR | TOCO | dd.mm.yyyy | WEIGHT: 10.16 kg | SHEET: 1 OF 1 |

UNLESS OTHERWISE SPECIFIED
 DIMENSIONS ARE IN MILLIMETERS
 AND TOLERANCES ARE +/-0,5

| REV | DESCRIPTION | DATE | APPROVED |
|------------------|-------------|------------|----------|
| 00 | ISSUED | 07.02.2024 | JOB |
| REVISION HISTORY | | | |