

Pos	Part name	Material	QTY
1	Body	1.4408	1
2	End Cap	1.4408	1
3	Ball	1.4408 *	1
4	Seat	TFM1600	2
5	Joint Gasket	SS316 with Graphite	1
6	Stem	SS316	1
7	Thrust Washer	RTFE	1
8	Gland Packing	Graphite	1
9	Gland Packing	Glass Fiber Filled PTFE	1
10	Gland Bush	SS316	1
11	Belleville Washer	SS301	2
12	Stop Washer	SS316	1
13	Stem Nut	SS316	2
14	Stem Washer	SS316	1
15	Handle	SS316	1
16	Handle Cover	Vinyl	1
17	Bolt	SS316	4
18	Bolt nut	SS316	4
19	Stop Pin	SS316	1
20	Pin Nut	SS316	1
21	Locking Device	SS316	1
22	O-Ring	Viton	1
23	Washer	SS316	1
24	Anti-Static Device	SS316	2

F502-6F DN15 - DN65
 * 3/4", 1-1/2", 2" ~ SS316
 1/2", 1", 1-1/4", 2-1/2" ~ 1.4408

KV	Torque (RPTFE)
94 m ³ /h	23 nm

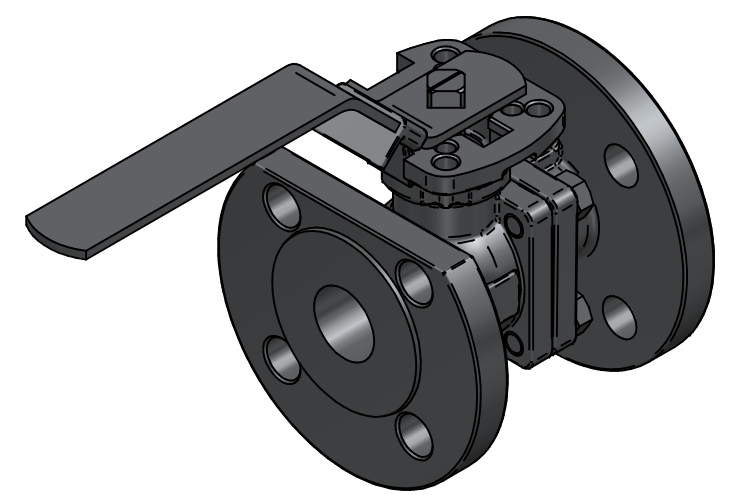

DRAWN	NAME	DATE	SIZE	DWG NO
	EMLA	09.02.2024	A3	TRW-100-F502-6F-032
CHECKED	EMLA	09.02.2024	FILE NAME: TRW-100-F502-6F-032.dft	
ENG APPR	TOCO	dd.mm.yyyy	SCALE: 1:2	REV: 00
MGR APPR	TOCO	dd.mm.yyyy	WEIGHT: 5.78 kg	SHEET: 1 OF 1

UNLESS OTHERWISE SPECIFIED DIMENSIONS ARE IN MILLIMETERS AND TOLERANCES ARE +/-0,5

REV	DESCRIPTION	DATE	APPROVED
00	ISSUED	07.02.2024	JOBE
REVISION HISTORY			

TITLE 2PC BALL VALVE F502-6F PN40 DN32 FLANGED F-BORE FLOATING CF8M/CF8M/TFM F05/F07 SQ14 FIRESAFE ATEX-IIC W/HANDLE MAR90D-6F