

DETAIL A

| Pos | Part name | Material | QTY |
|-----|----------------------|-------------------------|-----|
| 1 | Body | 1.4408 | 1 |
| 2 | End Cap | 1.4408 | 1 |
| 3 | Ball | 1.4408 | 1 |
| 4 | Seat | TFM1600 | 2 |
| 5 | Joint Gasket | SS316 with Graphite | 1 |
| 6 | Stem | SS316 | 1 |
| 7 | Thrust Washer | RTFE | 1 |
| 8 | O-Ring | VITON | 1 |
| 9 | Gland Packing | Graphite | 2 |
| 9.1 | Gland Packing | GLASS FIBER FILLES PTFE | 1 |
| 10 | Gland | CF8M | 1 |
| 11 | Gear Box | Ductile Iron | 1 |
| 12 | Handle | Ductile Iron | 1 |
| 13 | Bolt | SS316 | 12 |
| 14 | Bolt Nut | SS316 | 12 |
| 15 | Gland Bolt | SS316 | 2 |
| 16 | Bolt Washer | SS316 | 2 |
| 17 | Bolt Nut | SS316 | 2 |
| 18 | Anti - Static Device | SS316 | 2 |

| KV | Torque (RPTFE) |
|------------------------|----------------|
| 8330 m ³ /h | 819 nm |

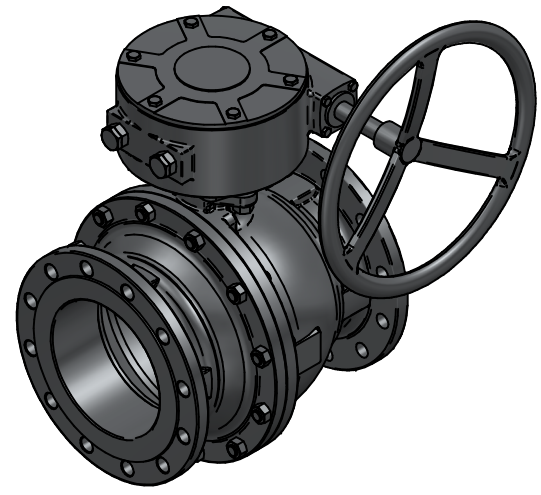

| | | | | | |
|---|-------------------------|---------------------------|---|--------------------------------------|--|
| TITLE 2PC BALL VALVE F502-4F PN16 DN200 FLANGED F-BORE FLOATING CF8M/CF8M/TFM F14/F16 SQ36 FIRESAFE DESIGN ATEX-IIC W/GEAR MAR90D-4F | NAME EMLA | DATE 26.03.2024 | SIZE A3 | DWG NO TRW-100-F502-4F-200 | UNLESS OTHERWISE SPECIFIED DIMENSIONS ARE IN MILLIMETERS AND TOLERANCES ARE +/-0,5 |
| | CHECKED EMLA | 26.03.2024 | FILE NAME: TRW-100-F502-4F-200.dft | | |
| | ENG APPR TOCO | dd.mm.yyyy | SCALE: 1:10 | REV: 00 | |
| | MGR APPR TOCO | dd.mm.yyyy | WEIGHT: | SHEET: 1 OF 1 | |

| REV | DESCRIPTION | DATE | APPROVED |
|------------------|-------------|------------|----------|
| 00 | ISSUED | 07.02.2024 | JOB |
| REVISION HISTORY | | | |