

Rep.	DESIGNATION
1	CORPS/BODY
2	SIEGE/SEAT
3	RESSORT/SPRING
4	PISTON/PISTON
5	JOINT DE CHAPEAU/BONNET GASKET
6	CHAPEAU/BONNET
9	PLAQUE D'IDENTIFICATION/NAME PLATE
10	VIS DE CHAPEAU/BONNET SCREW

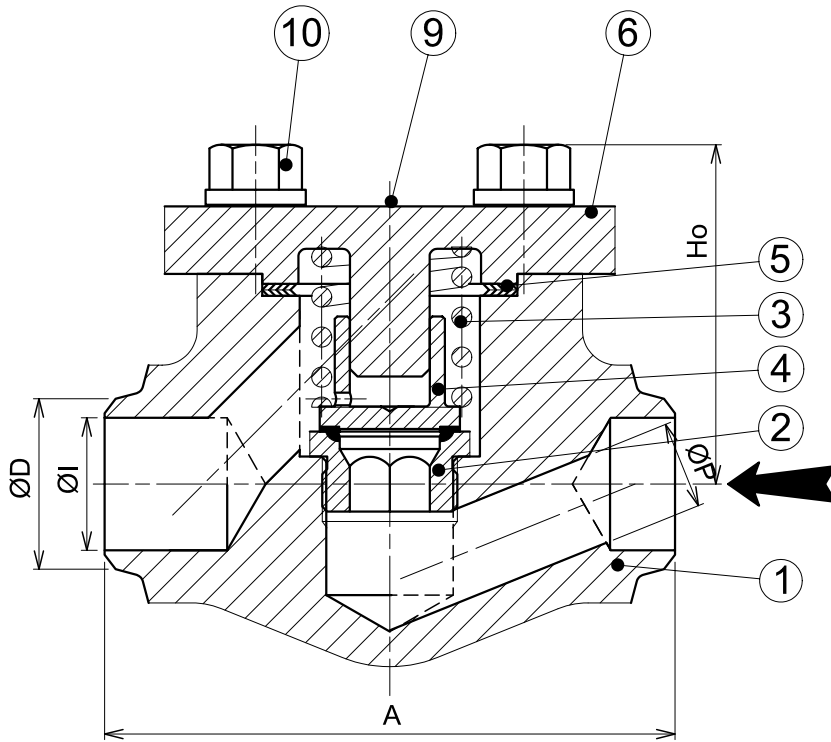

BUTT WELD END SUIVANT/ acc. to ANSI B16-25

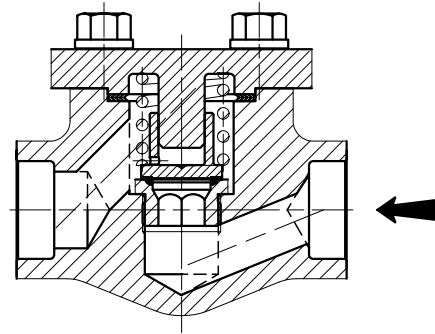

SOCKET WELD END SUIVANT/ acc. to ANSI B16-11

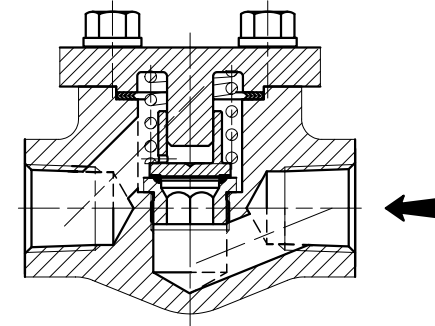

NPT SUIVANT/ acc. to ANSI B1.20.1

Matériel conforme à NF M87.412- BS5352  
 Matériel in acc. with BS 5352 - NF M87.412



CS 3422  
 112,114 avenue de Vendôme  
 41034 BLOIS Cedex  
 FRANCE

CLAPET A PISTON HORIZONTALE - BW NPT SW  
 PISTON CHECK VALVE HORIZONTAL TYPE - BW NPT SW

Sie 800 -1500 -2500

Class 800 - 1500 -2500

CHAPEAU BOULONNE / SIEGE VISSE  
 BOLTED BONNET / RENEWABLE SEAT