

SIZE	d	L	H	D	F	A	B	C	N	M	E	G	W (kgf/cm)
1/4"	11	69.3	58	132	34.7	10.35	5.35	9	4	M5*0.8	42	12	33
3/8"	11	69.3	58	132	34.7	10.35	5.35	9	4	M5*0.8	42	12	33
1/2"	12.5	75.7	61	132	38.3	10.35	5.35	9	4	M5*0.8	42	12	33
3/4"	16	86.6	82	180	44.7	13.85	6.85	11	4	M6*1.0	50	15	50
1"	20	103	87.5	180	50.8	20	8.5	11	4	M6*1.0	50	15	90
1 1/4"	25	118.2	93	180	57.7	19.35	7.85	11	4	M6*1.0	50	15	170
1 1/2"	32	125.8	104	210	62.6	25.75	10.25	11	4	M8*1.25	70	15	220
2"	38	149	112	225	74.3	25.25	9.75	14	4	M8*1.25	70	18.5	380

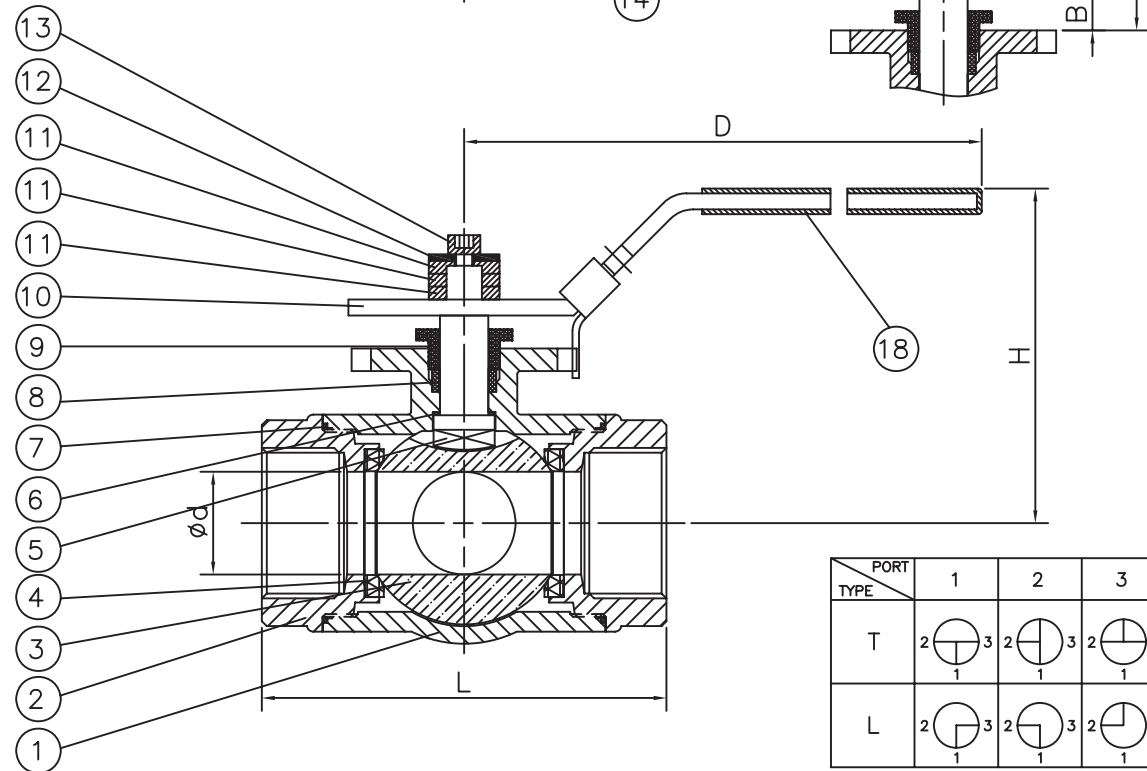

PORT TYPE	1	2	3	4
T				
L				

NO	DRAW NO	PART NAME	MATERIAL	QTY
1	01	BODY	ASTM A351 Gr.CF8M/WCB	1
2	02	CAP	ASTM A351 Gr.CF8M/WCB	2
3	03	BALL	ASTM A351 Gr.CF8M	1
4	04	BALL SEATS	PTFE	1 SETS
5	05	STEM	S.S.316	1
6	06	THRUST WASHER	PTFE	1
7	07	END SEALS	PTFE	2
8	08	STEM PACKING	PTFE	1 SETS
9	09	GLAND	S.S.304	1
10	10	HANDLE	S.S.304	1
11	11	WASHER	S.S.304	1~4
12	12	WASHER	S.S.304	1
13	13	HANDLE NUT	S.S.304	1
14	14	CAP	ASTM A351 Gr.CF8M/WCB	1
15	15	END SEALS	PTFE	1
16	16	STOPPER	S.S.304	1
17	17	SCREW	S.S.304	1
18	18	HANDLE SLEEVE	VINYL GRIP	1



TEL : 886-2-23948307  
FAX : 886-2-23948309  
Right Hand Enterprise Corp

501~1000	0.5
101~500	0.2
21~100	0.2
1~20	0.1
TOLERANCE	

ISSUE DATE	2008.11.25
APPROVE BY	JEFF YU
DRAWING BY	ERIA CHEN

MATERIAL	AS TABLE
SCALE	
UNIT	mm

3-WAY BALL VALVE	
ITEM NO.	JV-94
DRAWING NO.	1-940000-01