

Product overview

- Rated voltage: AC230V,AC110V,AC24V
- Rated torque: 110N.m[132N.m@Max]
- Running time: **about 20s**
- Install valves: 2-way, 3-way ball valve and butterfly valve
- Wiring and feedback model: B3S,BD3S,B3C,BD3C
- Adopted high-performance Synchronous Motor
- It can be used 20,000 times.*1
- ✘ It is forbidden to use 2 or more actuators in parallel



Technical Data

Electrical data	Rated voltage	AC230V 50/60HZ	AC110V 50/60HZ	AC24V 50/60HZ
	Rated voltage range	AC190-250V	AC90-130V	AC22-28V
	Power consumption	13.2W@running0.0W@holding	15W@running0.0W@holding	10.8W@running0.0W@holding
	Peak current	300mA@5ms	600mA@5ms	2.5A@5ms
	Fuse	2A	3A	5A
Functional data	Connecting cable	Connector:9P-5.08-500V × (0.5-1.5)mm ²		
	Rated torque	110Nm@rated voltage		
	Angle of rotation	90±2°		
	Max angle of rotation	360°		
	Manual operation	✘ Matching hexagon wrench, using at no power		
	Running time	About 20s (per 90°)		
	Operating frequency	Not continuous operation operating cycle ≥1min		
Working conditions	Sound power level	Max65dB(A)		
	Position indicator	Mechanical		
	Electricity safety level	I Type(ground protection)	I Type(ground protection)	III Type(safty low voltage)
	Inflaming retarding level	1.6mmHB/ UL94 test method		
	Enclosure	IP67 As Per En60529/GB4208-2008 (all directions)		
		F type can add bracket or dehumidifying heater		
	Insulation resistance	100MΩ/1500VDC	100MΩ/1500VDC	100MΩ/500VDC
	Withstand voltage	1500VAC@1Min	1500VAC@1Min	500VAC@1Min
	Medium temperature	≤ 80° can install to actuator directly		
		✘ > 80° need to install bracket or heat radiation stand		
	Working environment	✘ Indoor or outdoor; if exposed to the rain or sunshine, need to install protective device for the actuator		
	Explosion-proof level	⚠ Not explosion proof products, do not use them in flammable and explosive environment		
	Ambient temp	-20℃ — 60℃		
	Non-operation temp	≤ -40℃ or ≥ 80℃		
	Ambient humidity	5-95%RH non-condensing		
	Shock resistance	≤ 300m/s ²		
	Vibration	✘ 10 to 55 Hz, 1.5 mm double amplitude		
Installation notes	360°any angle, need manual operation or allow for wiring space			
Maintenance	Free maintenance			
Dimensions / weight	Certification	CE		
	Dimensions (LXWXH)	See "Dimensions"		
	Connection standard	ISO5211 F05、 F07		
	Output axis specification	Female octagonal		
	Hole deepness	≤ 20mm(Female octagonal)		
	Weight	ABS material 2.2kg		

*1 Test condition:Rated load,test at under 25℃ working temperature and 50% humidity,lead the result from 2 times switching cycle,which will be influenced by different load and working environment.

Dimension 【Female octagonal】

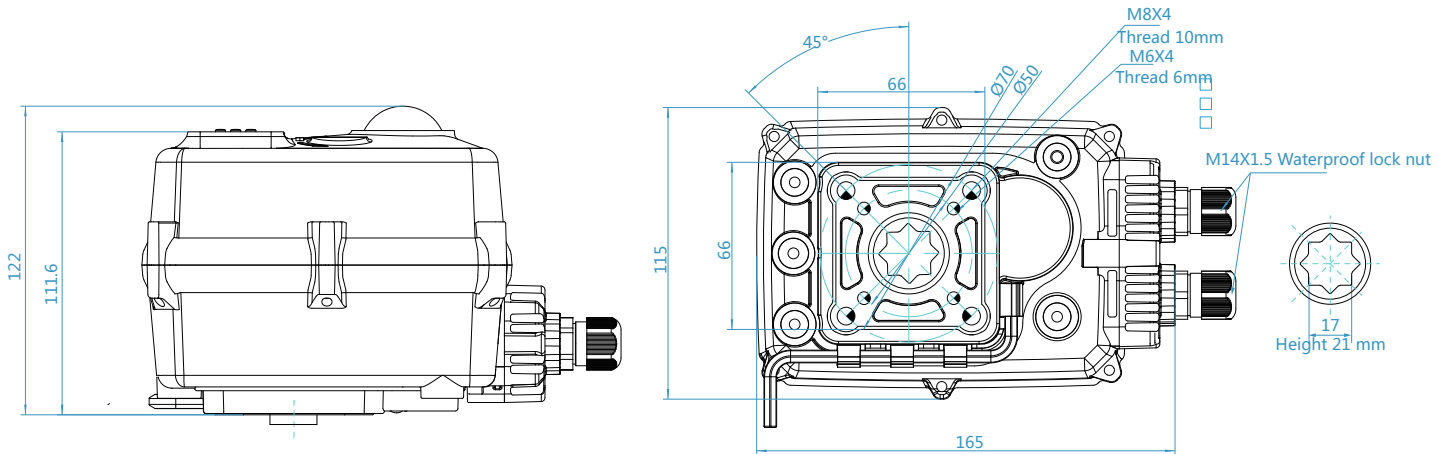

Main parts

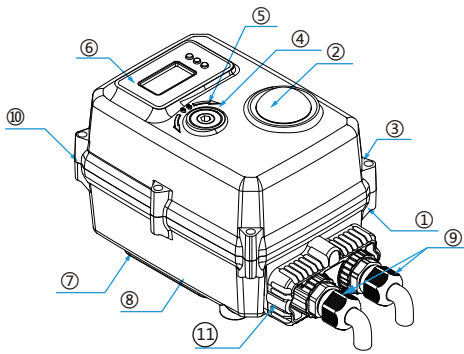

Parts	Material	Parts	Material
1 Actuator	ABS	8 Hexagon wrench	Tool steel
2 Indicator	TransparentAS	9 Waterproof cable connector	NiLon
3 Screwx4	304	10 seal part between up and down cover	NBR
4 Manual shaft	304	11 Terminal cover	ABS
5 Oil seal	NBR		
6 Label	PVC		
7 Wrench fixed	ABS		

Wiring diagrams

B3S

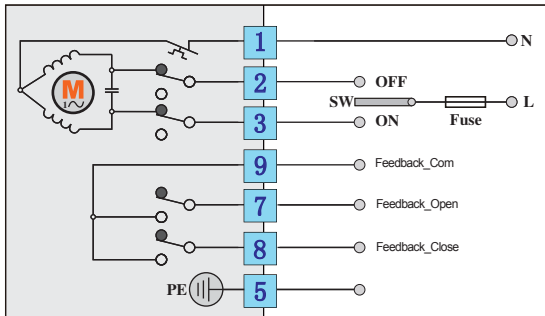

Control instructions:

- SW is connected with [2], the actuator will rotate clockwise ↻. When the valve is closed, [9] is connect with [8], giving signal of closing.
- SW is connected with [3], the actuator will rotate anticlockwise ↻. When the valve is open, [9] is connect with [7], giving signal of opening.
- ※ Notice 1: [9] is not connected with [7] and [8], when the actuator is running.
- ※ Notice 2: The feedback signal is a little earlier than the actual position, so please do not cut power immediately, when you get the feedback signal.

BD3S

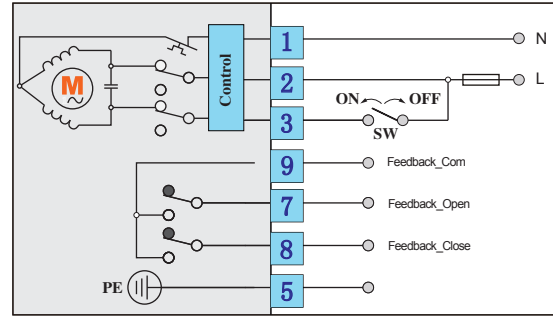

Control instructions:

- If SW is disconnected; the actuator will drive valve close clockwise ↻. When the valve is closed completely, [9] is connected with [8], giving signal of closing.
- If SW is connected, the actuator will drive valve open anticlockwise ↻. When the valve is open completely, [9] is connected with [7], giving signal of opening.
- ※ Notice 1: [9] is not connected with [8] [7], when the actuator is running.
- ※ Notice 2: The feedback signal is a little earlier than the actual position, so please do not cut power immediately, when you get the feedback signal.

B3C

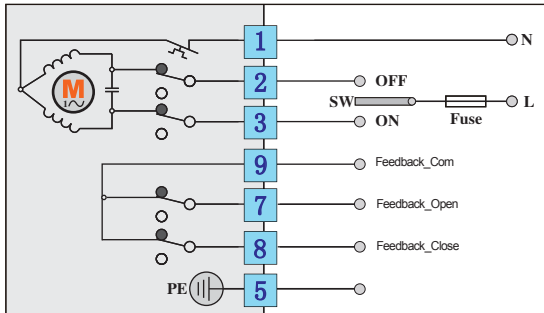

Control instructions:

- SW is connected with [2], the actuator will rotate clockwise ↻. When the valve is closed, [9] is non-connect with [8], giving signal of closing.
- SW is connected with [3], the actuator will rotate anticlockwise ↻. When the valve is open, [9] is non-connect with [7], giving signal of opening.
- ※ Notice 1: [9] is connected with [7] and [8], when the actuator is running.
- ※ Notice 2: The feedback signal is a little earlier than the actual position, so please do not cut power immediately, when you get the feedback signal.

BD3C

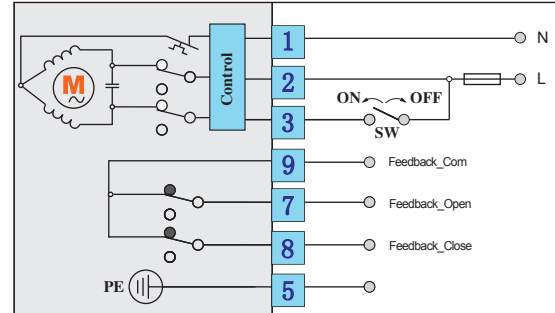

Control instructions:

- If SW is disconnected; the actuator will drive valve close clockwise ↻. When the valve is closed completely, [9] is non-connected with [8], giving signal of closing.
- If SW is connected, the actuator will drive valve open anticlockwise ↻. When the valve is open completely, [9] is non-connected with [7], giving signal of opening.
- ※ Notice 1: [9] is connected with [8] [7], when the actuator is running.
- ※ Notice 2: The feedback signal is a little earlier than the actual position, so please do not cut power immediately, when you get the feedback signal.

9P-5.08 Terminal diagram

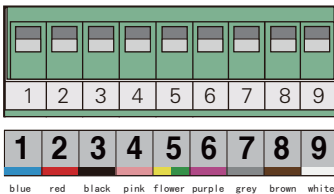

Wiring instructions:

1. Fuse: please refer to manual for more parameters.
2. SW switching capability: please refer to manual for more parameters.
3. Feedback signal contact load capacity: 0.1A/250VAC 0.5A/30VDC.
4. Please make sure actuator connect ground reliably.

Anti-condensation heater **【Accessory】**

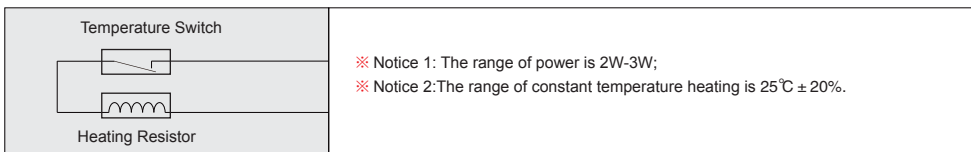

- ※ Notice 1: The range of power is 2W-3W;
- ※ Notice 2: The range of constant temperature heating is 25°C ± 20%.

Wire notice

❌ Error wiring

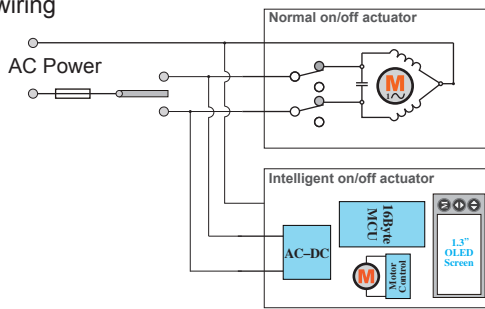

✅ Right wiring

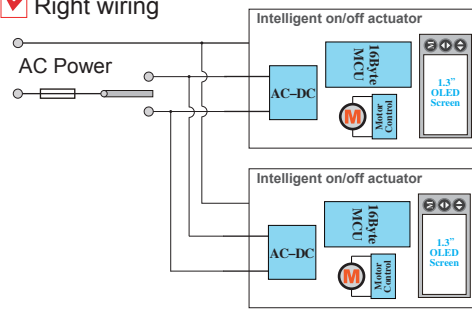

※Note:Don't use in paralle with Normal on/off actuator under control of the same contactor.

Mounting instructions

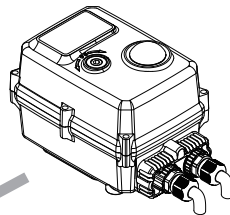

Notice:

- ※1.When assembly with valve,it's suggest to use spring washer add flat washer in order to fasten the screw and nut.
- ※2.It's recommend to use 704 silica gel or instant cement instead of anaerobic adhesive and UV glue.
- ※3.Pls keep the actuator housing away from organic solvents,such as: kerosene,butanone ,tetrachlormethane etc.,or the housing will crack.

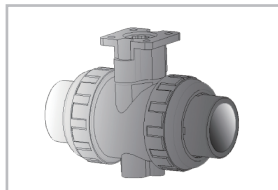

Diagram1(With bracket)

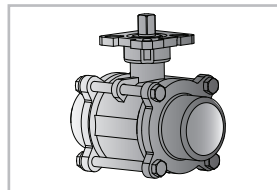

Diagram2(Direct mount)

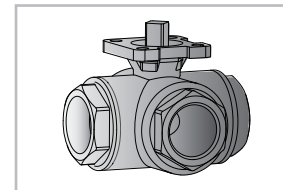

Diagram3(Direct mount)

Diagram1 UPVC plastic ball valve+bracket assembly,Diagram2 3piece stainless steel ball valve assembly
Diagram3 3piece stainless steel 3way ball valve assembly

Installed valve technical requirements

Valve type	Recommend install condition
wafer butterfly valve	actuator rate torque ≥ 2 times valve max torque
flange butterfly valve	actuator rate torque ≥ 1.7 times valve max torque
metal ball valve	actuator rate torque ≥ 1.7 times valve max torque
plastic ball valve	actuator rate torque ≥ 1.5 times valve max torque

- 1. If the ball valve is out of operation for a long time, and the torque value of first on or off is the max torque
- 2. When installing direct mount model valve, the hole deep ≤ 20 mm. It requires cutting if the output shaft is longer than 20mm.
- 3. Pls pay attention to the following items if you install the bracket and coupling by yourself:
 - ※ The intensity of bracket should meet the using requirements: the bracket twisting extent ≤ 0.2 mm in the process of on or off.
 - ※ The parallelism of bracket ≤ 0.5 mm.
 - ※ When processing the shaft hole at both end of the coupling, it is necessary to ensure the accuracy and concentricity. The purpose is to make sure the mechanical hysteresis $\leq 10^\circ$, otherwise it will cause the actuator unable to work.
- 4. Screw should be installed spring washer、flat washer, and we suggest you daub some glue cement around the screw in case of screw loosening.
- 5. After installation, user should switch the valve on and off one time with handle device first. Modifying the valve after make sure it works well.

Adjusting valve location instructions

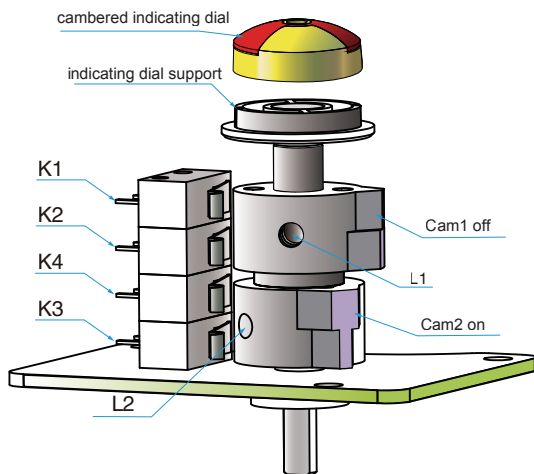

Diagram 1

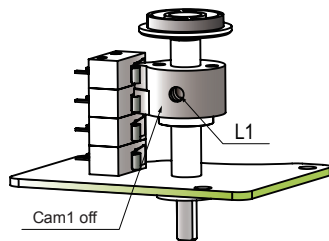

Diagram 3

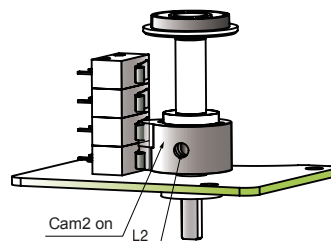

Diagram 4

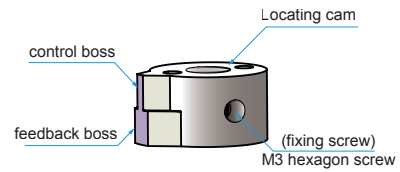

Diagram 2

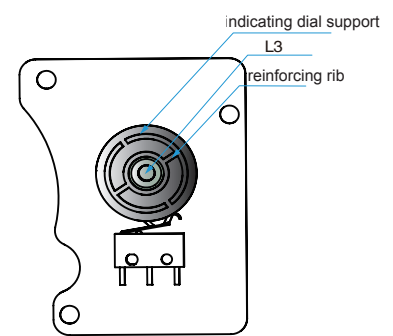

Diagram 5

Diagram 1 locating mechanism structural schematic diagram

Diagram 3 close adjustment schematic diagram

Diagram 5 Indicating dial adjustment schematic diagram

Diagram 2 locating cams structural schematic diagram

Diagram 4 open adjustment schematic diagram

Valve position adjustment

※ Notice 1: The default is that rotating in clockwise direction means closing ,and rotating in anticlockwise direction means opening.

※ Notice 2: B3P does not have K2,K4 micro switch.

Micro-adjustment of electrical limit:

□1 Adjusting full close:

△ Rotate the valve to full close position with handle.

※ Since the valve has gone through “factory default setting”, this step can be omitted if the adjustment is slight.

△ Detach cambered indicating dial, loosen fixing screw L3 of indicating dial support, turn reinforcing rib as shown in diagram 5, perpendicular to the flow direction of valve, then screw up L3 and buckle up cambered indicating dial.

※ Caution: When screwing up L3, the torque ≤ 0.5 NM, otherwise it will damage locating driving gear.

△ Loosen fixing screw L1 of cam 1, drive cam 1 to rotate clockwise and trigger micro switches K2, K1 to move in turn and make sound. When K1 moves and makes sound, stop adjustment. Then screw up fixing screw L1.

□2 Adjusting full open:

△ Rotate the valve to full open position with handle;

△ loosen fixing screw L2 of cam2, drive cam 2 to rotate anticlockwise and trigger micro switches K4, K3 to move in turn and make sound. When K3 moves and makes sound, stop adjustment. Then screw up fixing screw L2.

□3 Wiring:

After modifying, connect the circuit according to the wiring label on the box cover. After confirmation, you can do power test.

□4 Power test:

△ mainly check the consistence of on and off between the actuator and the valve body. At the same time, please check whether the valve is full close or not. Special testing device is recommended.

※ In the process of adjustment, do not over tighten screws, otherwise it will damage screw threads or other parts.

Common failures and processing methods

	Fault phenomenon	Fault cause	Processing methods
□1	Actuator no action	△1 power not connected	Connect power
		△2 voltage below level or incorrect	Check whether voltage is within the normal range
		△3 overtemperature protection of motor	Check whether valve gets stuck or torque value is too big
		△4 terminal loose or poor contact	Check and correctly connect terminal
		△5 starting capacitance poor run	Contact the manufacturer to get repair
□2	No feedback signal	△1 line barrier of user acquisition signal	Connect user acquisition signal
		△2 microswitch damage	Change microswitch
□3	Actuator not fully closed	△1 use feedback signal to control actuator	Receive feedback signal doesn't mean actuator is fully closed, so don't cut power off
		△2 technical hysteresis increases due to abrasion between actuator and valve rod	1 Readjust valve-off position 2 Contact the manufacturer to get repair
□4	Actuator interior water ingress	△1 OD of incoming line cable non-standard	Contact the manufacturer to get repair
		△2 waterproof treatment of incoming line incomplete	
		△3 actuator lens wearout	
		△4 screws on connection cover/head cover /slide cover loose	

Working environment

- Indoor and outdoor are both optional.
- Not explosion proof products, ⚠ do not use them in flammable and explosive environment.
- You need to install protective device for the actuator if it is exposed to the rain or sunshine.
- Please pay attention to the ambient temp.
- When installing, you need to consider the reserved space for wiring and repairing.
- When power on, ⚠ it is not allowed to dismantle actuator and valve.
- When power on, ⚠ it is not allowed to do wiring.
- ✖ Absolutely no falling down the ground, which will hit the device and lead to improper operation.
- ✖ Absolutely no standing on the device, which will cause device malfunction or personal accident.
- ✖ It is forbidden to do wiring project in rainy day or when there is water splash.

Safety notice

- In order to use the device safely for a long term, please pre-read the manual carefully to ensure correct use.
- Notice item: Please understand the product specification and using method clearly to prevent personal safety danger or device damage.
- In order to indicate damage and danger, here we classify them as "warning ⚠" and "notice ✖".
- Both of contents are very important, which should be obeyed strictly.
 - "Warning ⚠": It will cause death or serious injury if not obeyed.
 - "Notice ✖": It will cause slight injury or device damage if not obeyed.
- Subject to technical changes.