

POS	Item Number	Description
1	Housing	GG25
2	Worm gear	GGG40
3	Worm	C.S(45#)
4	Worm shaft	SS316
5	Bolt, Zerk, Indicator	SS316

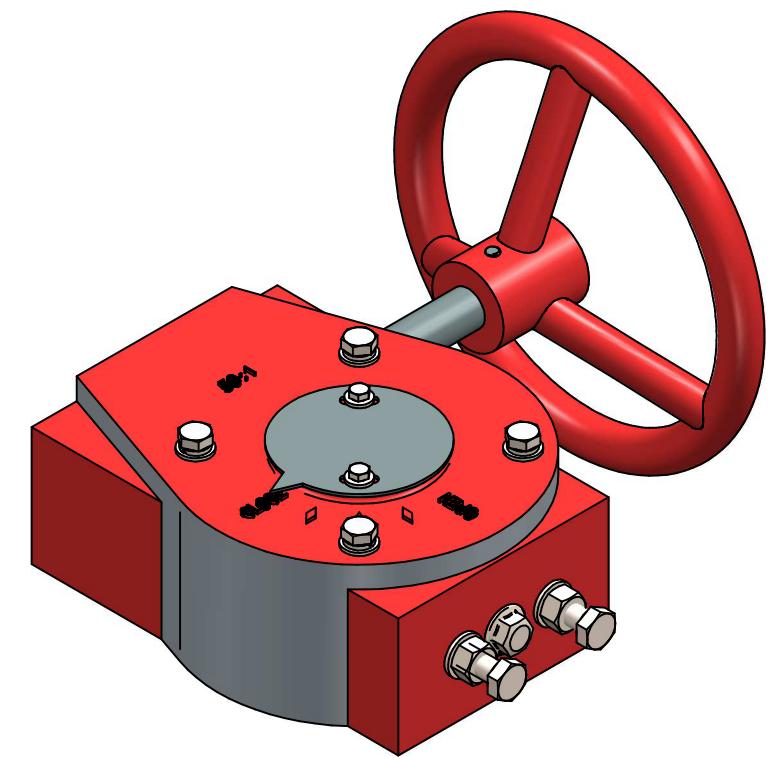
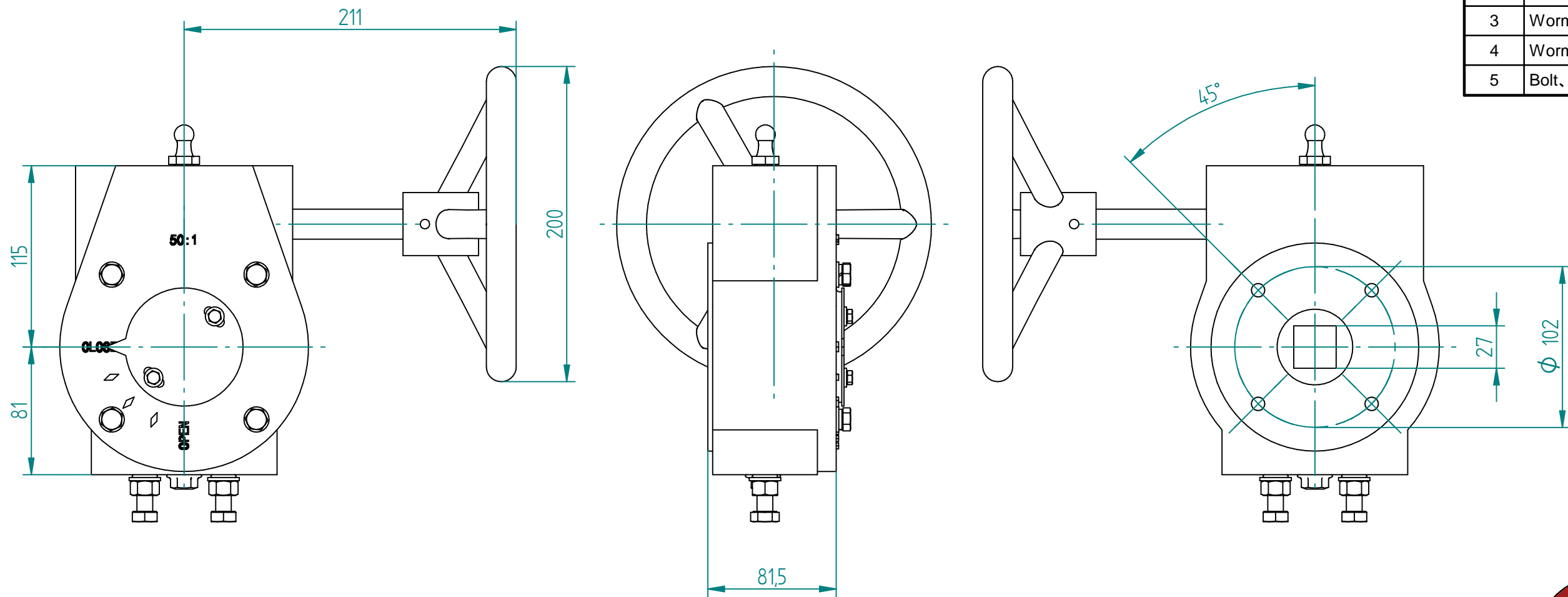

		NAME	DATE	SIZE	DWG NO
DRAWN		MOTO	20.04.2018	A3	DN300-350-WLT-01
CHECKED		TOCO	20.04.2018	FILE NAME: QIF WORM GEAR DN300-DN350 SQR 27.dft	
ENG APPR		TOCO	20.04.2018	SCALE: 1:3	REV:
MGR APPR		TOCO	20.04.2018	WEIGHT:	SHEET: 1 OF 1

UNLESS OTHERWISE SPECIFIED DIMENSIONS ARE IN MILLIMETERS AND TOLERANCES ARE +/-0,5

REV	DESCRIPTION	DATE	APPROVED
REVISION HISTORY			

TITLE QIF WORM GEAR DN300-DN350 / SQR 27