

No.	Part Name	Material
1	Body	GGG40
2	Disc	DI+Nylon11
3	Shaft	SS416
4	Seat	EPDM

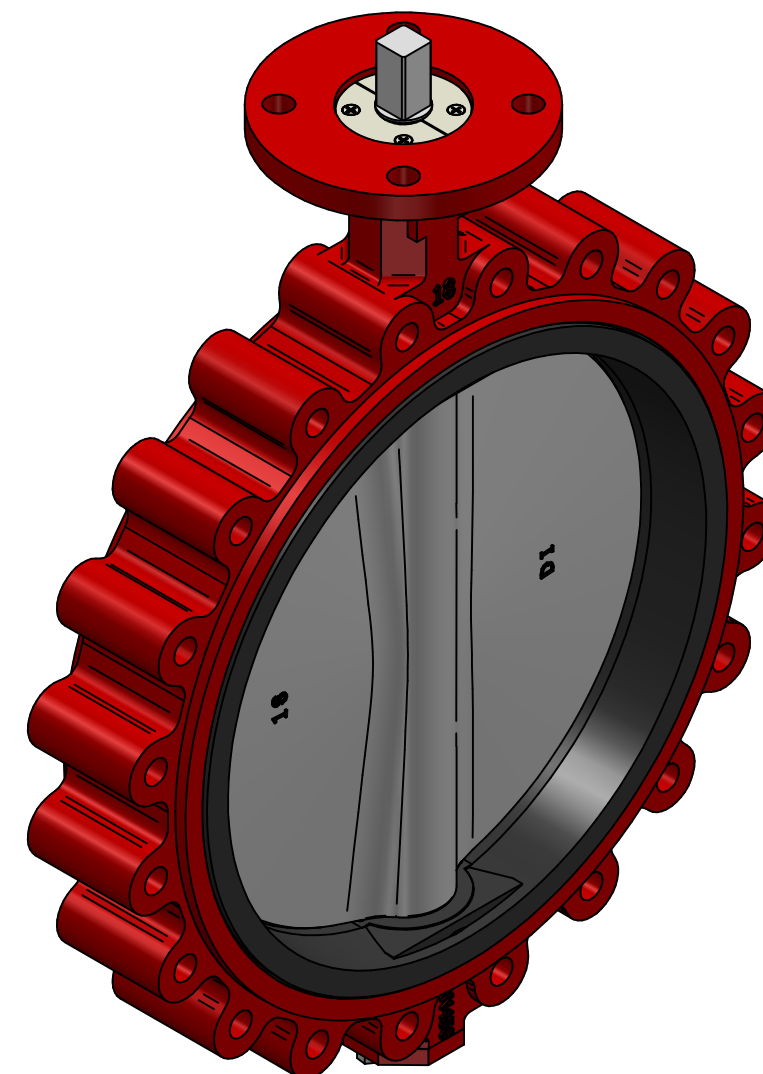

		NAME	DATE	SIZE	DWG NO
DRAWN	MOTO	09.04.2021	A3	QIF-110-011-0450	
CHECKED	ORLA	13.05.2023	FILE NAME: QIF-110-011-0450.dft		
ENG APPR	TOCO	dd.mm.yyyy	SCALE: 1:5	REV: 03	
MGR APPR	TOCO	dd.mm.yyyy	WEIGHT: 100 kg	SHEET: 1 OF 1	

UNLESS OTHERWISE SPECIFIED DIMENSIONS ARE IN MILLIMETERS AND TOLERANCES ARE +/-0,5

REV	DESCRIPTION	DATE	APPROVED
03	UPDATED WEIGHT	13.05.2023	JUWE
01	TOP FLANGE CONNECTION UPDATED	09.04.2021	MOTO
00	ISSUE	14.12.2016	RESO
REVISION HISTORY			

TITLE BUTTERFLY VALVE LUG DN450 / PN10