

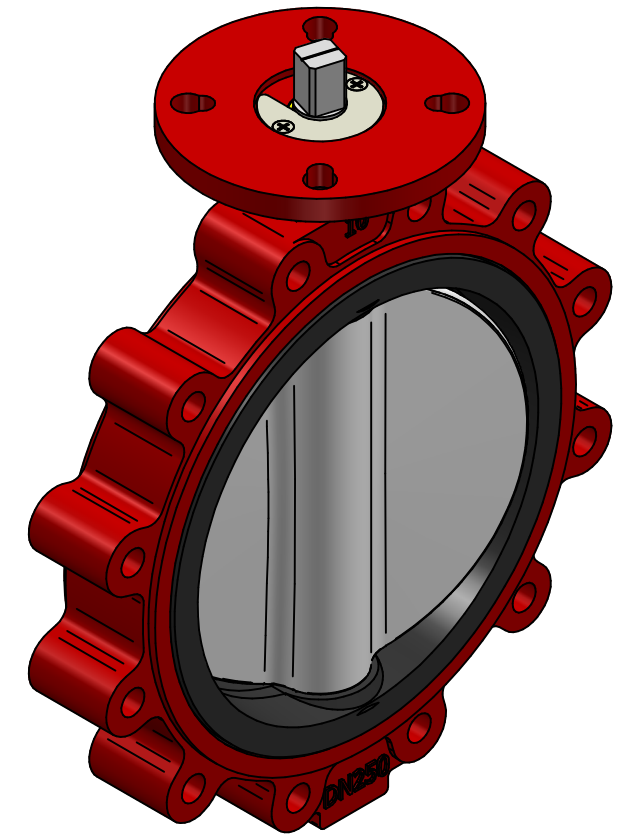

No.	Part Name	Material
1	Body	GGG40
2	Disc	DI+Nylon11
3	Shaft	SS416
4	Seat	EPDM

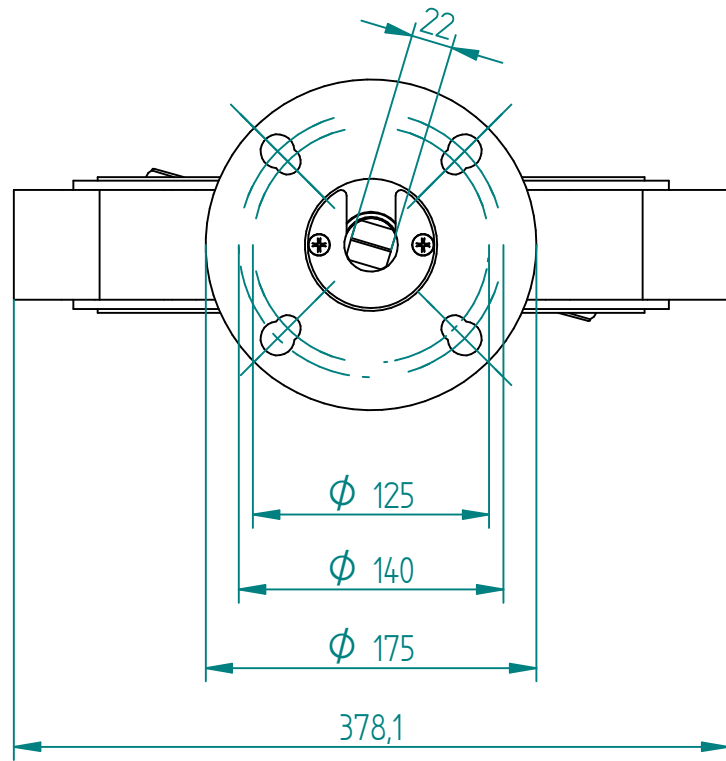
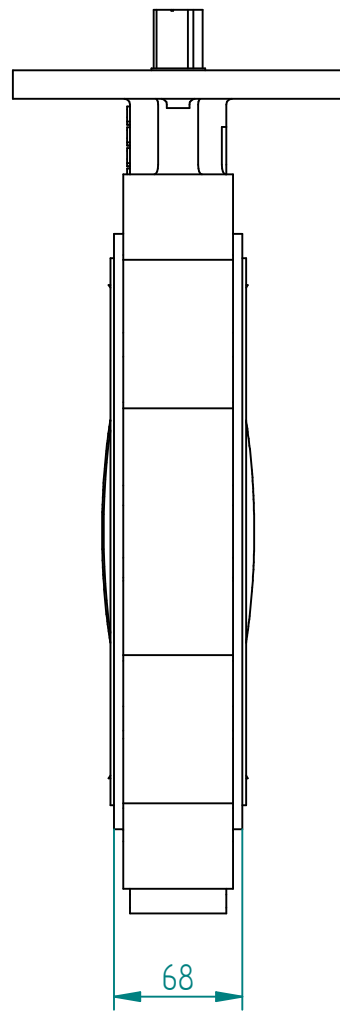
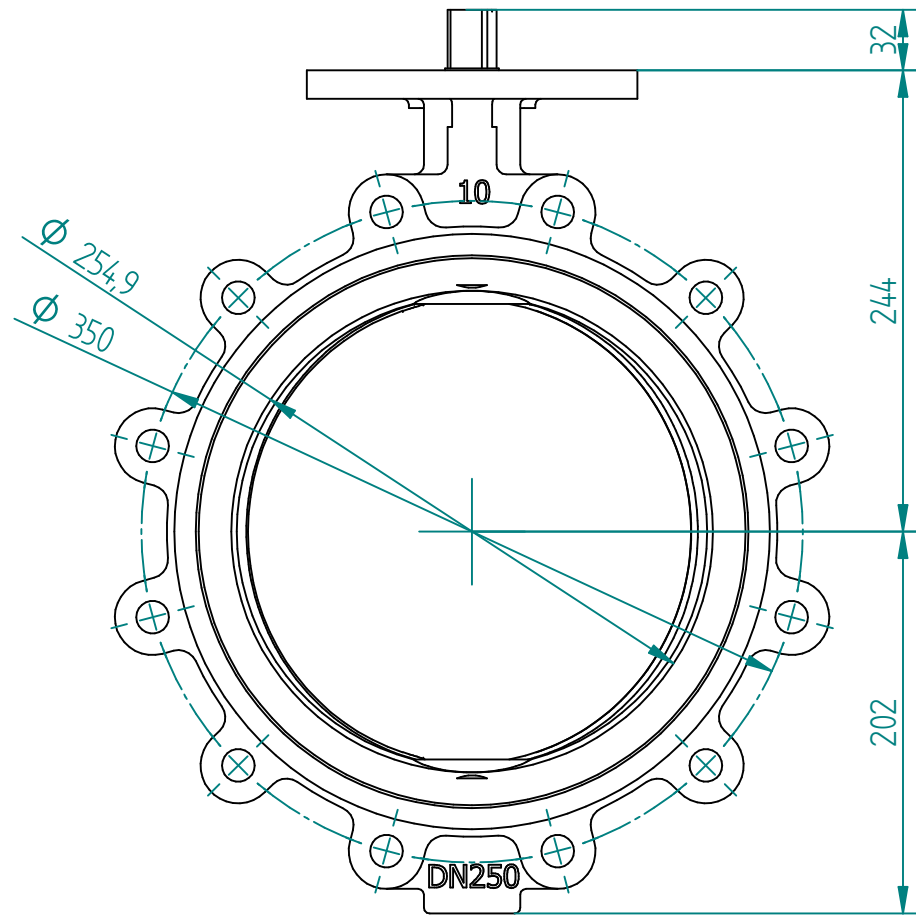

	NAME	MOTO	DATE	10/2/2020	SIZE	A3	DWG NO	QIF-110-011-0250
	DRAWN	MOTO	DATE	10/2/2020	FILE NAME:	QIF-110-011-0250.dft		
	CHECKED	ORLA	dd.mm.yyyy		SCALE:	1:4	REV:	01
	ENG APPR	TOCO	dd.mm.yyyy		WEIGHT:	24 kg	SHEET:	1 OF 1
MGR APPR	TOCO	dd.mm.yyyy						

UNLESS OTHERWISE SPECIFIED DIMENSIONS ARE IN MILLIMETERS AND TOLERANCES ARE +/-0,5

REV	DESCRIPTION	DATE	APPROVED
02	Updated Weight	13.10.2023	RAGA
REVISION HISTORY			

TITLE LUG BUTTERFLY VALVE
GGG40 DN250 PN10