

No.	Part Name	Material
1	Body	GGG40
2	Disc	DI+Nylon11
3	Shaft	SS416
4	Seat	EPDM

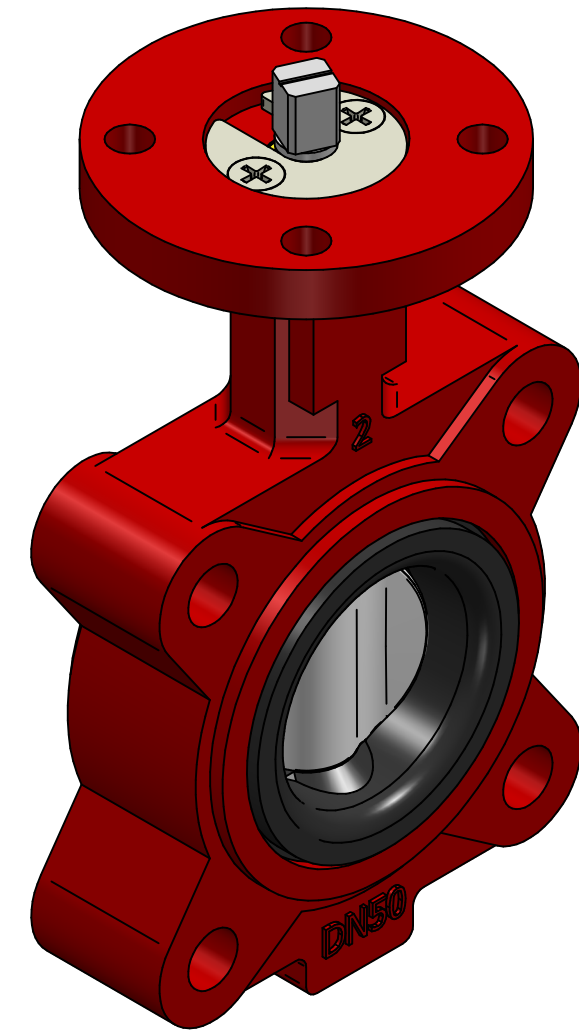

TITLE LUG BUTTERFLY VALVE  
GGG40 DN50 PN10

	NAME	DATE	SIZE	DWG NO
DRAWN	MOTO	11/23/2020	<b>A3</b>	QIF-110-011-0050
CHECKED	ORLA	dd.mm.yyyy	FILE NAME: QIF-110-011-0050.dft	
ENG APPR	TOCO	dd.mm.yyyy	SCALE: 1:1.5	REV: 02
MGR APPR	TOCO	dd.mm.yyyy	WEIGHT: 3,1 kg	SHEET: 1 OF 1

UNLESS OTHERWISE SPECIFIED  
DIMENSIONS ARE IN MILLIMETERS  
AND TOLERANCES ARE +/-0,5

REV	DESCRIPTION	DATE	APPROVED
01	Added weight	13/10/2023	RAGA
REVISION HISTORY			