

No.	Part Name	Material
1	Body	GGG40
2	Disc	DI+Nylon11
3	Shaft	SS416
4	Seat	EPDM
5	Lever	Mall Iron
6	Lever: Ratchet Plate	SS316
7	Lever: Bolts	A4-70

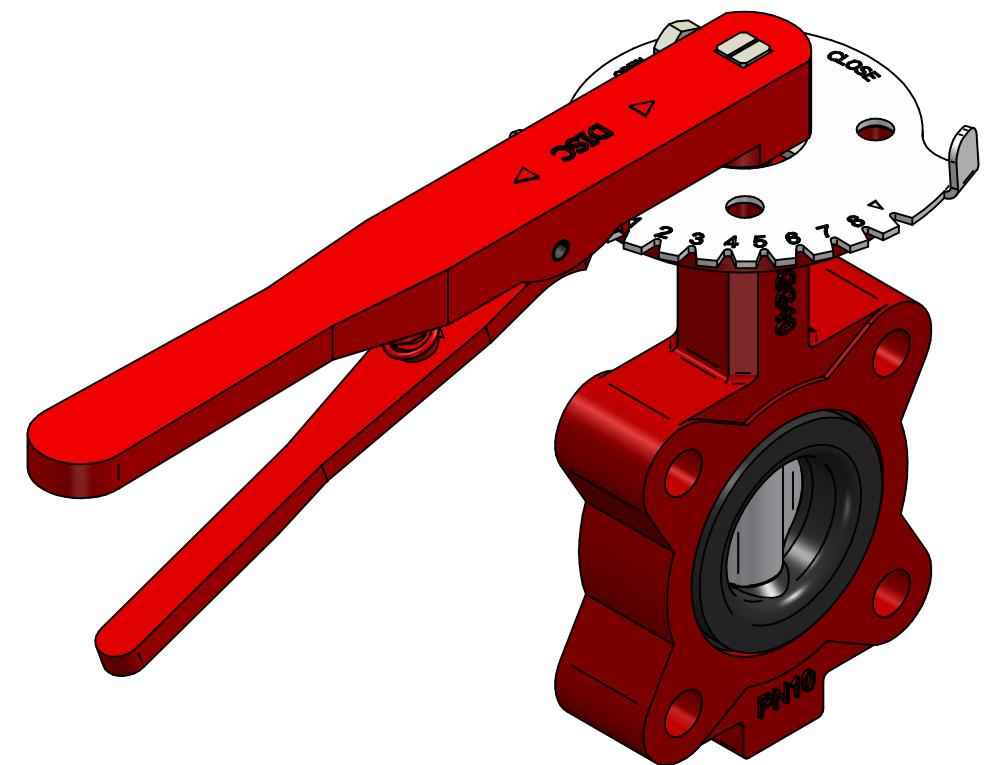
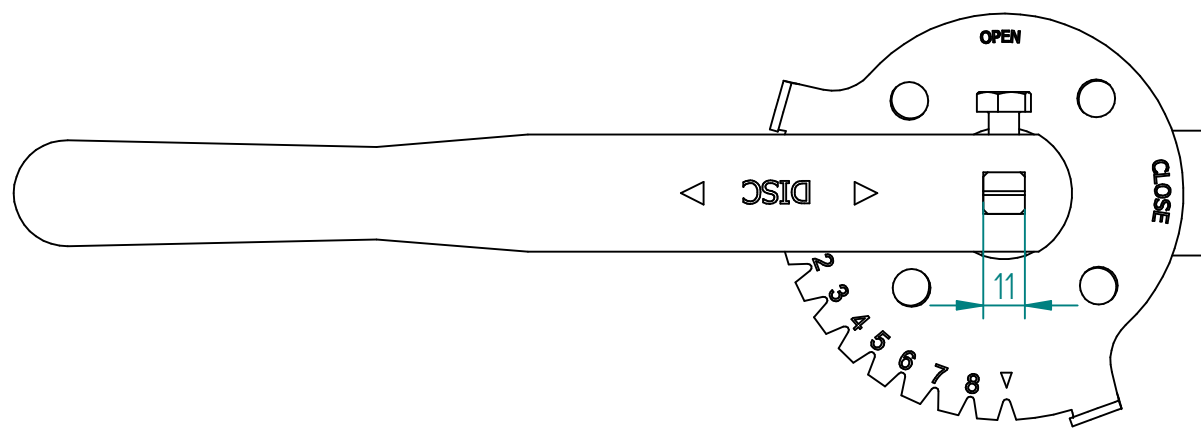
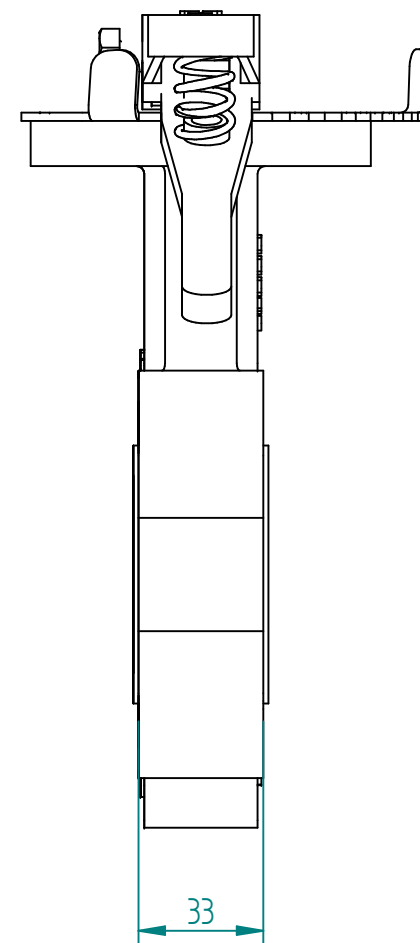
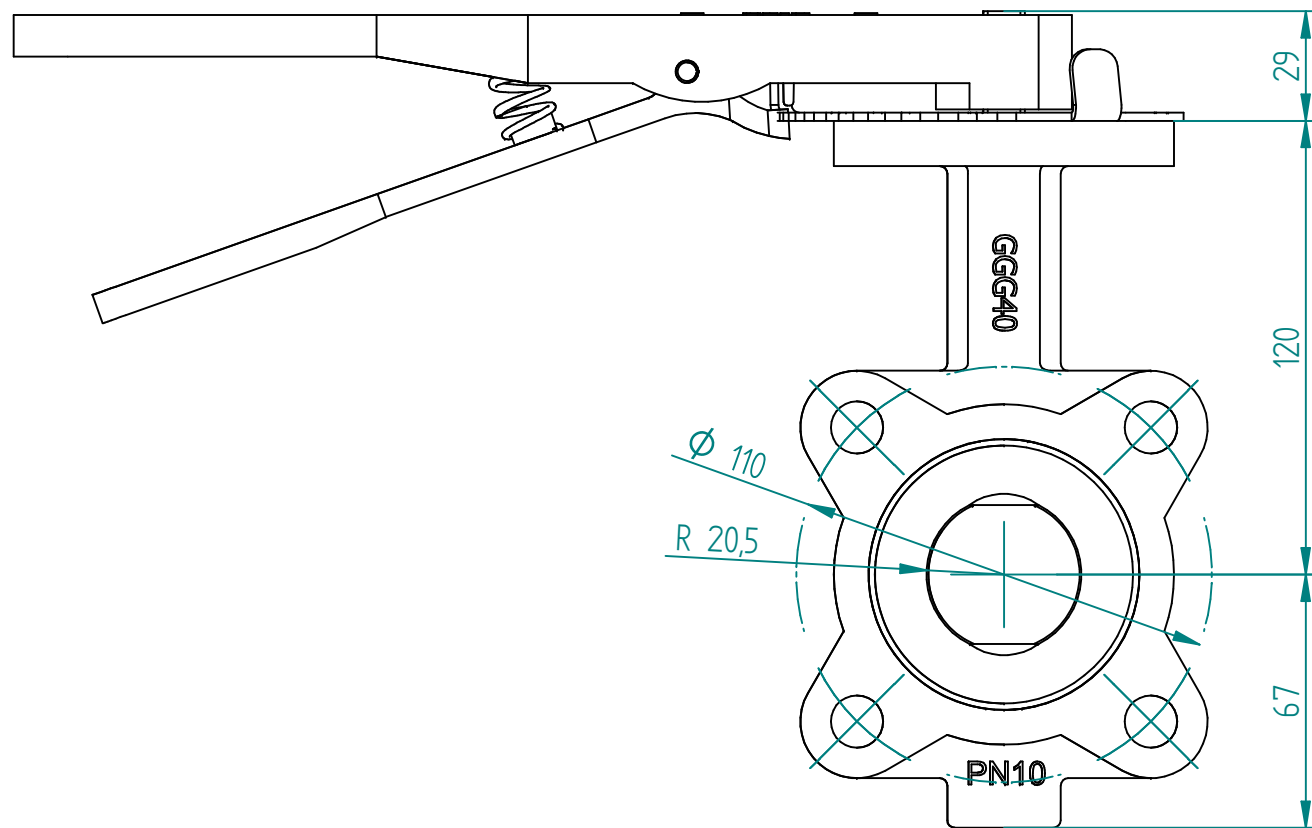

		NAME	DATE	SIZE	DWG NO
DRAWN	MOTO	03.05.2021	A3	QIF-110-001-040	
CHECKED	ORLA	dd.mm.yyyy	FILE NAME: QIF-110-001-0040.dft		
ENG APPR	TOCO	dd.mm.yyyy	SCALE: 1:2	REV: 03	
MGR APPR	TOCO	dd.mm.yyyy	WEIGHT: 2,9 KG	SHEET: 1 OF 1	

UNLESS OTHERWISE SPECIFIED DIMENSIONS ARE IN MILLIMETERS AND TOLERANCES ARE +/-0,5

REV	DESCRIPTION	DATE	APPROVED
03	ADDED WEIGHT TO DRAWING	03.05.2023	JUWE
02	UPDATED LEVER	04.05.2021	ORLA
01	UPDATED SQR CONNECTION	05.01.2021	ERKJ
REVISION HISTORY			

TITLE LUG BUTTERFLY VALVE GGG40 DN40 PN10 WITH LEVER