

DETAIL A

NO	PART NAME	MATERIAL	Quantity
1	BODY	CF8M	1
2	Cap	CF8M	1
3	Ball	SS316	1
4	Ball Seat	PTFE	2
5	Stem	SS316	1
6	Stem Packing	PTFE	2
7	O-Ring	Viton	1
8	Packing	PTFE	1
9	Gland	SS304	1
10	Washer	SS301	2
11	Nut	SS304	1
12	Thrust Washer	PTFE	1
13	Washer	SS304	2
14	Handle	SS304	1
15	Handle Cover	Plastic	1
16	Locking	SS304	1
17	Body Gasket	PTFE	1
18	Bolt	SS304	4

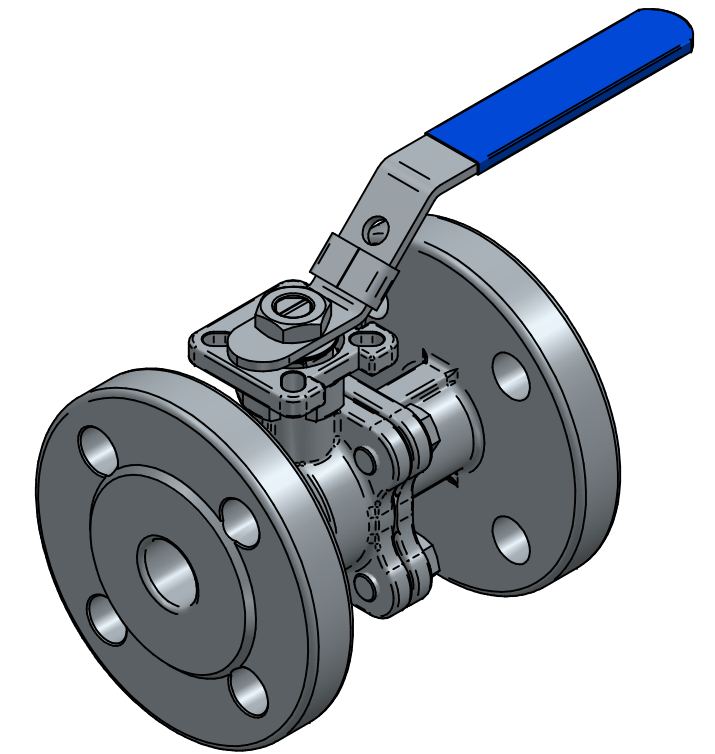

TITLE 2PC BALL VALVE FL. SS316 DN20 CLEANED FOR OXYGEN PN40 FLANGE CONNECTION, ø9mm F03/F04 TORQUE 8 N*M, API 598, PN16, PN25, PN40		NAME	DATE	SIZE	DWG NO	UNLESS OTHERWISE SPECIFIED DIMENSIONS ARE IN MILLIMETERS AND TOLERANCES ARE +/-0,5
	DRAWN	EMLA	5/16/2023	A3	QIF-100-OX2-0020	
	CHECKED	TOCO	dd.mm.yyyy	FILE NAME: QIF-100-OX2-0020.dft		
	ENG APPR	TOCO	dd.mm.yyyy	SCALE: 1:2	REV: 00	
	MGR APPR	TOCO	dd.mm.yyyy	WEIGHT: 3.38 kg	SHEET: 1 OF 1	

REV	DESCRIPTION	DATE	APPROVED
00	ISSUED	23.12.2023	RESO
REVISION HISTORY			