

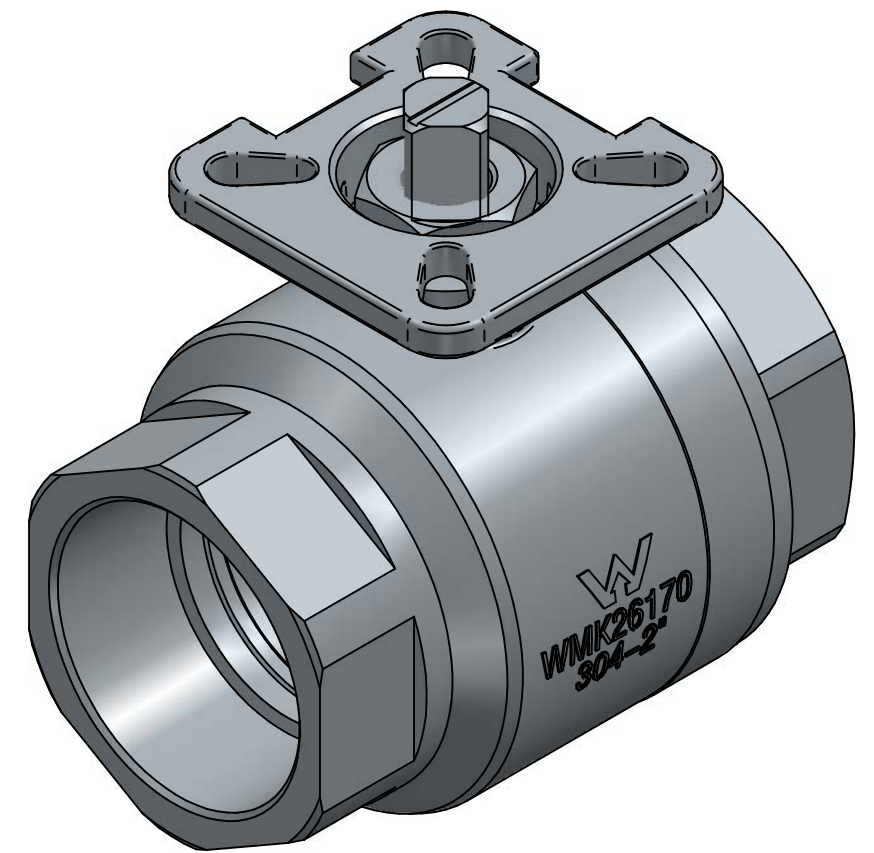

| No. | Part Name     | Material    | Qty |
|-----|---------------|-------------|-----|
| 1   | Body          | CF8M        | 1   |
| 2   | Ball Seat     | R-PTFE(15%) | 2   |
| 3   | Ball          | SS316       | 1   |
| 4   | Body Gasket   | PTFE        | 1   |
| 5   | Cap           | CF8M        | 1   |
| 6   | Stem          | SS316       | 1   |
| 7   | Thrust Washer | PTFE        | 1   |
| 8   | O-Ring        | Viton       | 1   |
| 9   | Stem Packing  | PTFE        | 1   |
| 10  | Packing Ring  | SS304       | 1   |
| 11  | Nut           | SS304       | 1   |

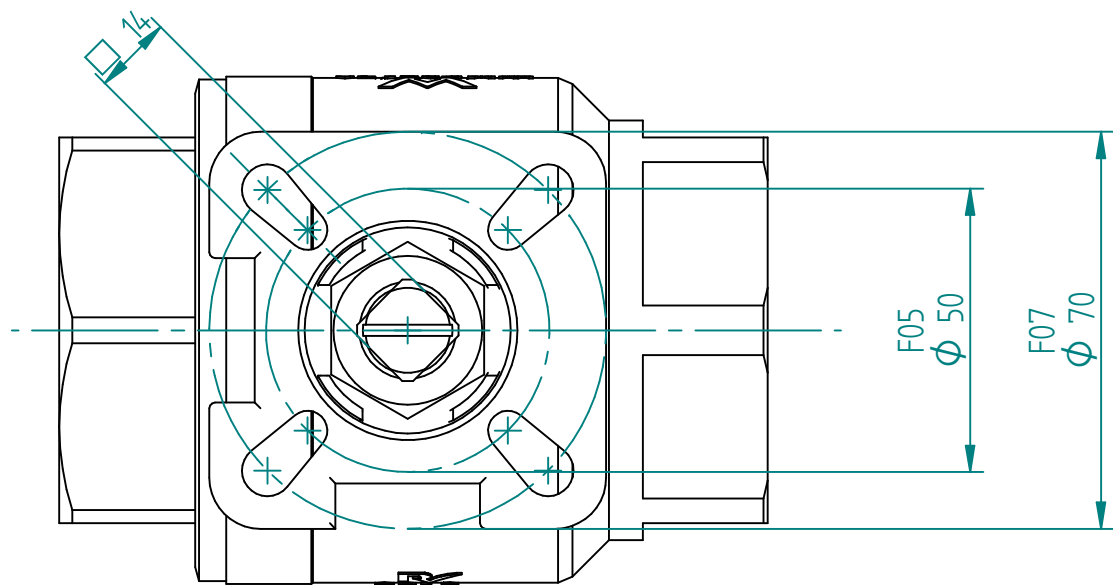

|                                                                                                                                                            |          |      |            |                                  |                                                                                    |
|------------------------------------------------------------------------------------------------------------------------------------------------------------|----------|------|------------|----------------------------------|------------------------------------------------------------------------------------|
|                                                                         | NAME     | DATE | SIZE       | DWG NO                           | UNLESS OTHERWISE SPECIFIED DIMENSIONS ARE IN MILLIMETERS AND TOLERANCES ARE +/-0,5 |
|                                                                                                                                                            | DRAWN    | EMLA | 5/16/2023  | A3 QIF-100-OX1-0050B             |                                                                                    |
|                                                                                                                                                            | CHECKED  | TOCO | dd.mm.yyyy | FILE NAME: QIF-100-OX1-0050B.dft |                                                                                    |
|                                                                                                                                                            | ENG APPR | TOCO | dd.mm.yyyy | SCALE: 3:4 REV: 00               |                                                                                    |
| TITLE                                                                                                                                                      | MGR APPR | TOCO | dd.mm.yyyy | WEIGHT: 3.05 kg                  | SHEET: 1 OF 1                                                                      |
| 2PC 2" ISO TOP BSP BALL VALVE SS316 CLEANED FOR OXYGEN<br>SS316 BODY, STEM, BALL AND SCREWS F05/F07 14mm<br>MOUNTING PAD, FULL BORE, BARE STEM Torque 25Nm |          |      |            |                                  |                                                                                    |

| REV              | DESCRIPTION | DATE     | APPROVED |
|------------------|-------------|----------|----------|
| 00               | ISSUED      | 16.05.23 | JOB      |
| REVISION HISTORY |             |          |          |