

No.	Part Name	Material	Qty
1	Body	CF8M	1
2	Ball Seat	R-PTFE(15%)	2
3	Ball	SS316	1
4	Body Gasket	PTFE	1
5	Cap	CF8M	1
6	Stem	SS316	1
7	Thrust Washer	PTFE	1
8	O-Ring	Viton	1
9	Stem Packing	PTFE	1
10	Packing Ring	SS304	1
11	Nut	SS304	1

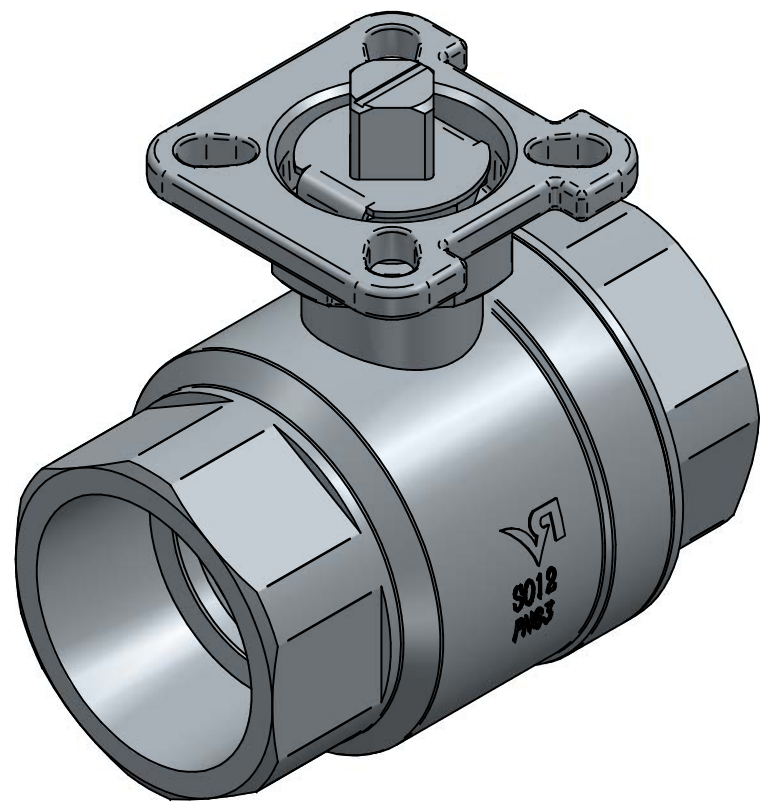
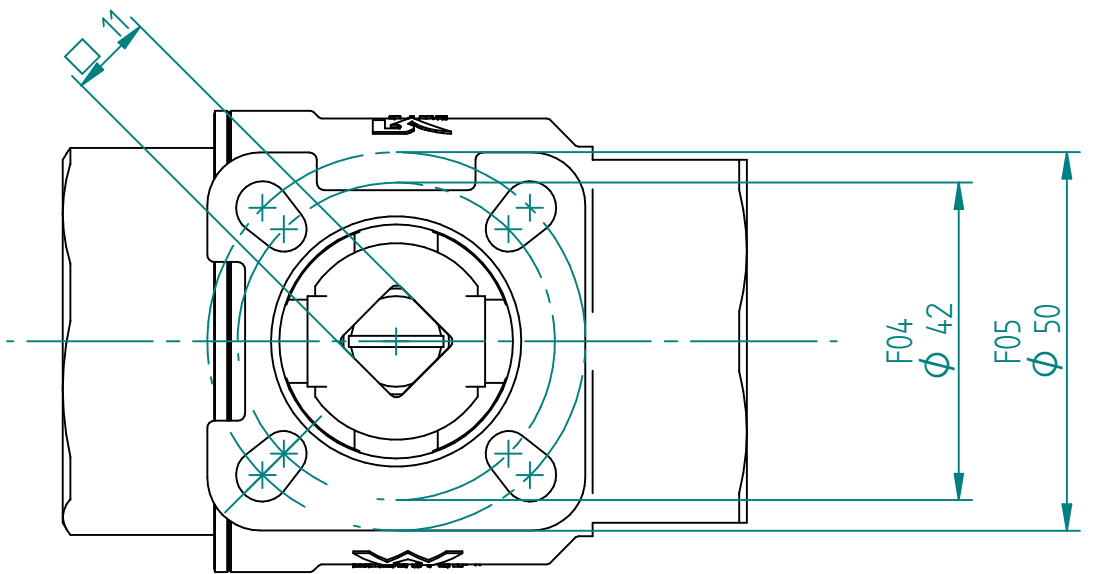

	NAME	DATE	SIZE	DWG NO
	DRAWN	EMLA	5/16/2023	A3 QIF-100-OX1-0032B
	CHECKED	TOCO	dd.mm.yyyy	FILE NAME: QIF-100-OX1-0032B.dft
	ENG APPR	TOCO	dd.mm.yyyy	SCALE: 1:1 REV: 00
MGR APPR	TOCO	dd.mm.yyyy	WEIGHT: 1.26 kg	SHEET: 1 OF 1

UNLESS OTHERWISE SPECIFIED DIMENSIONS ARE IN MILLIMETERS AND TOLERANCES ARE +/-0,5

REV	DESCRIPTION	DATE	APPROVED
00	ISSUED	16.05.23	JOB
REVISION HISTORY			

TITLE 2PC 1 1/4" ISO TOP BSP BALLVALVE SS316 CLEANED FOR OXYGEN, SS316 BODY, STEM, BALL AND SCREWS F04/F05 11mm, MOUNTING PAD, FULL BORE, BARE STEM