

No.	Part Name	Material	Qty
1	Body	CF8M	1
2	Ball Seat	R-PTFE(15%)	2
3	Ball	SS316	1
4	Body Gasket	PTFE	1
5	Cap	CF8M	1
6	Stem	SS316	1
7	Thrust Washer	PTFE	1
8	O-Ring	Viton	1
9	Stem Packing	PTFE	1
10	Packing Ring	SS304	1
11	Nut	SS304	1

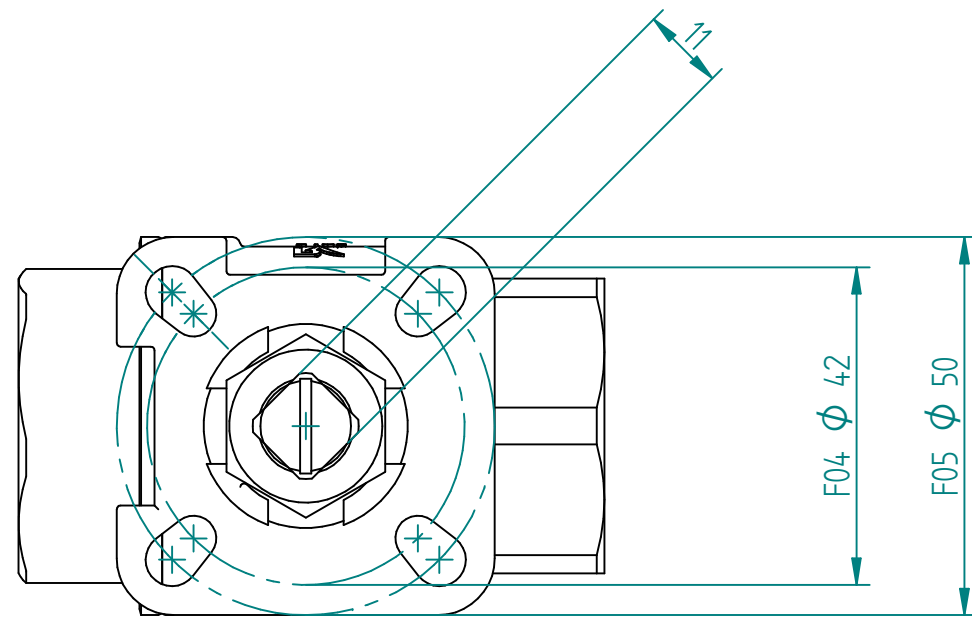

	NAME	DATE	SIZE	DWG NO
DRAWN	RAGA	12/11/2023	A3	QIF-100-OX1-0025B
CHECKED	TOCO	dd.mm.yyyy	FILE NAME: QIF-100-OX1-0025B.dft	
ENG APPR	TOCO	dd.mm.yyyy	SCALE: 1:1	REV: 01
MGR APPR	TOCO	dd.mm.yyyy	WEIGHT: 0.87 kg	SHEET: 1 OF 1

UNLESS OTHERWISE SPECIFIED  
DIMENSIONS ARE IN MILLIMETERS  
AND TOLERANCES ARE +/-0,5

REV	DESCRIPTION	DATE	APPROVED
00	Revised	11.12.23	HESG
00	Issued	12.10.22	HESG
REVISION HISTORY			

TITLE 2PC 1" ISO TOP BSP BALL VALVE CLEANED FOR OXYGEN  
SS316 BODY, STEM, BALL AND SCREWS F04/F05 11mm  
MOUNTING PAD, FULL BORE, BARE STEM