

No.	Part Name	Material	Qty
1	Body	CF8M	1
2	Ball Seat	R-PTFE(15%)	2
3	Ball	SS316	1
4	Body Gasket	PTFE	1
5	Cap	CF8M	1
6	Stem	SS316	1
7	Thrust Washer	PTFE	1
8	O-Ring	Viton	1
9	Stem Packing	PTFE	1
10	Packing Ring	SS304	1
11	Nut	SS304	1

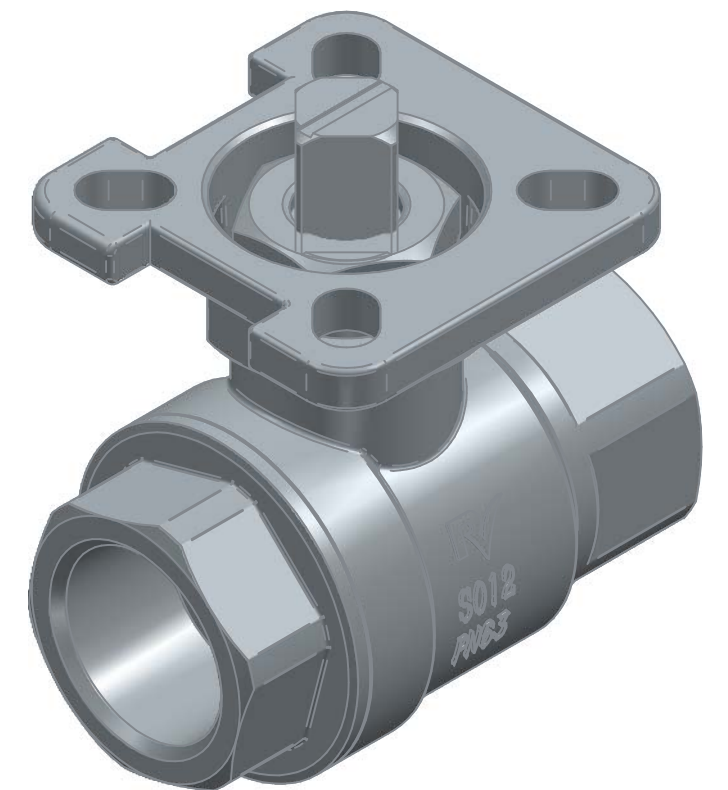
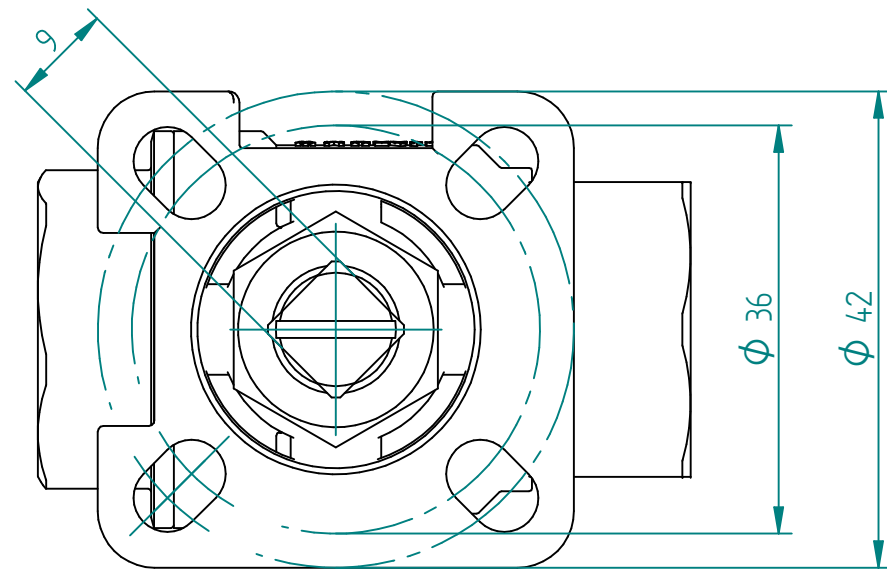

TITLE 15MM - 1/2" BSP 1000 PSI FULL BORE BALL VALVE	DRAWN	HESG	4/13/2023	SIZE <b>A3</b>	DWG NO QIF-100-001-0015B _ QIF-100-OX1-0015B
	CHECKED	RAGA	10/5/2023	FILE NAME: QIF-100-001-0015B _ QIF-100-OX1-0015B.dft	
	ENG APPR	TOCO	dd.mm.yyyy	SCALE: 1.5:1	REV: 00
	MGR APPR	TOCO	dd.mm.yyyy	WEIGHT: 0.38kg	SHEET: 1 OF 1

UNLESS OTHERWISE SPECIFIED DIMENSIONS ARE IN MILLIMETERS AND TOLERANCES ARE +/-0,5

REV	DESCRIPTION	DATE	APPROVED
00	Issued	14.09.22	
REVISION HISTORY			