

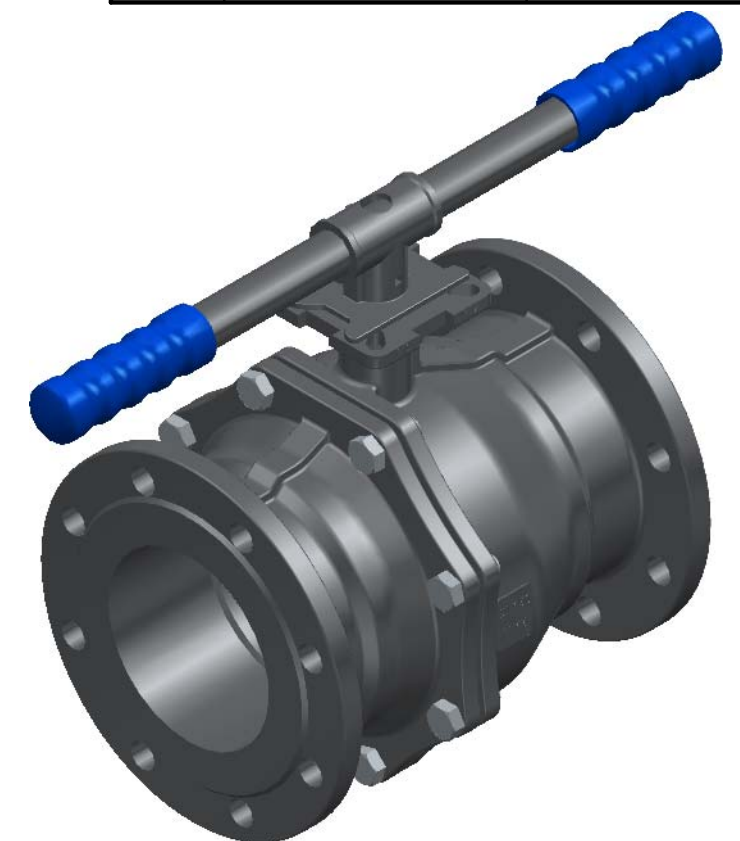

Pos	Part name	Material
1	Body	1.4408 (CF8M)
2	Cap	1.4408 (CF8M)
3	Ball	SS316
4	Ball seat	PTFE
5	Stem	SS316
6	Stem Packing	PTFE
7	O-Ring	VITON
8	V-Packing	PTFE
9	Gland	304
10	Washer	301
11	Nut	304
12	Thrust Washer	304
13	Washer	304
14	Handle	304
15	Plastic Cover	Plastic
16	Body Gasket	PTFE
17	Bolt	304



	NAME	DATE	SIZE	DWG NO	UNLESS OTHERWISE SPECIFIED DIMENSIONS ARE IN MILLIMETERS AND TOLERANCES ARE +/-0,5					
	DRAWN	RAGA	03.11.2023	A3		QIF-100-002-0150				
	CHECKED	TOCO	dd.mm.yyyy	FILE NAME: QIF-100-002-0150.dft						
	ENG APPR	TOCO	dd.mm.yyyy	SCALE: 1:5		REV: 00	REV	DESCRIPTION	DATE	APPROVED
MGR APPR	TOCO	dd.mm.yyyy	WEIGHT: 76.8 kg	SHEET: 1 OF 1	REVISION HISTORY					
TITLE 2PC BALL VALVE FLOATING DN150 FLANGED PN16 FULL BORE CF8M/316/PTFE ISO F10/12 SQR22 400NM										