

No.	Part Name	Material	Qty
1	Body	CF8M	1
2	Ball Seat	R-PTFE(15%)	2
3	Ball	SS316	1
4	Body Gasket	PTFE	1
5	Cap	CF8M	1
6	Stem	SS316	1
7	Thrust Washer	PTFE	1
8	O-Ring	Viton	1
9	Stem Packing	PTFE	1
10	Packing Ring	SS304	1
11	Nut	SS304	1

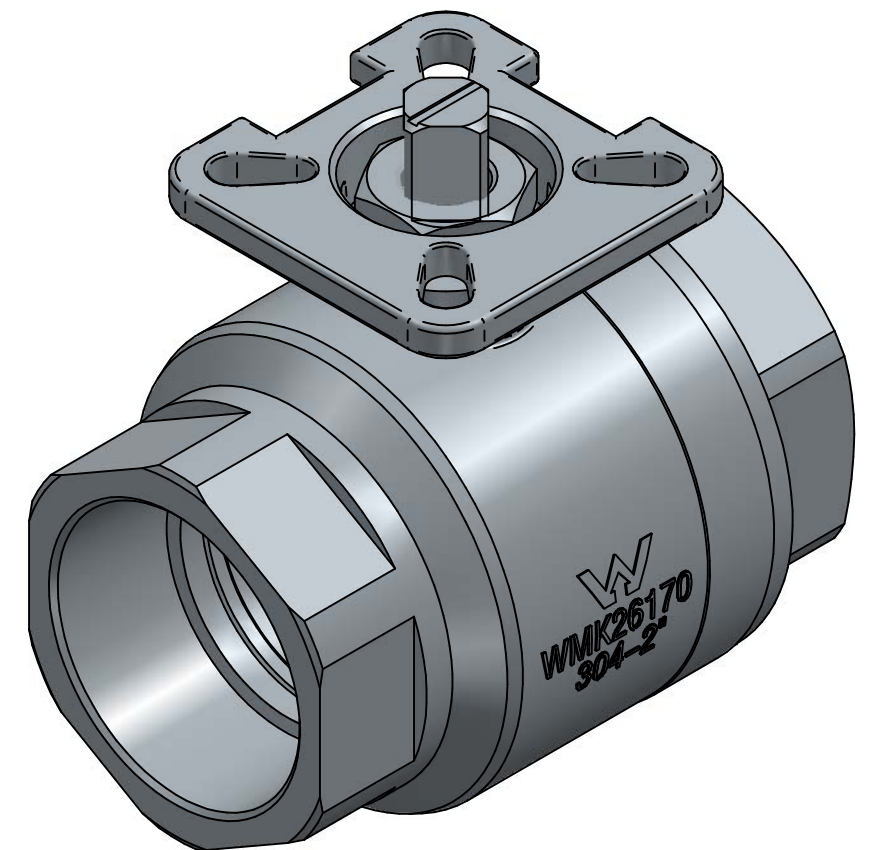
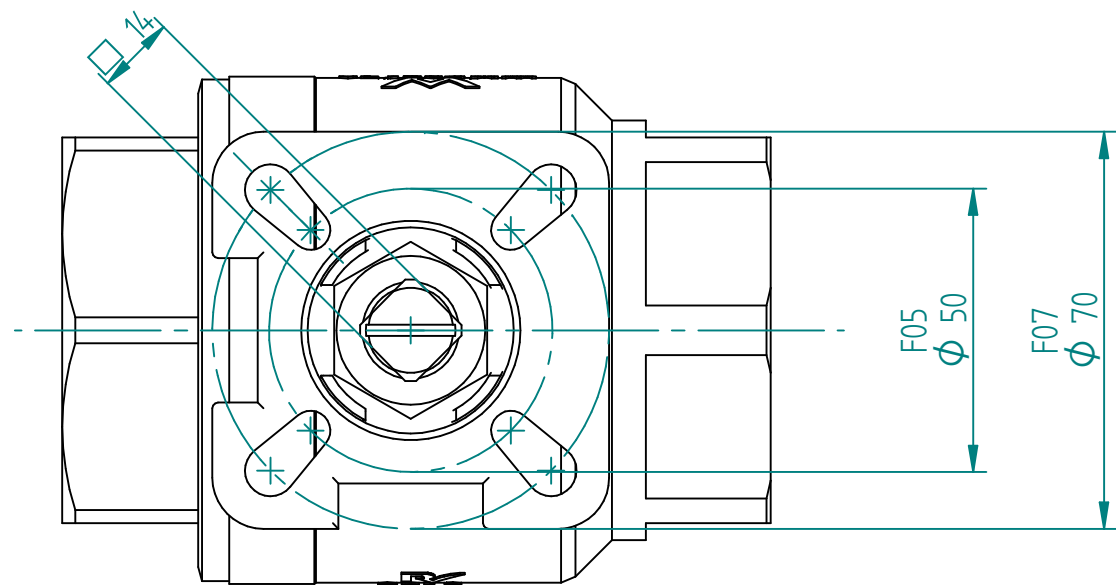

TITLE	NAME		DATE	SIZE	DWG NO
	DRAWN	EMLA	4/23/2023	A3	QIF-100-001-0050B
	CHECKED	RAGA	10/4/2023	FILE NAME: QIF-100-001-0050B.dft	
	ENG APPR	TOCO	dd.mm.yyyy	SCALE: 3:4	REV: 00
MGR APPR	TOCO	dd.mm.yyyy	WEIGHT: 3.05kg	SHEET: 1 OF 1	

UNLESS OTHERWISE SPECIFIED DIMENSIONS ARE IN MILLIMETERS AND TOLERANCES ARE +/-0,5

REV	DESCRIPTION	DATE	APPROVED
00	ISSUED	23.04.2023	JOB
REVISION HISTORY			