

EP5 Electropneumatic positioner

Product
Information

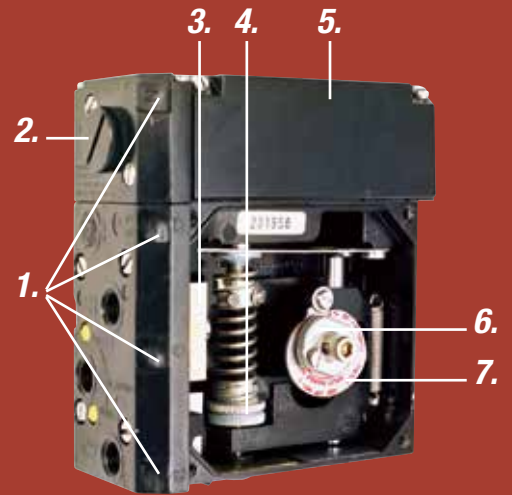

1. Gauge ports
2. Filter plug
3. Spool valve (High performance or Normal Gain)
4. Simple calibration of span & zero
5. I/P converter
6. Simple cam locking
7. Stainless cam



EP5 Electropneumatic Positioner

EP5

- Modular, sturdy, simple, reliable design.
- Tapped exhaust port.
- Easy to add on Feedback Unit F5.
- Simple calibration, external zero adjustment.
- High gain pilot valve.
- Built in gauge ports.
- Bright visible indicator, flat or Dome style.
- Stainless steel cam.

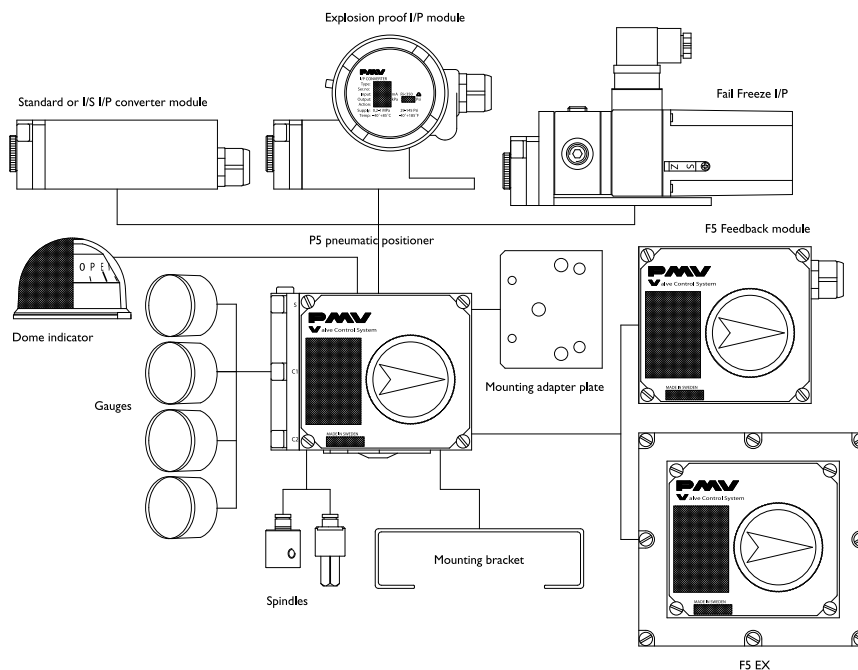



Technical data

Deadband	≤ 0.15%
Input signal	4–20 mA
Linearity	≤ 1%*
Hysteresis	≤ 0.75%*
Repeatability	≤ 0.5%*
Air supply	Max. 1 MPa/150 Psi, Oil, water and dustfree Min. 0.14 MPa/21 Psi
Connector threads	1/4" NPT or G (BSP)
Gauge threads	1/8" NPT or G (BSP)
Conduit entry	1/2" NPT or M20 x 1,5
Terminals	2.5 mm ² (AWG 14) Screw terminals

Gain factor at: 600 KPa/87 Psi

High Performance Version

Normal Gain Version

Min: 1000 KPa/KPa

Min: 450 KPa/KPa

Min: 66%/ % ISA S75.13-1989

Min: 30%/ %

Max. air consumption at supply pressure:

0.2 MPa/29 Psi	6.1 nl/min (0.22 SCFM)	2.7 nl/min (0.1 SCFM)
0.4 MPa/58 Psi	13.6 nl/min (0.48 SCFM)	6.1 nl/min (0.21 SCFM)
0.6 MPa/87 Psi	22 nl/min (0.78 SCFM)	9.9 nl/min (0.35 SCFM)
0.8 MPa/116 Psi	30.5 nl/min (1.08 SCFM)	13.7 nl/min (0.48 SCFM)
1 MPa/145 Psi	39 nl/min (1.38 SCFM)	17.5 nl/min (0.62 SCFM)

Min. air delivery at supply pressure:

0.2 MPa/29 Psi	200 nl/min (6.9 SCFM)	156 nl/min (5.5 SCFM)
0.4 MPa/58 Psi	370 nl/min (12.8 SCFM)	288 nl/min (10.1 SCFM)
0.6 MPa/87 Psi	540 nl/min (18.8 SCFM)	421 nl/min (14.8 SCFM)
0.8 MPa/116 Psi	710 nl/min (24.7 SCFM)	553 nl/min (19.4 SCFM)
1 MPa/145 Psi	880 nl/min (30.6 SCFM)	686 nl/min (24 SCFM)

Input impedance	170–260 Ohms at 20°C (71°F)
RFI influence	Not measurable
Capacitance	Negligible
Position sensitivity	None
Supply pressure effect	0.5%/0.1 MPa (15 Psi)
Temperature range	–20°C to +85°C/(–4°F to +185°F)
Low temp option	–40°C to +85°C/(–40°F to +185°F)
Weight	1.5 kg/3.4 lbs
Housing	Die cast aluminum
Surface treatment	ED Epoxy paint, black
Fasteners	A2/A4 Stainless
Ingress protection	IP 66/NEMA 4

Approvals

ATEX	Intrinsically safe	EEx ia IIC T4–T6 Ⓢ II 1 G	Non-electrical device P5 Ⓢ II 1 G
	Flameproof**	EEx d IIB+H2 T4–T6 Ⓢ II 2 G	
FM	Intrinsically safe	Div.1, Class 1 Group ABCD	
	Explosion proof**	Div.1, Class 1 Group BCD	
CSA	Intrinsically safe	Div.1, Class 1 Group ABCD	
	Explosion proof**	Div.1, Class 1,2,3 Group BCDEFG	

* Percent of full scale

** I/P in round housing

Spindles

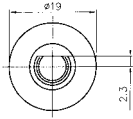

S 39

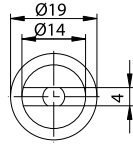
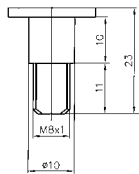

S23

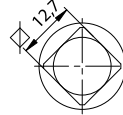
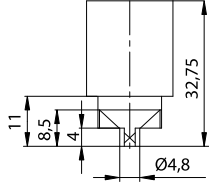

S30

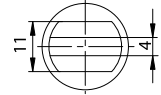
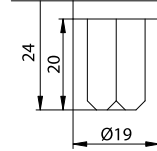

S36

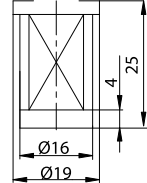

Dimensions drawings (mm)

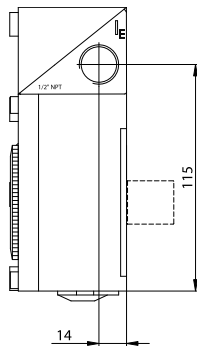

EP5

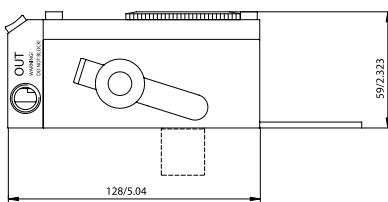
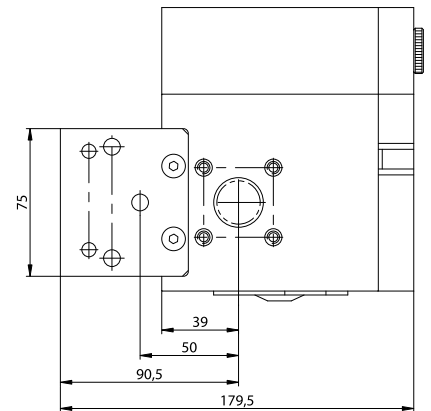
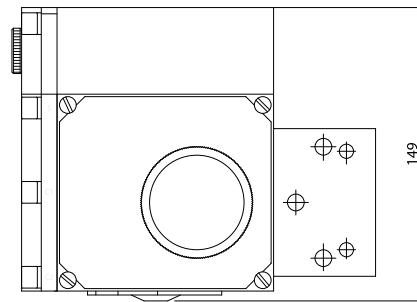

EP5

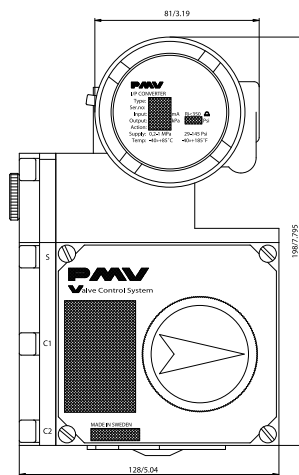

EP5 EX

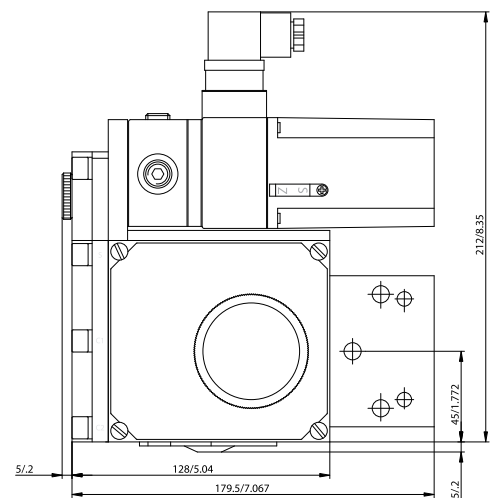

EP5-FS



Modular

- EP5 For all normal applications
- EP5-EX Explosion proof
- EP5-FS Fail freeze
- EP5-IS Intrinsically safe



EP5 Series Coding

Model	
EP5XX	EP5 Double acting pneumatic
EP5FS	Fail freeze function
EP5IS	Intrinsically safe, ATEX, FM, CSA
EP5EX	Explosion proof ATEX
Spool valve	
HP	High performance
LB	Normal Gain
Connections	
N	NPT 1/4", El. 1/2" NPT
G	G 1/4" air, M20 x 1,5 electric
M	NPT 1/4" air, M20 x 1,5 electric
Surface treatment	
U	Epoxy coating
M	Tufram
Spindle	
01, 23 etc	01 to 39. See dwg SPNDLS_P5
Cam	
K01, K08 etc	K01 to K34
Front cover	
PV9DA*	90°, Direct, arrow indicator
Input signal	
4	4-20 mA input
Temperature	
N	Nitrile seals -20°C to +85°C
Q	Silicon seals -40°C to +85°C

*For 30, 45, 60 deg rotation, change PV9 to PV3, PV4 or PV6

Example
EP5XX-HPNU-23K01-PV9DA-4Z

Cams

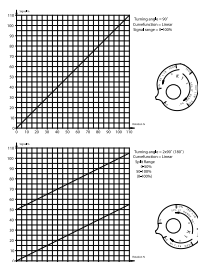

K1

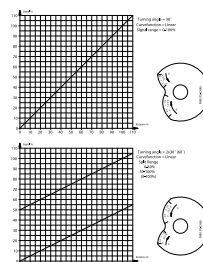

K3

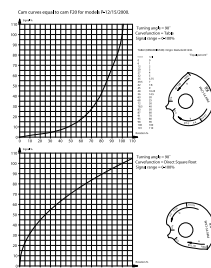

K8