

Safety-Valve, springloaded

for steam, gases and liquids in closed completion

Typ 30

Standard version:

Material:	Inlet body	/ Spring bonnet, outlet body	Temperature ranges metal seated
Typ 30.1:	BG I 1.0460	/ 0.7043	-10°C to 280°C
	BG II - IV 1.0619	/ 1.0619	-10°C to 350°C
Typ 30.2:	BG I 1.4571	/ 1.4581	-60°C to 280°C
	BG II - IV 1.4571, 1.4581	/ 1.4581	-60°C to 350°C
Typ 30.7:	BG I - IV 1.4571	/ 1.4308	-200°C to 280°C
Connections:			soft seated
Flange connections: DIN EN / ASME B16.5			see techn. appendix: KWD-1

Approvals:

Pressure Equipment Directive: 97/23/EG
Declaration of Conformity



TÜV - Approval:

VdTÜV-leaflet AD 2000-leaflet A 2 TÜV • SV • XX-713 / 820 / 896 / 902 • do • D/G/F • α_w • p

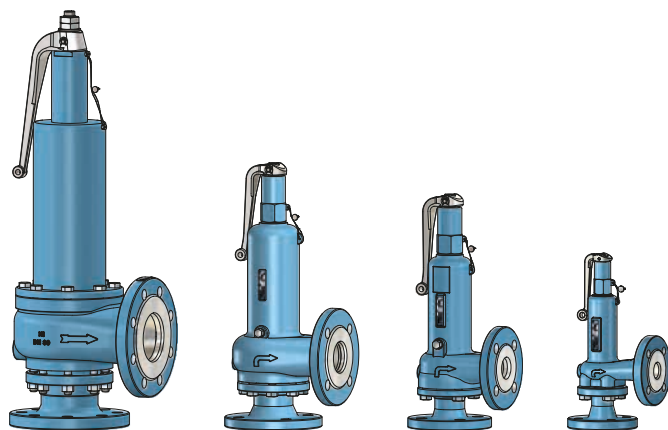
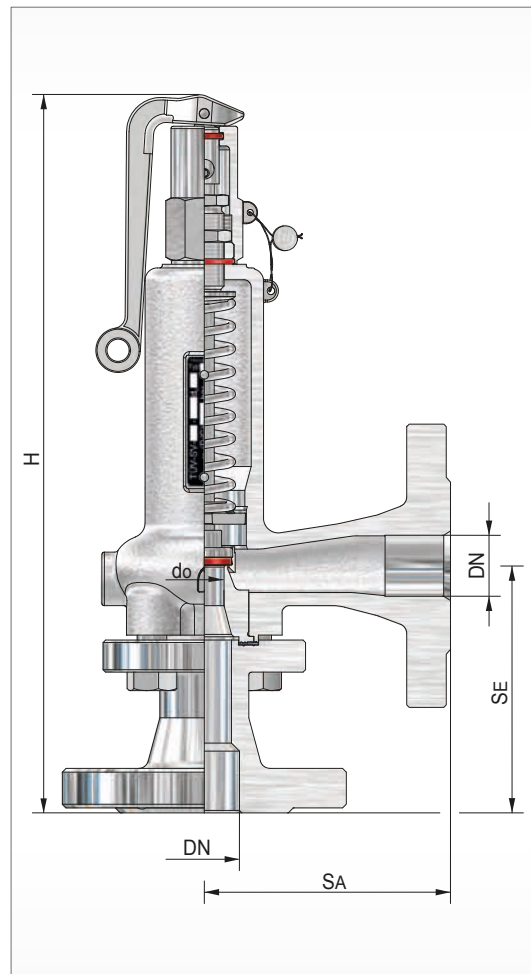

Size IV

Size III

Size II

Size I

Size	Inlet				Outlet				Height 'H' for head			Coefficient		Set pressure		Weight
	DN	NPS	PN / Class	do	SE	DN	NPS	PN / Class	SA	A	C	D/G	F	p min.	p max.	
				[mm]	[mm]				[mm]	[mm]	[mm]	α _w max.	α _w	[bar(g)]	[bar(g)]	~ [kg]
I	15	1/2	16-63 150-600	12,5	90	15	1/2	16-40 150-300	90	282	268	0,45	0,32	0,20	40	4,3
	20	3/4		12,5	95	20	3/4		95	287	273	0,45	0,32	0,20	40	4,5
	25	1		16	100	25	1		100	292	278	0,38	0,29	0,15	40	5,2
II	32	1 1/4	16-63 150-600	20	105	32	1 1/4	16-40 150-300	105	395	375	0,43	0,34	0,10	40	10,0
				25	115	40	1 1/2					115	405		0,31	0,24
	40	1 1/2		25	115	40	1 1/2		115	405		385	0,41	0,32	40	10,7
III	50	2	16-63 150-600	32	125	50	2	16-40 150-300	125	450	430	0,39	0,28	0,05	40	17,0
				40	145	65	2 1/2					145	470		0,31	0,23
	65	2 1/2		40	145	65	2 1/2		145	470		450	0,31		0,23	36
IV	80	3	16-63 150-600	50	155	80	3	16-40 150	155	700	620	0,46	0,33	0,08	25	38,0
				58	175	100	4					175	730		0,41	0,29
	100	4		60	175	100	4		175	730		650	0,44	0,30	0,05	18
				70								0,40	0,28	6	40,5	
				70									0,41	6	40,5	

other design on request

Safety-Valve, springloaded

for steam, gases and liquids in closed completion

Typ 30

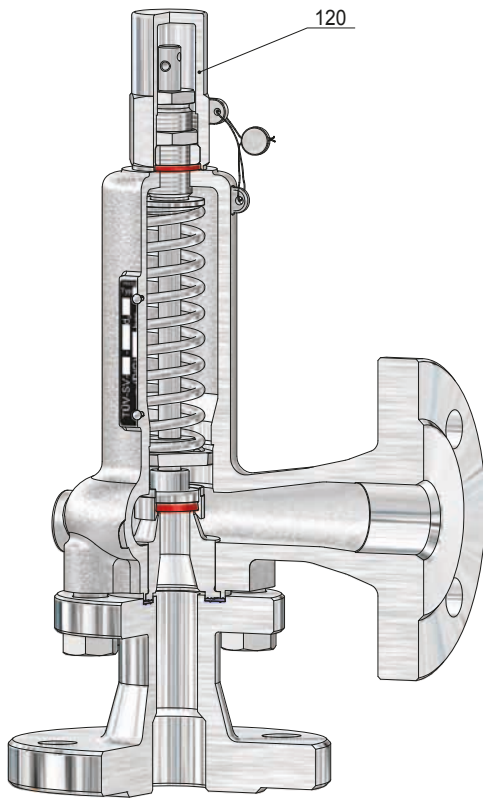

Size I
head C

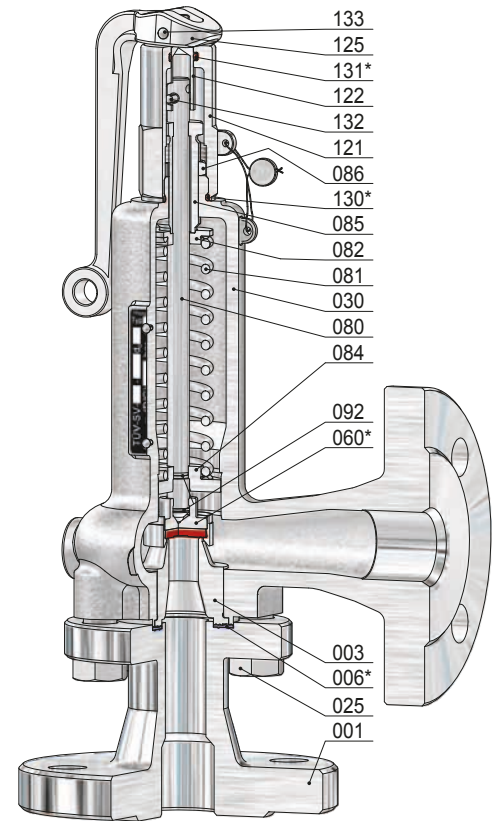

Size I
head A

Item	Piece	Description	Item	Piece	Description
001	1	inlet body	086	1	lock nut
003	1	seat	092	2	lock ring
006 *	1	packing ring	120	1	cap
025	4	screw	121	1	lifting cap
030	1	spring bonnet	122	1	coupling
060 *	1	disc, complete	125	1	lifting button
560	1	disc	130 *	1	o-ring
062	1	soft sealing	131 *	1	o-ring
063	1	disc ring	132	1	groove pin
080	1	spindle	133	1	groove pin
081	1	spring			
082	1	springplate, upper			
084	1	springplate, lower			
085	1	adjusting screw			

* expendable parts

Safety-Valve, springloaded

for steam, gases and liquids in closed completion

Typ 30

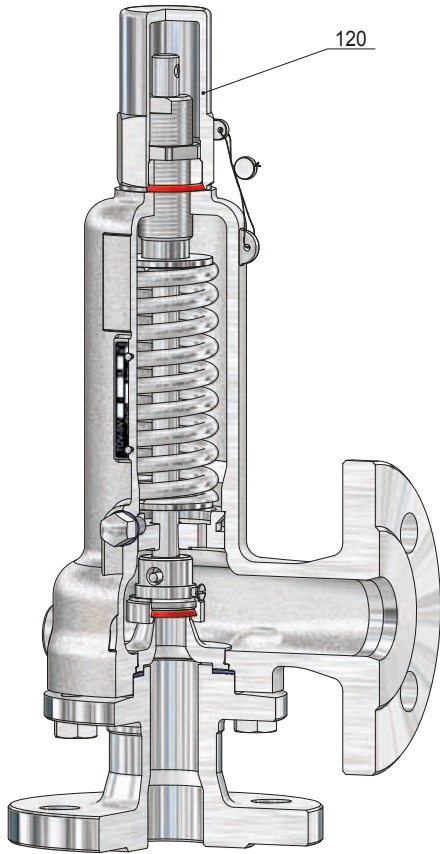

Size II
head C

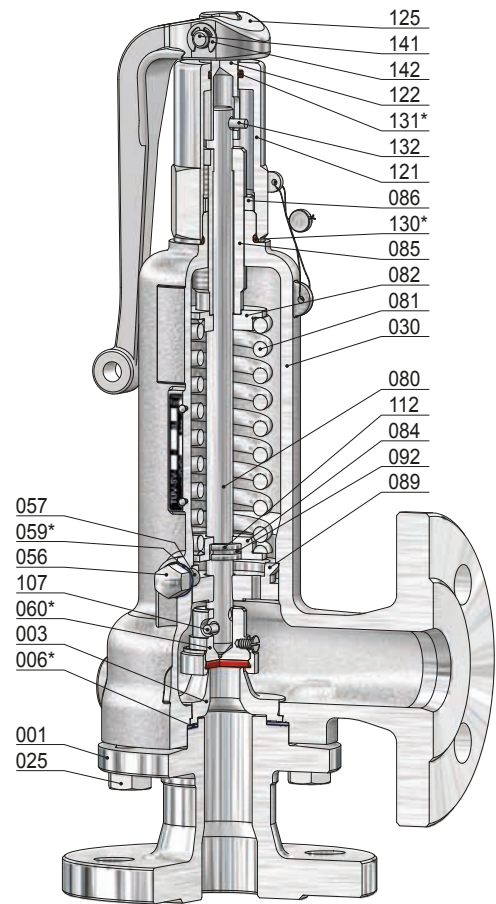

Size II
head A

Item	Piece	Description	Item	Piece	Description
001	1	inlet body	085	1	adjusting screw
003	1	seat	086	1	lock nut
006 *	1	packing ring	089	1	guide plate
025	4	screw	092	1	lock ring
030	1	spring bonnet	107	1	spring pin
056	2	lock nut	112	1	split ring
057	2	screwed pin	120	1	cap
059 *	2	packing ring	121	1	lifting cap
060 *	1	disc, complete	122	1	coupling
062	1	disc	125	1	lifting button
063	1	soft sealing	130 *	1	o-ring
067	1	disc ring	131 *	1	o-ring
080	1	security screw	132	1	groove pin
081	1	spindle	141	1	bolt
082	1	spring	142	2	stop washer
084	1	springplate, upper			
		springplate, lower			

* expendable parts

Safety-Valve, springloaded

for steam, gases and liquids in closed completion

Typ 30

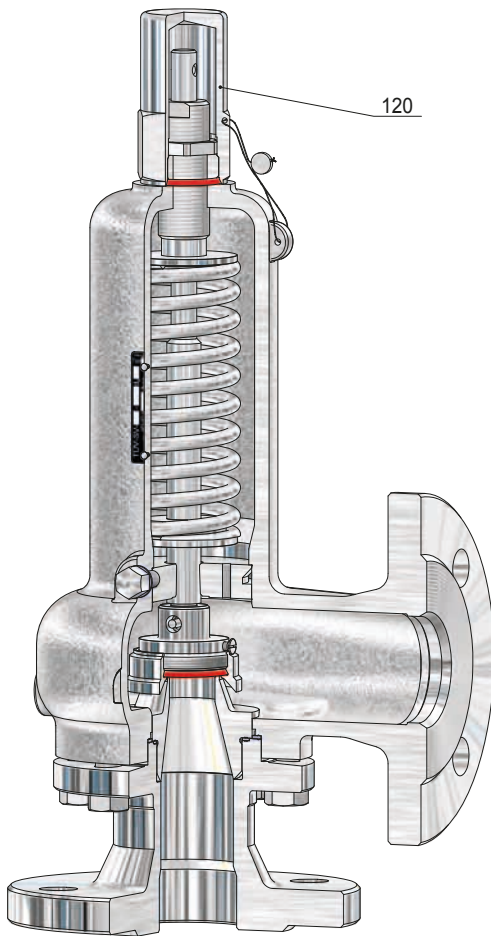

Size III
head C

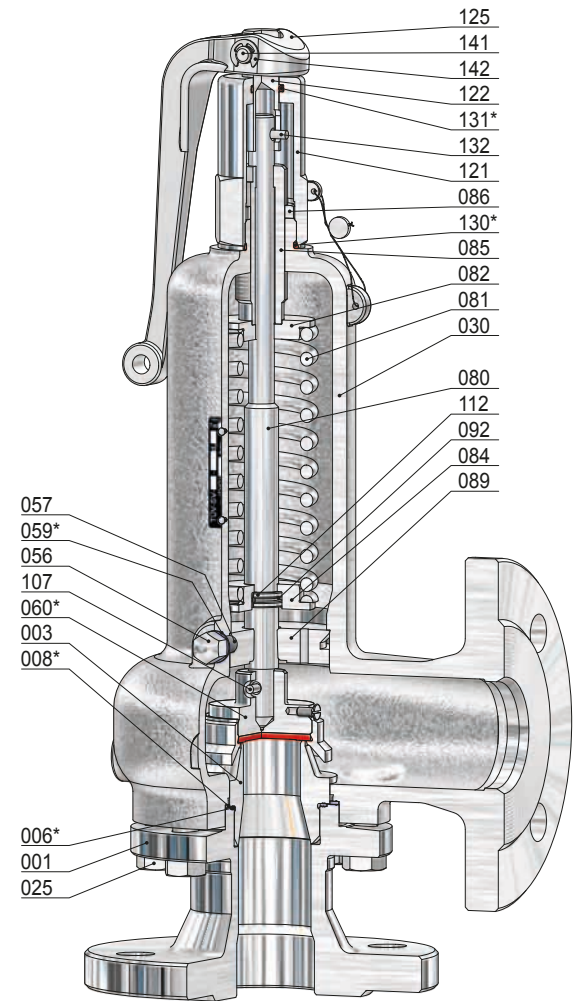

Size III
head A

Item	Piece	Description	Item	Piece	Description
001	1	inlet body	084	1	springplate, lower
003	1	seat	085	1	adjusting screw
006 *	1	packing ring	086	1	lock nut
008 *	1	packing ring	089	1	guide plate
025	8	screw	092	1	lock ring
030	1	spring bonnet	107	1	spring pin
056	2	lock nut	112	1	split ring
057	2	screwed pin	120	1	cap
059 *	2	packing ring	121	1	lifting cap
060 *	1	disc, complete	122	1	coupling
062	1	disc	125	1	lifting button
063	1	disc ring	130 *	1	o-ring
067	1	security screw	131 *	1	o-ring
080	1	spindle	132	1	groove pin
081	1	spring	141	1	bolt
082	1	springplate, upper	142	2	stop washer

* expendable parts

Safety-Valve, springloaded

for steam, gases and liquids in closed completion

Typ 30

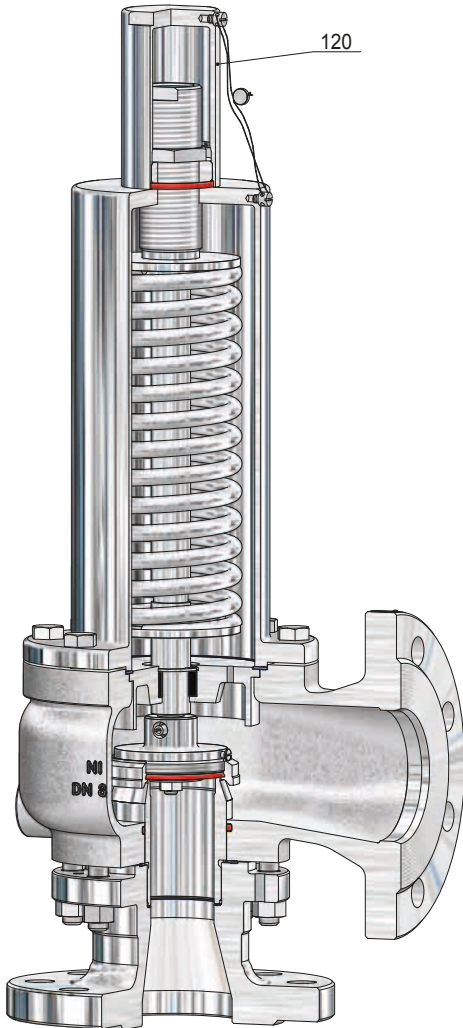

Size IV
head C

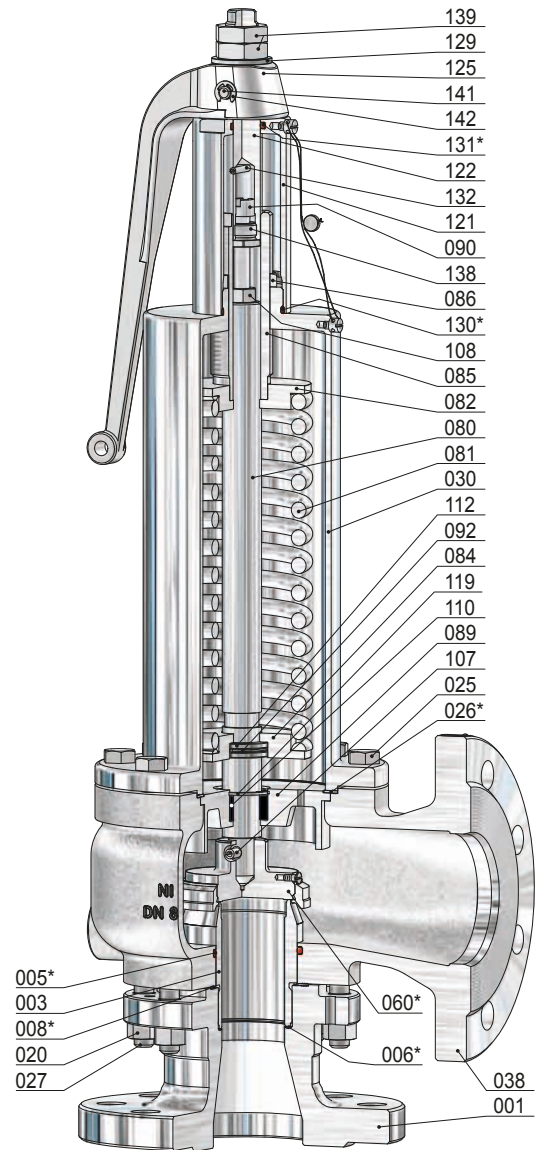

Size IV
head A

Item	Piece	Description	Item	Piece	Description	Item	Piece	Description
001	1	inlet body	073	1	o-ring	121	1	lifting cap
003	1	seat	074	1	disc plate	122	1	coupling
005 *	1	o-ring	080	1	spindle	125	1	lifting button
006 *	1	packing ring	081	1	spring	129	1	pressure plate
008 *	1	packing ring	082	1	springplate, upper	130 *	1	o-ring
020	8	nut	084	1	springplate, lower	131 *	1	o-ring
025	8	screw	085	1	adjusting screw	132	1	groove pin
026 *	1	packing ring	086	1	lock nut	138	1	screw
027	8	stud bolt	089	1	guide plate	139	2	nut
030	1	spring bonnet	090	1	screw	141	1	bolt
038	1	outlet body	092	1	lock ring	142	2	stop washer
060 *	1	disc, complete	107	1	spring pin			
560	1	disc	108	1	nut			
062	1	soft sealing	110	1	bush			
063	1	disc ring	112	1	split ring			
065	1	disc bolt	119	1	locking ring			
067	1	security screw	120	1	cap			

* expendable parts