

Relief-Valve, springloaded

for steam, gases and liquids in closed completion

Typ 5

Standard version:

	Material:		Temperature ranges	
	Inlet body	/ Spring bonnet	soft seated	
Typ 5.2:	1.4581	/ 1.4571	-40°C to 130°C	
Typ 5.3:	2.0401	/ 2.0401	-10°C to 130°C	
	Connections:		only elastomers	
	Screwed connection: DIN ISO 228 / ASME B1.20.1 / Ermeto		see techn. appendix: KWD-1	

Approvals:

Pressure Equipment Directive: 97/23/EG
Declaration of Conformity

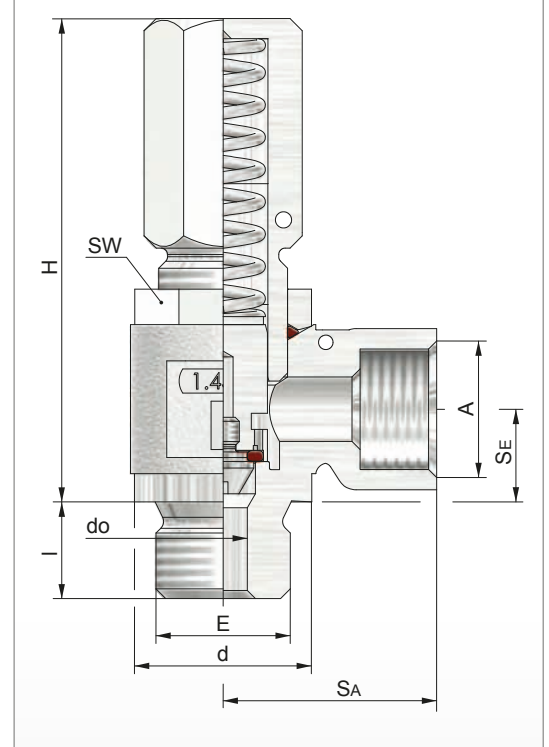
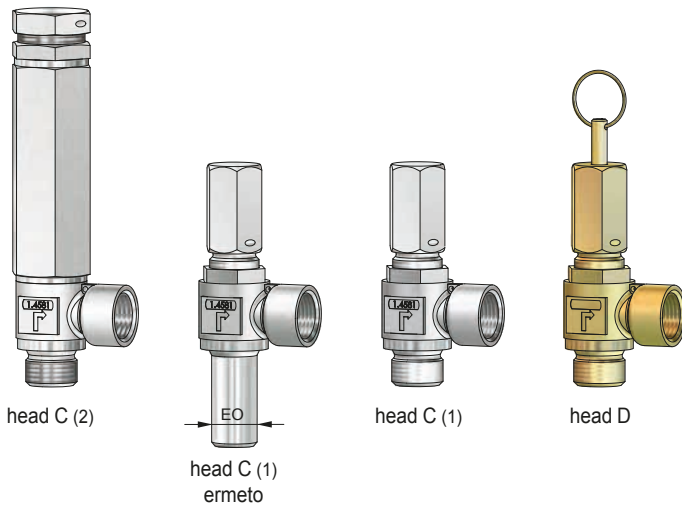

Type	Inlet						Outlet			Dimensions			Height 'H' for head			Set pressure		Weight ~ [kg]		
	E	SE	d	l (G)	l (NPT)	EO Ø	A	SA	t (G)	SW	do	seat Ø	C (1)	C (2)	D	p min.	p max.			
	[mm]	[mm]	[mm]	[mm]	[mm]	[mm]	[mm]	[mm]	[mm]	[mm]	[mm]	[mm]	[mm]	[mm]	[mm]	[bar(g)]	[bar(g)]			
5.2	1/4	11,5	18	12	17	3/8	26	9,5		22	6	6	55	72		0,4	65	0,15		
	3/8		22	12	17															
	EO		22	26	26														12	
	1/4		18	12	17															
	3/8		22	12	17															
	EO		22	26	26														12	
	1/4		18	12	17															
	3/8		22	12	17															
5.3	1/4	11,5	18	12	17	3/8	26	9,5		22	6	8	55	72		0,4	65	0,15		
	3/8		22	12	17															
			6	55															65	120
			6	55															65	120

other design on request

Relief-Valve, springloaded

for steam, gases and liquids in closed completion

Typ 5

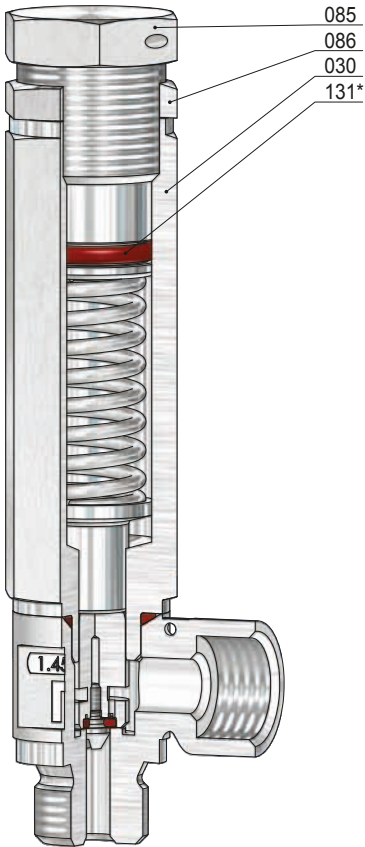

head C
only type 5.2
> 120 [bar(g)]

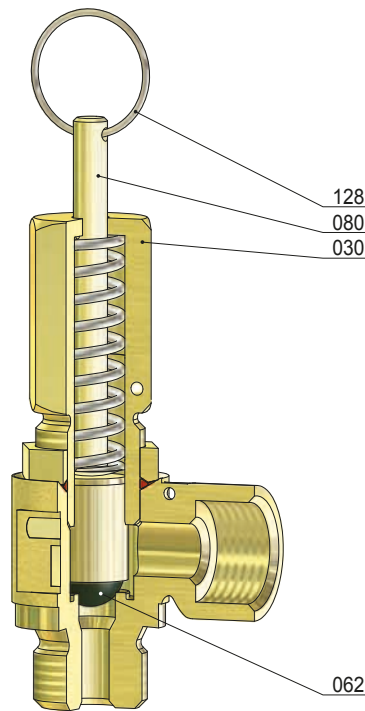

head D
only type 5.3
disc with ball
< 2 [bar(g)]

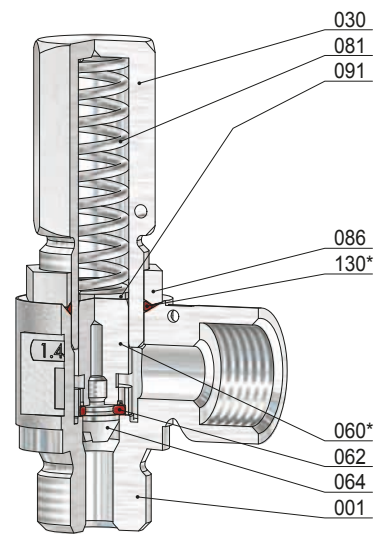

head C
disc with o-ring
> 2 [bar(g)]

Item.	Piece	Description	Item	Piece	Description
001	1	inlet body	128	1	lifting ring
030	1	spring bonnet	130 *	1	o-ring
060 *	1	disc, complete	131 *	1	o-ring
062	1	soft sealing (o-ring) / (ball)			
064	1	disc screw			
080	1	spindle			
081	1	spring			
085	1	adjusting screw			
086	1	lock nut			
091	1	pressure piece			

* expendable parts