

BALL VALVE 1/2" - 8"
ANSI 150
FULL BORE

Interested? Contact us:



www.jsc.no | post@jsc.no



OMV-B13-C-150

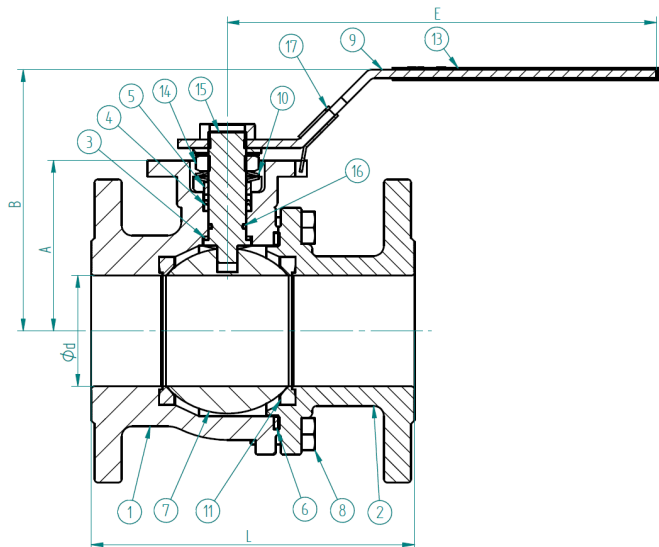
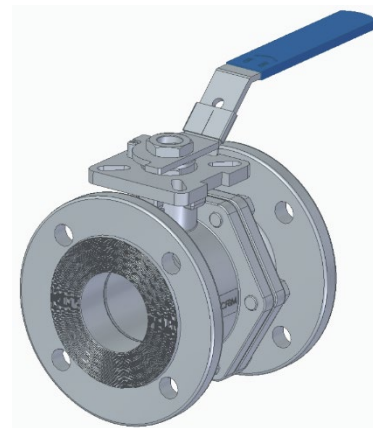

Top flange:

ISO 5211

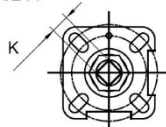

Antistatic device:

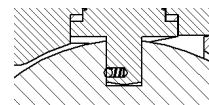

FACE TO FACE:
ANSI B16.10

CONSTRUCTION:

- floating ball
- raised face
- full bore
- solid ball
- anti-blowout
- casted

Suitable for environment temperature:

- A351 CF8M: t= -50 - +180°C

POSITION	NAME	MATERIAL
1	Body	A351 CF8M
2	Bonnet	A351 CF8M
3	Stem seal	PTFE
4	Stem packing	PTFE
5	Gland ring	AISI 316
6	Body gasket	PTFE
7	Ball	ASTM 182 F316
8	Bolt	AISI 316
9	Lever	AISI 316
10	Spring washer	AISI 301
11	Ball seat	PTFE
12	Stop pin	AISI 316
13	Lever cover	PVC
14	Stem nut	AISI 316
15	Stem	AISI 316
16	Stem O ring	FVMQ
17	Locking device	AISI 316

DN	SIZE	Ød	A	B	ISO 5211	E	K	TORQUE* [Nm]	L (ANSI B16.10)	KG
15	1/2"	15	48	82	F03/F04	117	9	5	108	1,5
20	3/4"	20	53	87	F03/F04	117	9	8	117	2,1
25	1"	25	58,5	90	F04/F05	164	11	10	127	2,85
32	1-1/4"	32	71	100	F04/F05	164	11	14	140	3,95
40	1-1/2"	40	76,5	116	F05/F07	203	14	18	165	5,95
50	2"	50	85	125	F05/F07	203	14	25	178	7,6
65	2-1/2"	65	100	154	F07/F10	255	17	48	190	13,2
80	3"	80	112,5	164	F07/F10	255	17	75	203	17,1
100	4"	100	125,5	180	F07/F10	302	17	110	229	29,2
125	5"	125	185	/	F10/F12	/	22	200	356	54
150	6"	150	203	/	F10/F12	/	22	300	394	78
200	8"	200	257	/	F12/F14	/	27	400	457	130

*Indicated is nett torque, without safety factor, recommended s.f. is 1,5.

Other materials on request.

Flat face – on customer request.