

POS	Item Number	Description
1	Body	ASTM A351 CF8M
2	Bonnet	ASTM A351 CF8M
3	Stem seal	PTFE
4	Stem packing	Graphite
5	Gland ring	AISI 316
6	Body gasket	Graphite
7	Ball	AST A182 F316
8	Bolt	AISI 316
9	Lever	AISI 316
10	Spring washer	AISI 316
11	Ball seat	RPTFE
12	Stop pin	AISI 316
13	Lever cover	PVC
14	Stem nut	AISI 316
15	Stem	AISI 316
16	Stem O-ring	FVMQ
17	Locking Device	AISI 316

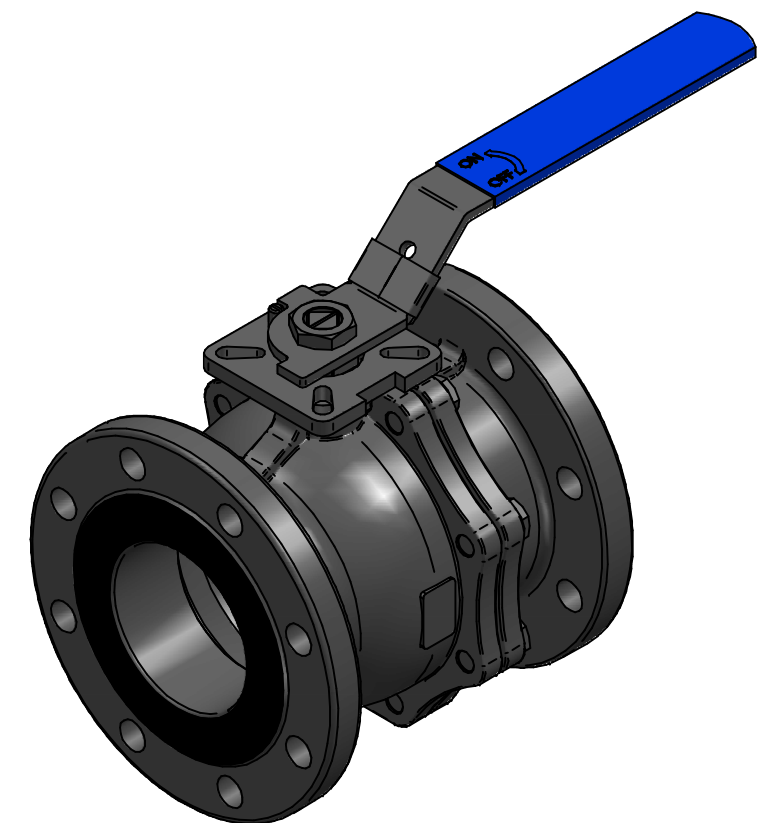

TITLE 2PC BALL VALVE FIG B13 ANSI150 4" FLANGED
F-BORE FLOATING CF8M/F316/RPTFE F07/10 SQ17
FIRESAFE A-STATIC W/HANDLE BLAS10R/BDAS320R

	NAME	DATE	SIZE	DWG NO
DRAWN	RAGA	29.08.2024	A3	OMV-100-B13C-0100FS
CHECKED	TOCO	dd.mm.yyyy	FILE NAME: OMV-100-B13C-0100FS.dft	
ENG APPR	TOCO	dd.mm.yyyy	SCALE: 1:3	REV: 00
MGR APPR	TOCO	dd.mm.yyyy	WEIGHT: 29.2 kg	SHEET: 1 OF 1

UNLESS OTHERWISE SPECIFIED
DIMENSIONS ARE IN MILLIMETERS
AND TOLERANCES ARE +/-0,5

REV	DESCRIPTION	DATE	APPROVED
REVISION HISTORY			