

DETAIL A

POS	Item Number	Description
1	Body	ASTM A351 CF8M
2	Body cover	ASTM A182 F316
3	Stem seal	PTFE
4	Stem packing	Graphite
5	Gland ring	SS316
6	Body gasket	Graphite
7	Ball	AST A182 F316
8	Thrust washer	Graphite
9	Bolt	SS316
10	Lever	SS316
11	Spring washer	SS316
12	Ball seat	PEEK/RPTFE
13	Stop pin	SS316
14	Lever cover	PVC
15	Stem nut	SS316
16	Stem	ASTM A182 F316

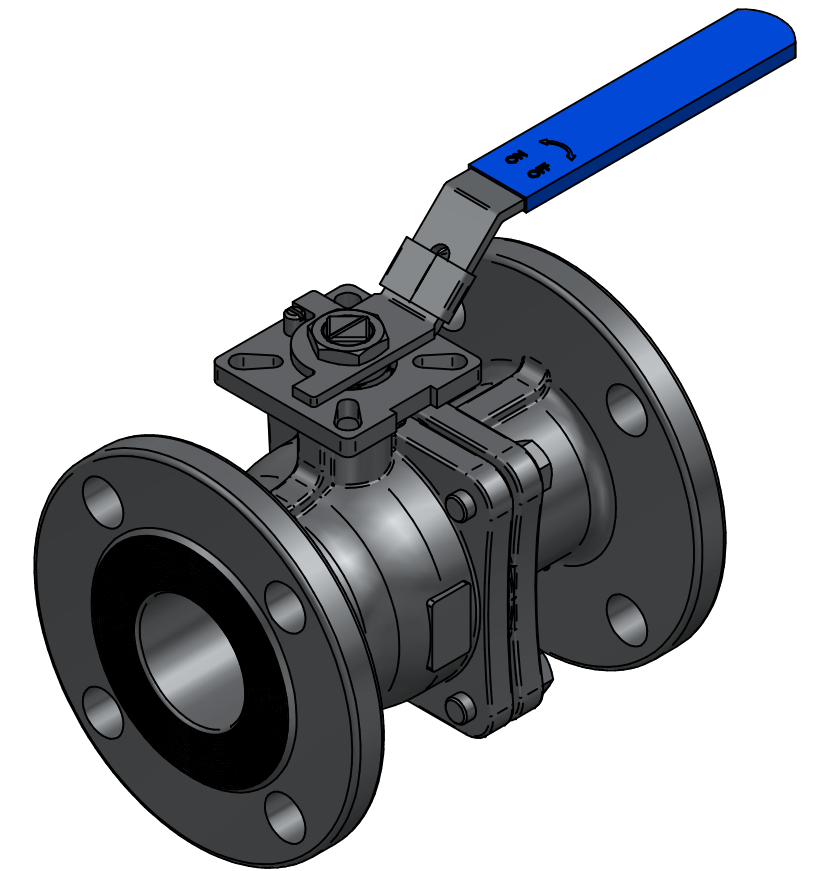

		NAME	DATE	SIZE	DWG NO
DRAWN	EMLA	20.04.2023	A3	OMV-100-B13-0050	
CHECKED	TOCO	dd.mm.yyyy	FILE NAME: OMV-100-B13-0050.dft		
ENG APPR	TOCO	dd.mm.yyyy	SCALE: 1:2	REV: 01	
MGR APPR	TOCO	dd.mm.yyyy	WEIGHT: 7.6kg	SHEET: 1 OF 1	

TITLE BALL VALVE FIG B13, 2" ANSI, FB, FLOATING BALL

UNLESS OTHERWISE SPECIFIED DIMENSIONS ARE IN MILLIMETERS AND TOLERANCES ARE +/-0,5

REV	DESCRIPTION	DATE	APPROVED
01	REVISED TO SHOW ISO-TOP	20.04.2023	JOBE
00	ISSUED	23.03.2023	MOTO
REVISION HISTORY			