

KUNKLE SERIES 900 SAFETY RELIEF VALVES

SAFETY AND RELIEF PRODUCTS

MODELS 912, 913, 918 AND 919 OVERVIEW

Model 912: Full nozzle design. SS warn ring and disc with brass/bronze base. Bronze/brass body and bonnet.

Model 913: Full nozzle design. Bronze/brass body and bonnet. 316 SS trim (base, disc and disc holder).

Model 918: As Model 912 except resilient seat/seal. Superior 'leak-free' performance. FM approved with 316 SS base for fire pump installations in 'BDD' and 'BDE' sizes².

Model 919: As Model 913 except resilient seat/seal. Superior 'leak-free' performance. Bronze body and bonnet. 316 SS trim (base, disc and disc holder).

Code: ASME VIII and XIII, PED and PE(S)R



PRESSURE AND TEMPERATURE LIMITS

Pressure limits

Models 912, 913, 918, 919: See specification table on page 9 (except vacuum service)

Vacuum: 6" to 29" HG (200 to 1000 mbarg)

Temperature limits

Model 912^[3]: -320/406°F (-195/208°C)

Model 913^[3]: -320/425°F (-195/219°C)

Models 918 and 919: Temperatures limited by elastomer seat material. See 'Service Recommendations for Resilient Seat/Seal Materials' (page 9).

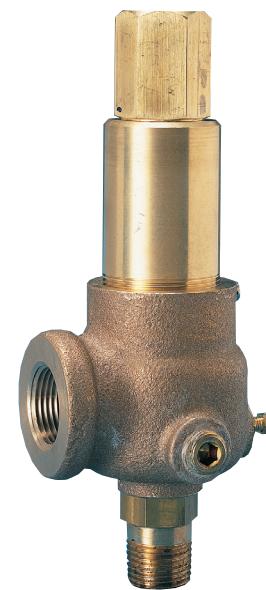

MODEL 912

OPTIONS

- Threaded cap^[4,5].
- Threaded cap with gag^[4,5].
- Plain lever.
- Plain lever with gag.
- Plain lever with vibration dampener.
- Packed lever^[4,5].
- Packed lever with gag^[4,5].
- Models 913 and 919 available with 150#, 300# and 600# inlet flanges and 150# and 300# outlet flanges per ANSI B16.5 (see page 4 for applicable parts and materials information).
- Models 913 and 919 available with Tri-clover adapter inlet (see page 5 for applicable parts and materials information).

FLANGE CONFIGURATIONS

Model	Inlet	Orifice	Outlet
9*DC	1/2"	D	3/4"
9*DC*3	1/2"	D	1"
9*DD	3/4"	D	3/4"
9*DD*3	3/4"	D	1"
9*DE*3	1"	D	1"
9*ED	3/4"	E	1 1/4"
9*FE	1"	F	1 1/2"
9*GF	1 1/4"	G	2"
9*HG	1 1/2"	H	2 1/2"
9*JH	2"	J	3"

TRI-CLOVER CONFIGURATIONS

Model	Inlet	Orifice	Outlet
9*ZDE*3	1"	D	1"
9*ZEE	1"	E	1 1/4"
9*ZFG	1 1/2"	F	1 1/2"
9*ZGG	1 1/2"	G	2"
9*ZGH	2"	G	2"
9*ZHH	2"	H	2 1/2"
9*ZJJ	2 1/2"	J	3"

NOTES

1. ASME standard valves for air, steam and hot water above 140°F (60°C) must have lift lever.
2. Requires variations listed below for adjustable relief pressure settings:
Variation 10: 60 - 125 psig (4.1 - 8.6 barg)
Variation 11: 126 - 175 psig (8.7 - 12 barg)
Variation 12: 176 - 250 psig (12.1 - 17.2 barg)
3. For vacuum service: Temperature range is -30/250°F (-34/121°C).
4. Maximum back pressure 50 psig (3.4 barg).
5. Back pressure increases set pressure on a one to one basis, and reduces capacity. Back pressure in excess of 10% of set pressure is not recommended.

KUNKLE SERIES 900 SAFETY RELIEF VALVES

SAFETY AND RELIEF PRODUCTS

Specifications - Models 912, 913, 918, and 919

SERVICE RECOMMENDATIONS FOR RESILIENT SEAT/SEAL MATERIALS

Seat/seal materials	Service recommendation
Buna-N (NBR) [-30 to 250°F] [-34 to 121°C]	Air, anhydrous ammonia, butane, carbon dioxide, diesel oil, ethyl chloride, ethyl ether, freons #11 and 12, fuel oil, gasoline, helium, hydrogen sulphide, kerosene, lube oil, natural gas, nitrogen, oxygen (gas), propane, propylene, sulphur dioxide, vinyl chloride
Viton A (FKM) O-ring seat: [-10 to 406°F] [-23 to 208°C] Molded seat: [-10 to 290°F] [-23 to 143°C]	Acetone, air, amyl alcohol, aniline, benzene, butane, carbon disulphide, carbon tetrachloride dowtherm A and J, ethyl chloride, ethylene, ethylene glycol, ethyl alcohol, gasoline, hexane, hydrogen sulphide, isobutyl alcohol, JP - 4 fuel, JP - 5 fuel, kerosene, lube oil, natural gas, naphtha, nitrogen, propane, propylene, propyl alcohol, sulphur dioxide, toluene, trichloroethylene, turpentine, water, xylene
Silicone [-100 to 406°F] [-73 to 208°C]	Air, helium, nitrogen, oxygen (gas)
Ethylene propylene [-70 to 400°F] [-57 to 205°C]	Steam, hot water
Neoprene [-45 to 300°F] [-43 to 149°C]	Air, anhydrous ammonia, butane, butyl alcohol, castor oil, denatured alcohol, ethanol, ethyl alcohol, freons (12, 13, 14 and 22), glycols, natural gas and silicate esters
Kalrez® 7390 [-15 to 608°F] [-26 to 320°C]	Aliphatic and aromatic hydrocarbons, chlorinated hydrocarbons, polar solvents (ketones, esters, ethers), inorganic and organic acids, water, and steam (steam service up to 380°F [193°C] / 200 psig saturated)
Aflas® [15 to 450°F] [-9 to 232°C]	Bases, phosphate esters, amines, engine oils, pulp and paper liquors, hot water, and steam (steam service up to 360°F [182°C] / 150 psig saturated)
HNBR [-55° to 300°F] [-48 to 150°C]	Aliphatic hydrocarbons, vegetable and animal fats and oils, HFA and HFB and HFC hydraulic fluids, dilute acids and bases and salt solutions at moderate temperatures, ozone aging and weathering, water, and steam (steam service up to 300°F [148°C] / 50 psig saturated)

NOTE

- These recommendations are a guide only. For the final selection of the proper material, your experience with available elastomers of various lading fluids should be considered.

SPECIFICATIONS

Model ² number	Orifice	Connections ANSI Standard		Maximum set pressure psig (barg)		Dimensions, in (mm)					Approx. Weight lb (kg)
		Inlet	Outlet	912-918 ^{4,10}	913-919 ^{5,10}	A	B	C Plain lever	C Threaded cap	C Packed lever	
9*BDC	D	1/2" [12.7]	3/4" [19.0]	300 [20.7]	1400 [96.5]	2 3/8 [60]	1 5/8 [41]	8 3/8 [213]	7 1/4 [184]	9 [229]	3 [1.4]
9*BDC*3	D	1/2" [12.7]	1" [25.4]	300 [20.7]	1400 [96.5]	2 3/8 [60]	1 5/8 [41]	8 3/8 [213]	7 1/4 [184]	9 [229]	3 [1.4]
9*BDD ³	D	3/4" [19.0]	3/4" [19.0]	-	1400 [96.5]	2 3/8 [60]	1 5/8 [41]	8 3/8 [213]	7 1/4 [184]	9 [229]	3 [1.4]
9*BDD*3 ³	D	3/4" [19.0]	1" [25.4]	-	1400 [96.5]	2 3/8 [60]	1 5/8 [41]	8 3/8 [213]	7 1/4 [184]	9 [229]	3 [1.4]
9*BDE*3 ³	D	1" [25.4]	1" [25.4]	-	1400 [96.5]	2 3/8 [67]	1 5/8 [41]	8 3/8 [219]	7 1/2 [191]	9 3/8 [232]	3 [1.4]
9*BED	E	3/4" [19.0]	1 1/4" [31.8]	300 [20.7]	1000 [68.9] ⁷	2 5/8 [67]	2 [51]	8 3/4 [222]	7 5/8 [194]	9 3/8 [238]	4 [1.8]
9*BEF ^{3,11}	E	1 1/4" [31.8]	1 1/4" [31.8]	-	1000 [68.9] ⁷	3 [76]	2 [51]	9 1/8 [232]	8 [203]	9 3/4 [248]	4 [1.8]
9*BFE	F	1" [25.4]	1 1/2" [38.1]	300 [20.7]	700 [48.3] ⁸	2 7/8 [73]	2 3/8 [60]	9 7/8 [251]	8 3/4 [222]	10 1/2 [267]	6 [2.7]
9*BFG ^{3,11}	F	1 1/2" [38.1]	1 1/2" [38.1]	-	700 [48.3] ⁸	3 [76]	2 3/8 [60]	10 [254]	8 7/8 [225]	10 5/8 [270]	6 [2.7]
9*BGF	G	1 1/4" [31.8]	2" [50.8]	300 [20.7]	600 [41.4]	3 1/4 [83]	2 5/8 [67]	11 1/4 [286]	10 1/8 [257]	11 3/4 [298]	8 [3.6]
9*BGH ^{3,11}	G	2" [50.8]	2" [50.8]	-	600 [41.4]	3 1/4 [83]	2 5/8 [67]	11 1/4 [286]	10 1/8 [257]	11 3/4 [298]	8 [3.6]
9*BHG	H	1 1/2" [38.1]	2 1/2" [63.5]	300 [20.7]	500 [34.5]	3 1/2 [89]	2 3/4 [70]	13 [330]	11 1/8 [283]	12 1/2 [318]	11 [5.0]
9*BJH	J ⁶	2" [50.8]	3" [76.2]	300 [20.7]	500 [34.5] ⁹	4 [102]	3 1/4 [83]	14 1/2 [368]	12 1/2 [318]	15 1/8 [384]	15 [6.8]

Dimensions are for reference only.

NOTES

- Maximum temperature controlled by resilient seat/seal material.
- Replace asterisk with desired model number. Data applicable to all models.
- Available with SS trim (models 913 and 919) only.
- Maximum pressure on steam is 250 psig.
- Maximum pressure on steam is 300 psig.
- For C dimensions: pressures above 200 psig (14 barg) add 1.25" (31.8 mm) to the overall height.
- 900 psig for liquid service or high temp alloy spring.
- 600 psig for liquid service or high temp alloy spring.
- 367 [25.3] for plain lever with gag.
- Maximum back pressure 50 psig (3.4 barg).
- Not available with flanges.

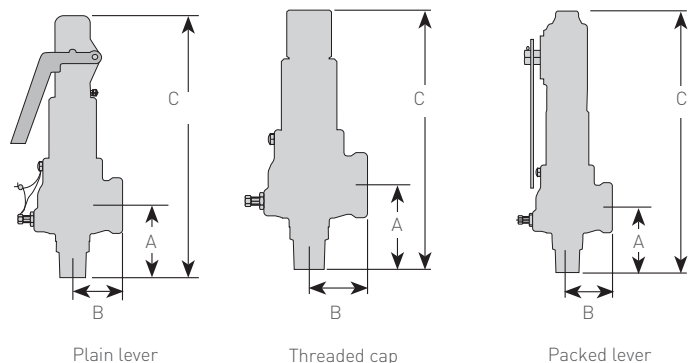

KUNKLE SERIES 900 SAFETY RELIEF VALVES

SAFETY AND RELIEF PRODUCTS

Specifications - Models 912, 913, 918, and 919 (continued)

PARTS AND MATERIALS - MODELS 912, 913, 918, 919 THREADED CAP

No.	Part name	Materials
1	Nozzle ^[2]	Brass, B21 or B283 Alloy 485, [SS, SA479-316 ⁵ Models 913, 919 only]
2	O-ring body ^[6]	PTFE
3	Body	Bronze, B584 Alloy 84400
4	Warn ring	SS, A743-CF8M
5	Disc	SS, A479-316
6	Set screw nut	SS 18-8
7	Set screw	Brass, B16
8	Seal	PTFE
9	Retainer ring	SS, A313-316
10	Disc holder	Brass, B16, [SS A351-CF8M Models 913, 919 only]
11	Guide ^[3]	Brass, B16
12	Bonnet O-ring ^[6]	PTFE
13	Screw	SS, commercial 18-8
14	Coiled spring pin	SS, A313-302
15	Spring	SS: A313-316 or A313-T631/Alloy steel: A681-H12 or B637-X750
16	Bonnet ^[4]	Brass, B16-H02
17	Spring step	SS, SA479-316
18	Stem	Brass, B16
19	Wire and seal	SS wire and lead seal, commercial
20	Cap	Brass, B16
21	Compression screw	Brass, B16
22	Jam nut	SS 18-8 or Brass, B16
23	Cap O-ring ^[6,9]	
24	Body plug ^[11]	Brass, B16 [1/4" - 18 NPT]
25 ⁷	Gag screw	Steel A108-1018/zinc plated
26 ⁸	Gag screw plug	SS 18-8
27 ⁸	Gag screw gasket	PTFE

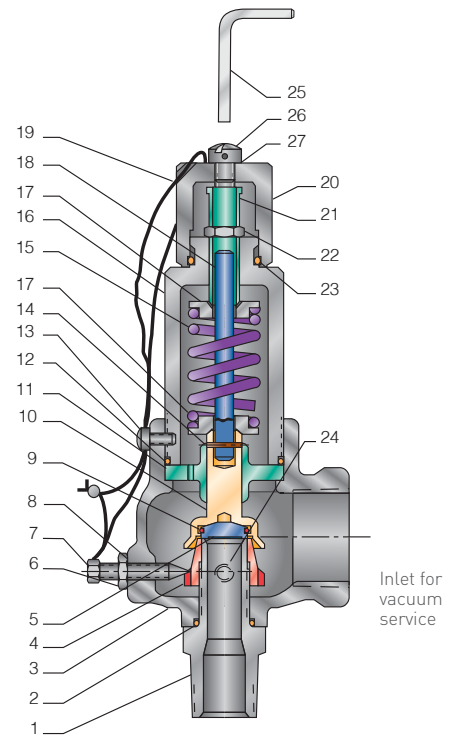

METAL SEAT
Threaded cap option (shown with gag option)

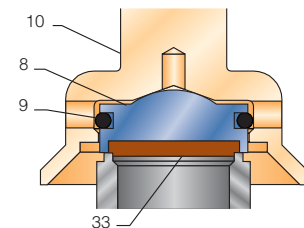

SOFT SEAT F TO J ORIFICE

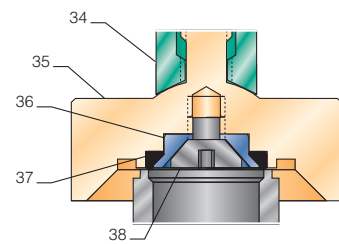

SOFT SEAT D AND E ORIFICE

PARTS AND MATERIALS - MODELS 918 AND 919 SOFT SEAT, F TO J ORIFICE

No.	Part name	918	919
8	Disc	SS A479-316	SS A479-316
9	Ring, retainer	SS A313-316	SS A313-316
10	Disc holder	Brass, B16	SS A351-CF8M
33	Molded seat ^[11]		

PARTS AND MATERIALS - MODELS 918 AND 919 SOFT SEAT, D AND E ORIFICE

No.	Part name	918	919
34	Spindle	Brass, B16	SS A479-316
35	Disc holder	Brass, B16	SS A479-316
36	Retainer	Brass, B16	SS A479-316
37	O-ring seat ^[10]		
38	Seat retainer screw	SS 18-8	SS 18-8

NOTES

- Material Letter designation B584, Alloy 84400.
 - Buna-N (NBR) - B
 - Ethylene propylene (EPR/EPDM) - E
 - Neoprene - N
 - Silicone - S
 - Viton® A (FKM) - V
- F through J orifice nozzle material is bronze, B62.
- G through J orifice guide material is brass, B283, Alloy 37700.
- F through J orifice bonnet material is bronze,
 - 'F' orifice (1" NPT inlet), 'G' orifice (1.25" NPT and BSPT inlet), 'H' orifice (1.5" NPT and BSPT inlet), 'J' orifice (2" NPT and BSPT inlet) nozzle material is SS, SA351-CF8M.
 - For threaded cap and packed lever only.
 - Gag screw ships with valve, not installed.
 - For threaded cap and packed lever gag options only.
 - Valve with metal seat - cap O-ring material: Buna-N (NBR) unless valve service specified is steam (designators 'L' or 'P') then O-ring material EPDM.
 - Valve with soft seat - cap O-ring material: same as seat material.

- Material Letter designation
 - Buna-N (NBR) - B
 - Ethylene propylene (EPR/EPDM) - E
 - Neoprene - N
 - Silicone - S
 - Viton® A (FKM) - V
 - Kalrez® 7390 - K
 - Aflas® - A
 - HNBR - H
- Not present for plain lever variations, except variation 12 - Plain lever with drain plug [913BDDM with 3/4" outlet only].

KUNKLE SERIES 900 SAFETY RELIEF VALVES

SAFETY AND RELIEF PRODUCTS

Specifications - Models 912, 913, 918, and 919 (continued)

PARTS AND MATERIALS - MODEL 912 PACKED LEVER

No.	Part name	Materials
18	Cap O-ring ^[1]	
19	Jam nut	Brass, B16
20	Lift cam	SS, A743 CF8M
21	Cotter pin	Steel, Commercial
22	Lever	Zinc plated steel, A108
23	Drive screw	SS, Commercial
24	Retainer nut	Brass, B16
25	Retainer O-ring ^[1]	
26	Lift cam O-ring ^[1]	
27	Cap	Bronze, B584 Alloy 84400
28	Lift nut	SS, A479 316
29	Lift washer	SS, A479 316
30	Stem	Brass, B16
31	Compression screw	Brass, B16
32 ^[2]	Gag screw	Steel A108-1018/Zinc plated
33 ^[3]	Gag screw plug	SS 18-8
34 ^[3]	Gag screw gasket	PTFE

PARTS AND MATERIALS - MODEL 912 PLAIN LEVER

No.	Part name	Materials
13	Jam nut	Brass, B16
14	Compression screw	Brass, B16
15	Lever	Steel, A109 with coating ^[1]
16	Cap	Aluminum, anodized
17	Lift nut	SS, A479-316
18	Lift washer	SS, A479-316
19	Rivet	Steel, commercial
20	Screw	SS, commercial Gr. 18-8
21	Spring step	Brass, B16
22 ^[2]	Gag screw	Steel A108-1018/Zinc plated
23 ^[4]	Vibration Dampening spring	Phosphor BRZ 510

PARTS AND MATERIALS - FLANGED OPTION (MODEL 913 AND 919)

No.	Part name	Materials
1	Inlet flange	SS, A182-F316
2	Inlet stub end	SS, A479-316
3	Outlet flange	SS, A182-F316
4	Outlet stub end	SS, A479-316

PARTS AND MATERIALS - TRI-CLOVER INLET OPTION

No.	Part name	Materials
1	Nozzle	SS A479-316

NOTES

- Valve with metal seat - O-ring material:
Buna-N (NBR) unless valve service specified is steam (designators 'L' or 'P') then O-ring material EPDM.
Valve with soft seat - O-ring material:
same as seat material
- Gag screw ships with valve, not installed.
- For threaded cap and packed lever gag options only.
- For plain lever with vibration dampener option only.

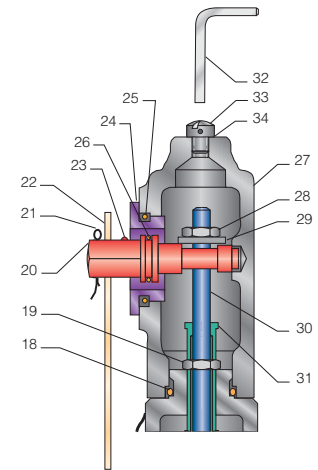

PACKED LEVER
(shown with gag option)

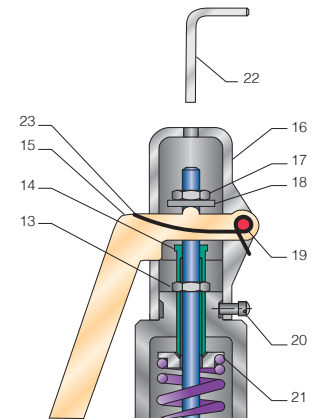

PLAIN LEVER
(shown with gag and vibration dampening spring options)

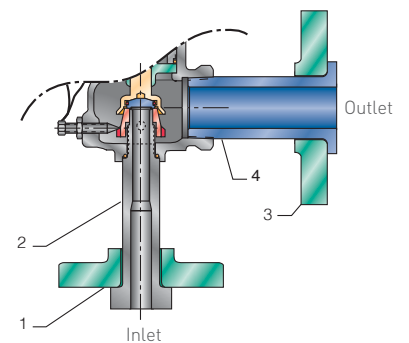

FLANGED OPTION

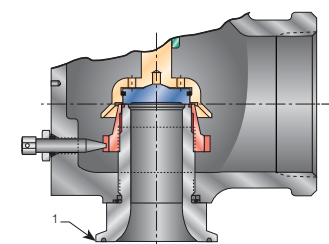

TRI-CLOVER (INLET ONLY)

KUNKLE SERIES 900 SAFETY RELIEF VALVES

SAFETY AND RELIEF PRODUCTS

SELECTION GUIDE

Example:		912	B	J	H	M	01	-	K	E	0300	
Model												
912, 913, 918, 919												
Connection type												
B	Male x female NPT											
E	CL150 flange x FNPT (Models 913 and 919 only)											
F	CL150 flange x FBSPT (Models 913 and 919 only)											
G	CL300 flange x FNPT (Models 913 and 919 only)											
H	CL300 flange x FBSPT (Models 913 and 919 only)											
J	CL150 flange x CL150 flange (Models 913 and 919 only)											
L	CL300 flange x CL150 flange (Models 913 and 919 only)											
M	CL300 flange x CL300 flange (Models 913 and 919 only)											
N	CL600 flange x CL150 flange (Models 913 and 919 only)											
P	CL600 flange x CL300 flange (Models 913 and 919 only)											
T	CL600 flange x FNPT (Models 913 and 919 only)											
V	CL600 flange x FBSPT (Models 913 and 919 only)											
W	Male x female BSPT											
Z	Tri-clover inlet x FNPT (Models 913 and 919 only)											
Orifice												
D, E, F, G, H, J												
Inlet size												
C	½" (15 mm)	F	1¼" (32 mm)	J¹⁾	2 ½" (63.5 mm)							
D	¾" (18 mm)	G	1½" (40 mm)									
E	1" (25 mm)	H	2" (50 mm)									
Seat/seal material												
M	Metal-to-metal		S	Silicone		K	Kalrez® 7390					
B	Buna-N (NBR)		V	Viton® A (FKM)		A	Aflas®					
E	EPR		N	Neoprene		H	HNBR					
Variation												
Number provided only by manufacturer to cover specific feature or option												
01	Threaded cap					31	Threaded cap 'D' orifice 1" outlet					
02	Threaded cap with gag					32	Threaded cap with gag 'D' orifice 1" outlet					
03	Plain lever					33	Plain lever 'D' orifice 1" outlet					
04	Plain lever with gag					34	Plain lever with gag 'D' orifice 1" outlet					
05	Plain lever with vibration dampener					35	Plain lever with vibration dampener 'D' orifice 1" outlet					
06	Packed lever					36	Packed lever 'D' orifice 1" outlet					
07	Packed lever with gag					37	Packed lever with gag 'D' orifice 1" outlet					
12	Plain lever with drain plug (913 BDDM with ¾" outlet only)											
Design revision												
		Orifice size										
Models	D	E	F	G	H	J						
912	-	-	-	-	-	-						
913	-	-	-	-	-	-						
918	B	B	-	-	-	-						
919	B	B	-	-	-	-						
Valve service												
J	Liquid ASME Section VIII and Section XIII (standard cap/packed lever only)											
K	Air/gas ASME Section VIII and Section XIII (plain lever/packed lever required for air)											
L	Steam ASME Section VIII and Section XIII (plain lever/packed lever required)											
M	Non-code liquid (standard cap/packed lever only)											
N	Non-code air gas											
P	Non-code steam											
Q	Vacuum (standard cap/packed lever only)											
Spring material												
E	SST											
F	Alloy steel (high temperature)											
Set pressure												
3 psig (0.2 barg) (0003) to 1400 psig (96.5 barg) (1400)												
Vacuum 6" HG (200 mbarg) (0006) to 29" HG (1000 mbarg) (0029)												

NOTE

1. Only available for Tri-clover connection.

KUNKLE SERIES 900 SAFETY RELIEF VALVES

SAFETY AND RELIEF PRODUCTS

Capacities - Models 920, 921 and 927

ASME SECTION I STEAM (U.S., lb/h) - FLOW COEFFICIENT = 0.878

Set pressure (psig)	Orifice area, in ²					
	D (0.1213)	E (0.2157)	F (0.3369)	G (0.553)	H (0.864)	J (1.415)
15	174	309	483	793	1238	2028
25	229	407	635	1043	1629	2668
35	284	504	788	1293	2020	3308
45	338	602	940	1543	2410	3948
55	393	699	1092	1793	2801	4588
65	448	797	1245	2043	3192	5227
75	504	897	1401	2299	3592	5883
85	561	997	1558	2557	3995	6542
95	617	1098	1715	2814	4397	7201
100	646	1148	1793	2943	4598	7531
125	787	1399	2185	3587	5604	9178
150	928	1650	2578	4231	6610	10826
175	1069	1901	2970	4875	7616	12473
200	1211	2153	3362	5519	8622	14121
225	1352	2404	3754	6162	9628	15768
250	1493	2655	4147	6806	10634	17416
275	1634	2906	4539	7450	11640	19063
300	1775	3157	4931	8094	12646	20711
325	1917	3408	5323	8738	13652	22359
350	2058	3659	5716	9382	14658	24006
375	2199	3911	6108	10026	15664	25654
400	2340	4162	6500	10670	16670	27301
425	2482	4413	6892	11314	17676	28949
450	2623	4664	7285	11957	18682	30596
475	2764	4915	7677	12601	19688	32244
500	2905	5166	8069	13245	20694	33891
525	3047	5417	8462	13889	-	-
550	3188	5669	8854	14533	-	-
575	3329	5920	9246	15177	-	-
600	3470	6171	9638	15821	-	-
625	3611	6422	10031	-	-	-
650	3753	6673	10423	-	-	-
675	3894	6924	10815	-	-	-
700	4035	7176	11207	-	-	-
725	4176	7427	-	-	-	-
750	4318	7678	-	-	-	-
775	4459	7929	-	-	-	-
800	4600	8180	-	-	-	-
825	4741	8431	-	-	-	-
850	4883	8682	-	-	-	-
875	5024	8934	-	-	-	-
900	5165	9185	-	-	-	-
925	5306	9436	-	-	-	-
950	5448	9687	-	-	-	-
975	5589	9938	-	-	-	-
1000	5730	10189	-	-	-	-
1050	6012	-	-	-	-	-
1100	6295	-	-	-	-	-
1200	6860	-	-	-	-	-
1300	7425	-	-	-	-	-
1400	7990	-	-	-	-	-

NOTE

1. See specifications table (page 3) for pressure and temperature limitations.

KUNKLE SERIES 900 SAFETY RELIEF VALVES

SAFETY AND RELIEF PRODUCTS

Capacities - Models 920, 921 and 927 (continued)

ASME SECTION I STEAM (Metric, kg/h) - Flow coefficient = 0.878

Set pressure (barg)	Orifice area, cm ²					
	D (0.782)	E (1.392)	F (2.174)	G (3.568)	H (5.574)	J (9.129)
1.1	81	144	226	370	578	947
2.0	114	202	316	518	810	1326
3.0	150	266	416	683	1066	1747
4.0	186	330	516	847	1323	2167
5.0	222	395	617	1014	1583	2593
6.0	259	461	721	1183	1848	3027
7.0	297	527	824	1352	2113	3460
8.0	334	594	927	1522	2377	3894
9.0	371	660	1030	1691	2642	4327
10.0	408	726	1133	1860	2907	4761
12.0	482	858	1340	2199	3436	5627
14.0	557	990	1546	2538	3965	6494
16.0	631	1122	1753	2877	4495	7361
18.0	705	1254	1959	3216	5024	8228
20.0	780	1386	2165	3554	5553	9095
22.0	854	1519	2372	3893	6082	9962
24.0	928	1651	2578	4232	6612	10828
26.0	1003	1783	2785	4571	7141	11695
28.0	1077	1915	2991	4909	7670	12562
30.0	1151	2047	3197	5248	8200	13429
32.0	1226	2179	3404	5587	8729	14296
34.0	1300	2311	3610	5926	9258	15163
36.0	1374	2444	3816	6265	-	-
38.0	1448	2576	4023	6603	-	-
40.0	1523	2708	4229	6942	-	-
42.0	1597	2840	4436	-	-	-
44.0	1671	2972	4642	-	-	-
46.0	1746	3104	4848	-	-	-
48.0	1820	3236	5055	-	-	-
50.0	1894	3368	-	-	-	-
52.0	1969	3501	-	-	-	-
54.0	2043	3633	-	-	-	-
56.0	2117	3765	-	-	-	-
58.0	2192	3897	-	-	-	-
60.0	2266	4029	-	-	-	-
62.0	2340	4161	-	-	-	-
64.0	2415	4293	-	-	-	-
66.0	2489	4426	-	-	-	-
68.0	2563	4558	-	-	-	-
70.0	2637	-	-	-	-	-
72.0	2712	-	-	-	-	-
76.0	2860	-	-	-	-	-
80.0	3009	-	-	-	-	-
84.0	3158	-	-	-	-	-
88.0	3306	-	-	-	-	-
92.0	3455	-	-	-	-	-
96.0	3604	-	-	-	-	-

NOTE

1. See specifications table (page 3) for pressure and temperature limitations.

KUNKLE SERIES 900 SAFETY RELIEF VALVES

SAFETY AND RELIEF PRODUCTS

Capacities - Models 910, 911, 912, 913, 916, 917, 918 and 919

NON-CODE⁽¹⁾ AND ASME SECTION VIII AND SECTION XIII AIR (U.S., SCFM) - Flow coefficient = 0.878

Set pressure (psig)	Orifice area, in ²					
	D (0.1213)	E (0.2157)	F (0.3369)	G (0.553)	H (0.864)	J (1.415)
3	28	50	77	127	198	325
4	32	57	89	146	228	374
5	36	64	99	163	255	417
6	39	70	109	178	278	456
7	42	75	117	192	300	491
8	45	80	125	205	320	524
9	48	85	132	217	338	554
10	50	89	139	228	356	583
11	52	93	145	238	372	610
12	54	97	151	248	388	635
13	57	101	157	258	403	660
14	59	104	163	267	417	683
15	64	114	177	291	455	745
25	83	148	232	380	594	972
35	104	185	288	474	740	1212
45	125	223	348	571	893	1462
55	147	261	408	669	1046	1713
65	168	299	467	767	1199	1963
75	190	337	527	865	1352	2214
85	211	376	587	963	1505	2464
95	233	414	646	1061	1658	2715
100	243	433	676	1110	1734	2840
125	297	528	825	1355	2116	3466
150	351	624	974	1599	2499	4093
175	405	719	1124	1844	2881	4719
200	458	815	1273	2089	3264	5345
225	512	910	1422	2334	3646	5971
250	566	1006	1571	2578	4029	6598
275	619	1101	1720	2823	4411	7224
300	673	1197	1869	3068	4793	7850
325	727	1292	2018	3313	5176	8477
350	780	1388	2167	3558	5558	9103
375	834	1483	2316	3802	5941	9729
400	888	1579	2466	4047	6323	10355
425	941	1674	2615	4292	6705	10982
450	995	1769	2764	4537	7088	11608
475	1049	1865	2913	4781	7470	12234
500	1102	1960	3062	5026	7853	12861
600	1317	2342	3658	6005	-	-
700	1532	2724	4255	-	-	-
800	1747	3106	-	-	-	-
900	1957	3489	-	-	-	-
1000	2176	3870	-	-	-	-
1100	2391	-	-	-	-	-
1200	2606	-	-	-	-	-
1300	2820	-	-	-	-	-
1400	3035	-	-	-	-	-

NOTES

1. No code stamp or 'NB' on nameplate below 15 psig set.
2. See specifications table (pages 3 and 9) for pressure and temperature limitations.

KUNKLE SERIES 900 SAFETY RELIEF VALVES

SAFETY AND RELIEF PRODUCTS

Capacities - Models 910, 911, 912, 913, 916, 917, 918 and 919 (continued)

NON-CODE⁽¹⁾ AND ASME SECTION VIII AND SECTION XIII AIR (Metric, Nm³/h) - Flow coefficient = 0.878

Set pressure (barg)	Orifice area, cm ²					
	D (0.782)	E (1.392)	F (2.174)	G (3.568)	H (5.574)	J (9.129)
0.2	45	80	126	206	322	528
0.5	71	126	196	323	504	825
1.0	98	175	273	448	700	1147
2.0	151	268	419	687	1074	1758
3.0	202	359	561	920	1438	2355
4.0	253	451	704	1155	1805	2956
5.0	305	542	847	1390	2172	3557
6.0	356	634	990	1625	2538	4157
7.0	408	725	1133	1860	2905	4758
8.0	459	817	1276	2094	3272	5359
9.0	511	908	1419	1329	3639	5960
10.0	562	1000	1562	2564	4006	6560
12.0	665	1183	1848	3033	4739	7762
14.0	768	1366	2134	3503	5473	8963
16.0	871	1549	2420	3972	6206	10165
18.0	974	1733	2706	4442	6940	11366
20.0	1077	1916	2992	4911	7673	12567
22.0	1180	2099	3278	5381	8407	13769
24.0	1283	2282	3564	5851	9141	14970
26.0	1386	2465	3850	6320	9874	16172
28.0	1489	2648	4136	6790	10608	17373
30.0	1592	2831	4422	7259	11341	18574
32.0	1695	3015	4708	7729	12075	19776
34.0	1798	3198	4994	8198	12808	20977
36.0	1901	3381	5280	8668	-	-
38.0	2004	3564	5567	9137	-	-
40.0	2107	3747	5853	9607	-	-
42.0	2210	3930	6139	-	-	-
44.0	2313	4113	6425	-	-	-
46.0	2416	4297	6711	-	-	-
48.0	2519	4480	6997	-	-	-
50.0	2622	4663	-	-	-	-
52.0	2725	4846	-	-	-	-
54.0	2828	5029	-	-	-	-
56.0	2931	5212	-	-	-	-
58.0	3034	5395	-	-	-	-
60.0	3137	5579	-	-	-	-
62.0	3240	5762	-	-	-	-
64.0	3345	5945	-	-	-	-
66.0	3448	6128	-	-	-	-
68.0	3551	6311	-	-	-	-
70.0	3654	-	-	-	-	-
72.0	3757	-	-	-	-	-
76.0	3963	-	-	-	-	-
80.0	4169	-	-	-	-	-
84.0	4375	-	-	-	-	-
88.0	4581	-	-	-	-	-
92.0	4788	-	-	-	-	-
96.0	4994	-	-	-	-	-

NOTES

1. No code stamp or 'NB' on nameplate below 1.1 barg set.
2. See specifications table (pages 3 and 9) for pressure and temperature limitations.

KUNKLE SERIES 900 SAFETY RELIEF VALVES

SAFETY AND RELIEF PRODUCTS

Capacities - Models 910, 911, 912, 913, 916, 917, 918 and 919 (continued)

NON-CODE⁽¹⁾ AND ASME SECTION VIII AND SECTION XIII STEAM (U.S., lb/h) - Flow coefficient = 0.878

Set pressure (psig)	Orifice area, in ²					
	D (0.1213)	E (0.2157)	F (0.3369)	G (0.553)	H (0.864)	J (1.415)
3	87	155	242	398	621	1017
4	100	178	278	456	712	1167
5	111	197	308	506	791	1295
6	121	215	336	551	861	1410
7	130	231	360	591	924	1513
8	138	245	383	628	981	1607
9	145	258	403	662	1035	1694
10	152	271	423	694	1084	1776
11	159	282	441	724	1131	1852
12	165	293	458	752	1175	1924
13	171	304	474	778	1216	1992
14	176	313	489	803	1255	2056
15	179	319	498	818	1278	2092
25	234	416	650	1068	1668	2732
35	292	519	810	1330	2078	3404
45	352	626	978	1605	2508	4108
55	412	733	1146	1880	2938	4811
65	473	841	1313	2155	3368	5515
75	533	948	1481	2430	3797	6219
85	593	1055	1648	2706	4227	6923
95	654	1163	1816	2981	4657	7627
100	684	1216	1900	3118	4872	7979
125	835	1484	2319	3806	5946	9738
150	986	1753	2737	4493	7020	11498
175	1136	2021	3156	5181	8095	13257
200	1287	2289	3575	5869	9169	15017
225	1438	2557	3994	6556	10243	16776
250	1589	2826	4413	7244	11318	18536
275	1740	3094	4832	7932	12392	20295
300	1891	3362	5251	8619	13467	22055
325	2041	3630	5670	9307	14541	23814
350	2192	3898	6089	9994	15615	25574
375	2343	4167	6508	10682	16690	27333
400	2494	4435	6927	11370	17764	29093
425	2645	4703	7346	12057	18838	30852
450	2796	4971	7765	12745	19913	32612
475	2946	5239	8183	13433	20987	34371
500	3097	5508	8602	14120	22061	36131
550	3399	6044	9440	15496	-	-
600	3701	6581	10278	16871	-	-
650	4002	7117	11116	-	-	-
700	4304	7653	11954	-	-	-
750	4606	8190	-	-	-	-
800	4907	8726	-	-	-	-
850	5209	9263	-	-	-	-
900	5511	9799	-	-	-	-
950	5812	10336	-	-	-	-
1000	6114	10872	-	-	-	-
1100	6717	-	-	-	-	-
1200	7321	-	-	-	-	-
1300	7924	-	-	-	-	-
1400	8527	-	-	-	-	-

NOTES

1. No code stamp or 'NB' on nameplate below 15 psig set.
2. See specifications table (pages 3 and 9) for pressure and temperature limitations.

KUNKLE SERIES 900 SAFETY RELIEF VALVES

SAFETY AND RELIEF PRODUCTS

Capacities - Models 910, 911, 912, 913, 916, 917, 918 and 919 (continued)

NON-CODE⁽¹⁾ AND ASME SECTION VIII AND SECTION XIII STEAM, (Metric, kg/h) - Flow coefficient = 0.878

Set pressure (barg)	Orifice area, cm ²					
	D (0.782)	E (1.392)	F (2.174)	G (3.568)	H (5.574)	J (9.129)
0.2	39	69	108	177	277	453
0.5	60	106	166	272	425	697
1.0	81	144	225	369	577	945
2.0	116	207	323	529	827	1355
3.0	156	277	432	709	1108	1815
4.0	195	347	542	890	1391	2278
5.0	235	418	653	1071	1673	2741
6.0	275	488	763	1252	1956	3204
7.0	314	559	873	1433	2239	3666
8.0	354	629	983	1614	2521	4129
9.0	394	700	1093	1795	2804	4592
10.0	433	771	1204	1976	3087	5055
12.0	513	912	1424	2337	3652	5981
14.0	592	1053	1644	2699	4217	6907
16.0	671	1194	1865	3061	4782	7832
18.0	751	1335	2085	3423	5348	8758
20.0	830	1476	2306	3785	5913	9684
22.0	910	1617	2526	4146	6478	10610
24.0	989	1758	2746	4508	7043	11535
26.0	1068	1900	2967	4870	7609	12461
28.0	1148	2041	3187	5232	8174	13387
30.0	1227	2182	3408	5594	8739	14313
32.0	1306	2323	3628	5955	9304	15238
34.0	1386	2464	3849	6317	9870	16164
36.0	1465	2605	4069	6679	-	-
38.0	1544	2746	4289	7041	-	-
40.0	1624	2887	4510	7403	-	-
42.0	1703	3029	4730	-	-	-
44.0	1783	3170	4951	-	-	-
46.0	1862	3311	5171	-	-	-
48.0	1941	3452	5391	-	-	-
50.0	2021	3593	-	-	-	-
52.0	2100	3734	-	-	-	-
54.0	2179	3875	-	-	-	-
56.0	2259	4016	-	-	-	-
58.0	2338	4157	-	-	-	-
60.0	2417	4299	-	-	-	-
62.0	2497	4440	-	-	-	-
64.0	2576	4581	-	-	-	-
66.0	2656	4722	-	-	-	-
68.0	2735	4863	-	-	-	-
70.0	2814	-	-	-	-	-
72.0	2894	-	-	-	-	-
76.0	3052	-	-	-	-	-
80.0	3211	-	-	-	-	-
84.0	3370	-	-	-	-	-
88.0	3529	-	-	-	-	-
92.0	3687	-	-	-	-	-
96.0	3846	-	-	-	-	-

NOTES

1. No code stamp or 'NB' on nameplate below 1.1 barg set.
2. See specifications table (pages 3 and 9) for pressure and temperature limitations.

KUNKLE SERIES 900 SAFETY RELIEF VALVES

SAFETY AND RELIEF PRODUCTS

Capacities - Models 910, 911, 912, 913, 916, 917, 918, 919, 928 and 929

ASME I, VIII AND XIII LIQUID (U.S., GPM) - Flow coefficient = 0.710

Set pressure (psig)	Orifice area, in ²					
	D (0.1213)	E (0.2157)	F (0.3369)	G (0.553)	H (0.864)	J (1.415)
15	14	25	39	63	99	162
25	17	31	48	79	123	202
35	20	36	56	93	145	237
45	23	41	64	105	164	269
55	26	45	71	116	181	297
65	28	49	77	126	197	323
75	30	53	83	136	212	347
85	32	56	88	144	225	369
95	34	60	93	153	238	390
100	34	61	95	156	244	400
125	38	68	107	175	273	448
150	42	75	117	192	299	490
175	45	81	126	207	323	530
200	49	86	135	221	346	566
225	52	92	143	235	367	601
250	54	97	151	247	387	633
275	57	101	158	259	405	664
300	60	106	165	271	423	694
325	62	110	172	282	441	722
350	64	114	178	293	457	749
375	67	118	185	303	473	775
400	69	122	191	313	489	801
425	71	126	197	323	504	825
450	73	129	202	332	519	849
475	75	133	208	341	533	873
500	77	136	213	350	547	895
550	81	143	224	367	-	-
600	84	150	234	383	-	-
650	88	156	-	-	-	-
700	91	161	-	-	-	-
750	94	167	-	-	-	-
800	97	173	-	-	-	-
850	100	178	-	-	-	-
900	103	183	-	-	-	-
950	106	-	-	-	-	-
1000	109	-	-	-	-	-
1050	111	-	-	-	-	-
1100	114	-	-	-	-	-
1150	116	-	-	-	-	-
1200	119	-	-	-	-	-
1250	121	-	-	-	-	-
1300	124	-	-	-	-	-
1350	126	-	-	-	-	-
1400	128	-	-	-	-	-

NOTES

1. See specifications table (pages 3 and 9) for pressure and temperature limitations.
2. Liquid conversion factors to determine liquid capacity at other than 10% accumulation, multiply by the following:
 - 1.022 = 15% accumulation
 - 1.045 = 20% accumulation
 - 1.066 = 25% accumulation [see page 21]

KUNKLE SERIES 900 SAFETY RELIEF VALVES

SAFETY AND RELIEF PRODUCTS

Capacities - Models 910, 911, 912, 913, 916, 917, 918, 919, 928 and 929 (continued)

ASME SECTION I, VIII AND XIII LIQUID, (Metric m³/h) - Flow coefficient = 0.710

Set pressure (barg)	Orifice area, cm ²					
	D (0.782)	E (1.392)	F (2.174)	G (3.568)	H (5.574)	J (9.129)
1.0	3	6	9	14	22	36
2.0	4	7	12	19	30	49
3.0	5	9	14	23	37	60
4.0	6	11	16	27	42	69
5.0	7	12	18	30	47	77
6.0	7	13	20	33	52	85
7.0	8	14	22	36	56	92
8.0	8	15	23	38	60	98
9.0	9	16	25	41	63	104
10.0	9	17	26	43	67	110
12.0	10	18	29	47	73	120
14.0	11	20	31	51	79	130
16.0	12	21	33	54	85	139
18.0	13	22	35	57	90	147
20.0	13	24	37	61	95	155
22.0	14	25	39	63	99	162
24.0	15	26	40	66	104	170
26.0	15	27	42	69	108	177
28.0	16	28	44	72	112	183
30.0	16	29	45	74	116	190
32.0	17	30	47	77	120	196
34.0	17	31	48	79	123	202
36.0	18	32	49	81	-	-
38.0	18	33	51	83	-	-
40.0	19	33	52	86	-	-
42.0	19	34	-	-	-	-
44.0	20	35	-	-	-	-
46.0	20	36	-	-	-	-
48.0	21	37	-	-	-	-
50.0	21	37	-	-	-	-
52.0	21	38	-	-	-	-
54.0	22	39	-	-	-	-
56.0	22	40	-	-	-	-
58.0	23	40	-	-	-	-
60.0	23	41	-	-	-	-
62.0	23	42	-	-	-	-
64.0	25	-	-	-	-	-
66.0	26	-	-	-	-	-
68.0	26	-	-	-	-	-
70.0	26	-	-	-	-	-
72.0	27	-	-	-	-	-
76.0	28	-	-	-	-	-
80.0	28	-	-	-	-	-
84.0	29	-	-	-	-	-
88.0	30	-	-	-	-	-
92.0	30	-	-	-	-	-
96.0	31	-	-	-	-	-

NOTE

1. See specifications table (pages 3 and 9) for pressure and temperature limitations.

KUNKLE SERIES 900 SAFETY RELIEF VALVES

SAFETY AND RELIEF PRODUCTS

Capacities - Models 910, 911, 912, 913, 916, 917, 918 and 919

NON-CODE LIQUID - 25% Accumulation (U.S., GPM) - Flow coefficient = 0.710

Set pressure (psig)	Orifice area, in ²					
	D (0.1213)	E (0.2157)	F (0.3369)	G (0.553)	H (0.864)	J (1.415)
3	6	11	18	29	45	74
4	7	13	20	33	52	85
5	8	15	23	37	58	95
6	9	16	25	41	64	105
7	10	17	27	44	69	113
8	10	18	29	47	74	121
9	11	20	30	50	78	128
10	12	21	32	53	82	135
11	12	22	34	55	86	142
12	13	23	35	58	90	148
13	13	23	37	60	94	154
14	14	24	38	62	98	160
15	14	25	39	65	101	165
25	18	33	51	83	130	213
35	22	38	60	99	154	253
45	25	44	68	112	175	286
55	27	48	75	124	193	317
65	29	52	82	134	210	344
75	32	56	88	144	226	370
85	34	60	94	154	240	394
95	36	63	99	163	254	416
100	37	65	102	167	261	427
125	41	73	114	186	291	477
150	45	80	124	204	319	523
175	48	86	134	221	345	565
200	52	92	144	236	369	604
225	55	98	152	250	391	640
250	58	103	161	264	412	675
275	61	108	169	277	432	708
300	63	113	176	289	451	739
325	66	117	183	301	470	769
350	68	122	190	312	488	799
375	71	126	197	323	505	827
400	73	130	203	334	521	854
425	75	134	210	344	537	880
450	78	138	216	354	553	905
475	80	142	221	364	568	930
500	82	145	227	373	583	954
600	90	159	249	409	-	-
700	97	172	-	-	-	-
800	103	184	-	-	-	-
900	110	195	-	-	-	-
1000	116	-	-	-	-	-
1100	121	-	-	-	-	-
1200	127	-	-	-	-	-
1300	132	-	-	-	-	-
1400	137	-	-	-	-	-

NOTE

1. See specifications table (pages 3 and 9) for pressure and temperature limitations.

KUNKLE SERIES 900 SAFETY RELIEF VALVES

SAFETY AND RELIEF PRODUCTS

Capacities - Models 910, 911, 912, 913, 916, 917, 918 and 919 (continued)

NON-CODE LIQUID - 25% Accumulation, (Metric, m³/h) Flow coefficient = 0.710

Set pressure (barg)	Orifice area, cm ²					
	D (0.782)	E (1.392)	F (2.174)	G (3.568)	H (5.574)	J (9.129)
0.2	1	3	4	6	10	17
0.5	2	4	6	10	16	26
1.0	3	6	9	14	23	37
2.0	4	8	12	20	32	52
3.0	5	10	15	25	39	64
4.0	6	11	18	29	45	74
5.0	7	13	20	32	50	83
6.0	8	14	22	35	55	90
7.0	8	15	23	38	60	98
8.0	9	16	25	41	64	104
9.0	9	17	26	43	68	111
10.0	10	18	28	46	71	117
12.0	11	19	30	50	78	128
14.0	12	21	33	54	84	138
16.0	13	23	35	58	90	148
18.0	13	24	37	61	96	157
20.0	14	25	39	65	101	165
22.0	15	26	41	68	106	173
24.0	16	28	43	71	110	181
26.0	16	29	45	74	115	188
28.0	17	30	47	76	119	195
30.0	17	31	48	79	123	202
32.0	18	32	50	82	128	209
34.0	18	33	51	84	131	215
36.0	19	34	53	87	-	-
38.0	20	35	54	89	-	-
40.0	20	36	56	91	-	-
42.0	21	36	-	-	-	-
44.0	21	37	-	-	-	-
46.0	21	38	-	-	-	-
48.0	22	39	-	-	-	-
50.0	22	40	-	-	-	-
52.0	23	41	-	-	-	-
54.0	23	41	-	-	-	-
56.0	24	42	-	-	-	-
58.0	24	43	-	-	-	-
60.0	25	44	-	-	-	-
62.0	25	44	-	-	-	-
64.0	25	-	-	-	-	-
66.0	26	-	-	-	-	-
68.0	26	-	-	-	-	-
70.0	26	-	-	-	-	-
72.0	27	-	-	-	-	-
76.0	28	-	-	-	-	-
80.0	28	-	-	-	-	-
84.0	29	-	-	-	-	-
88.0	30	-	-	-	-	-
92.0	30	-	-	-	-	-
96.0	31	-	-	-	-	-

NOTE

1. See specifications table (pages 3 and 9) for pressure and temperature limitations.

KUNKLE SERIES 900 SAFETY RELIEF VALVES

SAFETY AND RELIEF PRODUCTS

Capacities - Models 910, 911, 912, 913, 916, 917, 918 and 919 (continued)

NON-CODE VACUUM AIR - 10% Accumulation, (U.S., SCFM) Flow coefficient = 0.878

Set inches Mercury	Orifice area, in ²					
	D (0.1213)	E (0.2157)	F (0.3369)	G (0.553)	H (0.864)	J (1.415)
6	24	43	68	111	173	284
7	26	45	71	117	182	298
8	27	47	74	121	189	310
9	27	49	76	125	195	320
10	28	50	78	128	199	327
11	28	51	79	129	202	331
12	29	51	80	131	204	334
13	29	51	80	131	204	335
14	29	51	80	131	204	335
15	29	51	80	131	204	335
16	29	51	80	131	204	335
17	29	51	80	131	204	335
18	29	51	80	131	204	335
19	29	51	80	131	204	335
20	29	51	80	131	204	335
21	29	51	80	131	204	335
22	29	51	80	131	204	335
23	29	51	80	131	204	335
24	29	51	80	131	204	335
25	29	51	80	131	204	335
26	29	51	80	131	204	335
27	29	51	80	131	204	335
28	29	51	80	131	204	335
29	29	51	80	131	204	335

KUNKLE SERIES 900 SAFETY RELIEF VALVES

SAFETY AND RELIEF PRODUCTS

Capacities - Models 910, 911, 912, 913, 916, 917, 918 and 919 (continued)

NON-CODE VACUUM AIR - 10% Accumulation, (Metric, Nm³/h) Flow coefficient = 0.878

Set pressure (mbarg)	Orifice area, cm ²					
	D (0.782)	E (1.392)	F (2.174)	G (3.568)	H (5.574)	J (9.129)
200	40	71	111	182	285	466
225	42	74	115	189	296	485
250	43	76	119	196	306	501
275	44	78	123	201	314	515
300	45	80	125	206	321	526
325	46	82	127	209	327	535
350	46	83	129	212	331	542
375	47	83	130	214	334	548
400	47	84	131	215	336	551
425	47	84	132	216	337	553
450	47	84	132	216	337	552
475	47	84	132	216	338	553
500	47	84	132	216	338	553
525	47	84	132	216	338	553
550	47	84	132	216	338	553
575	47	84	132	216	338	553
600	47	84	132	216	338	553
625	47	84	132	216	338	553
650	47	84	132	216	338	553
675	47	84	132	216	338	553
700	47	84	132	216	338	553
725	47	84	132	216	338	553
750	47	84	132	216	338	553
775	47	84	132	216	338	553
800	47	84	132	216	338	553
845	47	84	132	216	338	553
850	47	84	132	216	338	553
875	47	84	132	216	338	553
900	47	84	132	216	338	553
925	47	84	132	216	338	553
950	47	84	132	216	338	553
975	47	84	132	216	338	553
1000	47	84	132	216	338	553

NOTE

Viton® is a registered trademark of The Chemours Company.

Kalrez® is a registered trademark of E.I. du Pont de Nemours and Company.

AFLAS® is a registered trademark of the Asahi Glass Co., Ltd.

VCTDS-00392-EN © 2016, 2023 Emerson Electric Co. All rights reserved 01/23. Kunkle Valve is a mark owned by one of the companies in the Emerson Automation Solutions business unit of Emerson Electric Co. The Emerson logo is a trademark and service mark of Emerson Electric Co. All other marks are the property of their prospective owners.

The contents of this publication are presented for informational purposes only, and while every effort has been made to ensure their accuracy, they are not to be construed as warranties or guarantees, express or implied, regarding the products or services described herein or their use or applicability. All sales are governed by our terms and conditions, which are available upon request. We reserve the right to modify or improve the designs or specifications of such products at any time without notice.

Emerson Electric Co. does not assume responsibility for the selection, use or maintenance of any product. Responsibility for proper selection, use and maintenance of any Emerson Electric Co. product remains solely with the purchaser.

Emerson.com