



SERIES CS CLAPET VALVE

In compliance with PED 97/23/EC



TECHNICAL DETAILS

Wafer design	Metal/metal seat or soft seal (NBR, EPDM, PTFE, FKM)
Self-centering	Series DN 32 - DN 350
Light weight and small face to face	Suitable for flanges EN1092-1:2001 PN6, 10, 16, 25 and ANSI150 RF Further materials and special execution upon request: - series ANSI 300 + ANSI 1500 RF e RTJ - series PN 40 + PN 250
Low pressure drop	
Easy to install and maintenance	
Standard materials: zinc plated carbon steel, stainless steel 316, alu-bronze	

WORKING PRESSURE

PN6	6 Kg/cm ²	85 Psi
PN10	10 Kg/cm ²	142 Psi
PN16	16 Kg/cm ²	227 Psi
PN25	25 Kg/cm ²	355 Psi
ANSI150	20 Kg/cm ²	284 Psi

MINIMUM OPENING PRESSURE (mbar)

Flow Direction	DN 32 : DN 150	DN 200 : DN 300
Horizontal open 10° →	13	15
Horizontal open 30° →	19	25
Horizontal open 60° →	23	32
Vertical unphill ↑	26	35
Vertical downphill ↓	10	10

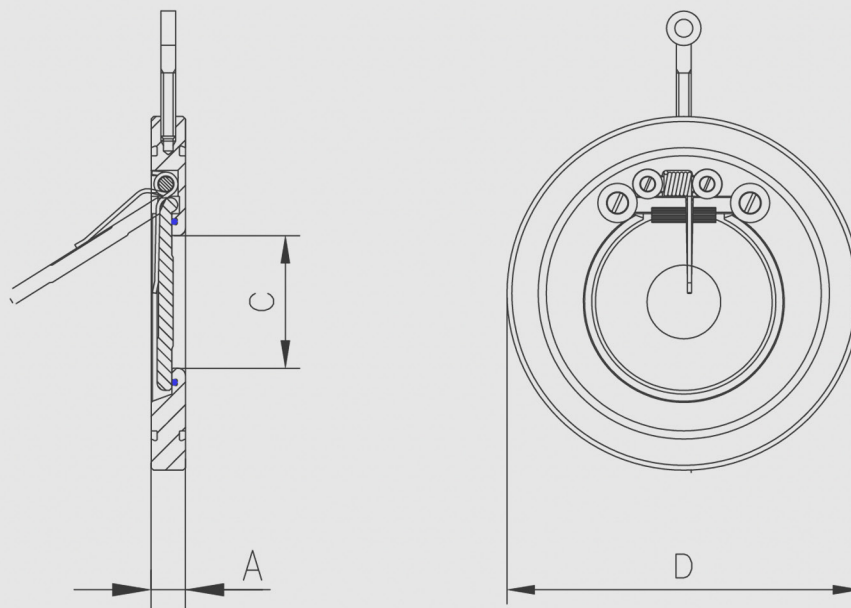
DIMENSIONS

DN		A	C	D PN6	D PN10	D PN16	D PN25	D ANSI150	WT PN10
mm	inch								Kg
32	1" ¹ / ₄	14	17	78	84	84	84	76	0,6
40	1" ¹ / ₂	14	22	88	95	95	95	86	0,7
50	2"	14	32	98	109	109	109	105	0,9
65	2" ¹ / ₂	14	40	118	129	129	129	124	1,2
80	3"	14	54	134	144	144	144	137	1,5
100	4"	18	70	154	164	164	170	175	2,4
125	5"	18	92	184	195	195	198	195	3,4
150	6"	20	112	209	220	220	228	220	4,6
200	8"	22	154	264	275	275	285	279	7,5
250	10"	26	200	319	330	330	340	340	13,1
300	12"	32	240	375	380	387	403	410	20,4
350	14"	38	270	425	440	448	460	448	32

* DN40 ANSI150 standard with raised face, no external orings