

No.	Part Name	Material	Qty.
1	Body	CF8M	1
2	Cap	CF8M	1
3	Ball	SS 316	1
4	Seat	RPTFE	2
5	Joint Gasket	PTFE	1
6	Stem	SS 316	1
7	Stem Seal	RPTFE	1
8	Stem Packing	PTFE	2
9	Stem Packing	25% Glass Fiber filled + PTFE	1
10	Gland	SS 316	1
11	Belleville Washer	SUS 301	2
12	Locking Plate	SS 316	1
13	Lock Saddle	SS 316	1
14	Stem Nut	SS 316	2
15	Locking Device	SS 316	1
16	Handle	SS 316	1
17	Handle Sleeve	Vinyl	1
18	Stop Pin	SS 316	1
19	Bolt	SS 316	4
20	Bolt (Stud & Nut)	SS 316	4
21	Anti-staic Device	SS 316	2
22	O-RING	VITON	1

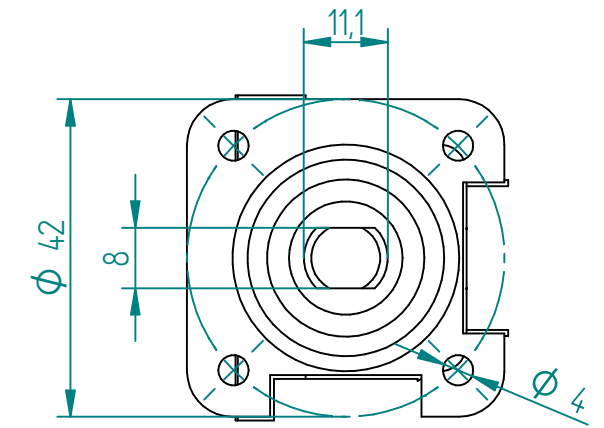

1:1 Dual Patern
ISO 5211 Mounting Pad



DRAWN	NAME	DATE	SIZE	DWG NO
	MOTO	14.03.2018	A3	MAR00500
CHECKED	TOCO	14.03.2018	FILE NAME: MAR00500.dft	
ENG APPR	TOCO	14.03.2018	SCALE: 1:1,5	REV:
MGR APPR	TOCO	14.03.2018	WEIGHT: 1,69 kg	SHEET: 1 OF 1

UNLESS OTHERWISE SPECIFIED DIMENSIONS ARE IN MILLIMETERS AND TOLERANCES ARE +/-0,5

REV	DESCRIPTION	DATE	APPROVED
REVISION HISTORY			

TITLE BALL VALVE MARS 90-10 FULL BORE 1/2" ANSI 150