

No.	Part Name	Material	Qty.
1	Body	CF8M	1
2	End Cap	CF8M	1
3	Ball	SS 316	1
4	Seat	SS 316 / PTFE	2
5	Joint Gasket	PTFE	1
6	Joint Gasket	PTFE	1
7	Stem Seal	RPTFE	1
8	Stem	SS 316	1
9	Stem Packing	PTFE	3
10	Stem Packing	25% Glass Fiber filled + PTFE	1
11	Gland	SS 316	1
12	Belleville Washer	SUS 301	2
13	Lock Saddle	SS 316	1
14	Stem Nut	SS 316	2
15	Stem Washer	SS 316	1
16	Handle	SS 316	1
17	Locking Device	SS 316	1
18	Handle Sleeve	Vinyl	1
19	Stop Pin	SS 316	1
20	Pin Nut	SS 316	1
21	Anti-Static Device	SS 316	2
22	O-RING	VITON	1
23	Washer	SS 304	

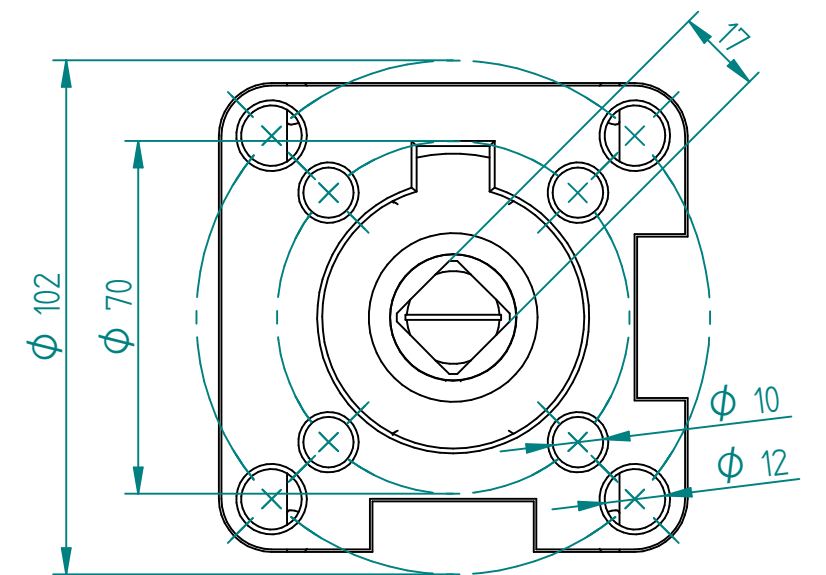

Dual Patern 1:15  
ISO 5211 Mounting Pad



TITLE	NAME		DATE	SIZE	DWG NO	UNLESS OTHERWISE SPECIFIED DIMENSIONS ARE IN MILLIMETERS AND TOLERANCES ARE +/-0,5
	DRAWN	MOTO	19.03.2018	A3	MAR00356B	
	CHECKED	TOCO	19.03.2018	FILE NAME: MAR00356B.dft		
	ENG APPR	TOCO	dd.mm.yyyy	SCALE: 1:2,5	REV: .....	
MGR APPR	TOCO	dd.mm.yyyy	WEIGHT: 11,88 kg	SHEET: 1 OF 1		

BALL VALVE MARS 99-1F  
V.PORT 60 DEGREE DN65 PN16

REV	DESCRIPTION	DATE	APPROVED
REVISION HISTORY			