

No.	Part Name	Material	Qty.
1	Body	CF8M	1
2	Cap	CF8M	1
3	Ball	SS 316	1
4	Seat	RPTFE	2
5	Joint Gasket	PTFE	1
6	Stem	SS 316	1
7	Stem Seal	RPTFE	1
8	Stem Packing	PTFE	3
9	Stem Packing	25% Glass Fiber filled + PTFE	1
10	Gland	SS 316	1
11	Belleville Washer	SUS 301	2
12	Lock Saddle	SS 316	1
13	Stem Nut	SS 316	2
14	Stem Washer	SS 316	1
15	Handle	SS 316	1
16	Handle Sleeve	Vinyl	1
17	Stud & Nuts	SS 316	10
18	Bolt	SS 316	10
19	Stop Pin	SS 316	1
20	Pin Nut & Washer	SS 316	1
21	Locking Device	SS 316	1
22	Anti-staic Device	SS 316	2
23	O-RING	VITON	1

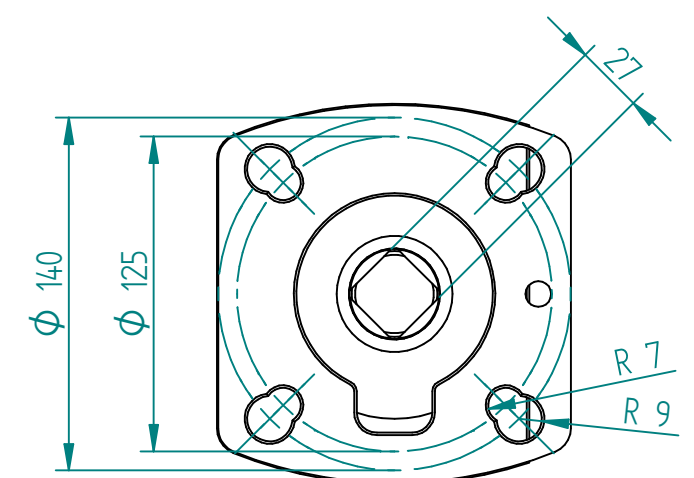

1:3 Dual Patern
ISO 5211 Mounting Pad



	NAME	DATE	SIZE	DWG NO
DRAWN	MOTO	18.06.2014	A3	MAR00311
CHECKED	TOCO	23.05.2014	FILE NAME: MAR00311.dft	
ENG APPR	TOCO	dd.mm.yyyy	SCALE: 1:5	REV:
MGR APPR	TOCO	dd.mm.yyyy	WEIGHT: 69,38 kg	SHEET: 1 OF 1

UNLESS OTHERWISE SPECIFIED DIMENSIONS ARE IN MILLIMETERS AND TOLERANCES ARE +/-0,5

TITLE BALL VALVE MARS 90D-40 F4 FULL BORE 6" PN 16

REV	DESCRIPTION	DATE	APPROVED
REVISION HISTORY			