

No.	Part Name	Material	Qty.
1	Body	CF8M	1
2	End Cap	CF8M	2
3	Ball	SS 316	1
4	Stem	SS 316	1
5	Stem Nut	SS 304 / SS 316	2
6	Stem Washer	SS 304 / SS 316	2
7	Handle	SS 304 / SS 316	1
8	Seat	PTFE	2
9	Gland Nut	SS 304 / SS 316	1
10	Stem Packing	PTFE	1
11	Stem Seal	PTFE	1
12	Bolt Washer	SS 304 / SS 316	4
13	Joint Gasket	PTFE	2
14	Bolt	SS 304 / SS 316	4
15	Locking Device	SS 304 / SS 316	1
16	Handle Sleeve	Vinyl	1
17	Bolt Nut	SS 304 / SS 316	4
18	Handle Washer	SS 304 / SS 316	1

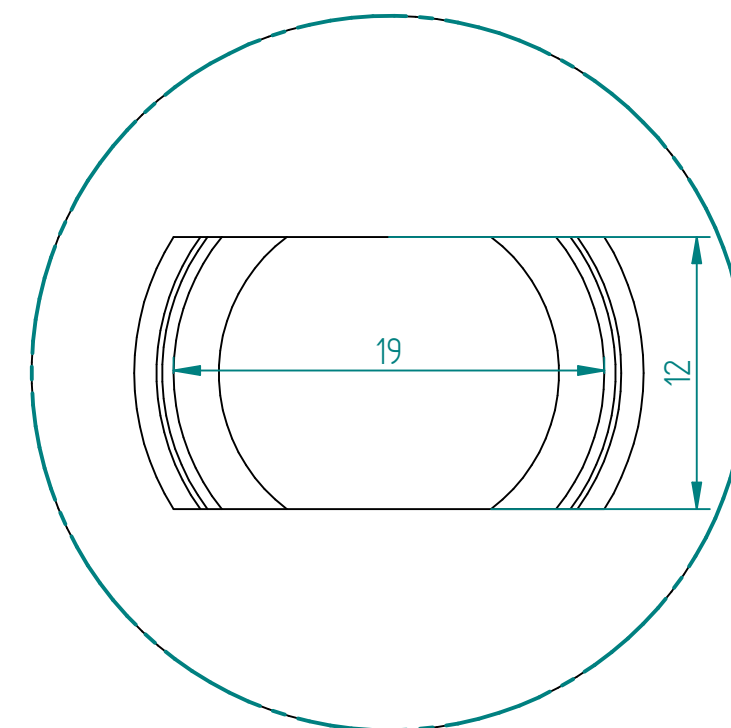

DETAIL A
3:1



DRAWN	NAME	DATE	SIZE	DWG NO
	MOTO	24.05.2019	A3	MAR00069
CHECKED	ERKJ	dd.mm.yyyy	FILE NAME: MAR00069.dft	
ENG APPR	ERKJ	dd.mm.yyyy	SCALE: 1:2,5	REV:
MGR APPR	ERKJ	dd.mm.yyyy	WEIGHT: 7,10 kg	SHEET: 1 OF 1

UNLESS OTHERWISE SPECIFIED DIMENSIONS ARE IN MILLIMETERS AND TOLERANCES ARE +/-0,5

REV	DESCRIPTION	DATE	APPROVED
REVISION HISTORY			

TITLE BALL VALVE MARS 50-30
3-PIECE 2 1/2" PN70 BW