

| No. | Part Name | Material | Qty. |
|-----|----------------|-----------------|------|
| 1 | Body | CF8M | 1 |
| 2 | End Cap | CF8M | 2 |
| 3 | Ball | SS 316 | 1 |
| 4 | Stem | SS 316 | 1 |
| 5 | Stem Nut | SS 304 / SS 316 | 2 |
| 6 | Stem Washer | SS 304 / SS 316 | 2 |
| 7 | Handle | SS 304 / SS 316 | 1 |
| 8 | Seat | PTFE | 2 |
| 9 | Gland Nut | SS 304 / SS 316 | 1 |
| 10 | Stem Packing | PTFE | 1 |
| 11 | Stem Seal | PTFE | 1 |
| 12 | Bolt Washer | SS 304 / SS 316 | 4 |
| 13 | Joint Gasket | PTFE | 2 |
| 14 | Bolt | SS 304 / SS 316 | 4 |
| 15 | Locking Device | SS 304 / SS 316 | 1 |
| 16 | Handle Sleeve | Vinyl | 1 |
| 17 | Bolt Nut | SS 304 / SS 316 | 4 |
| 18 | Handle Washer | SS 304 / SS 316 | 1 |

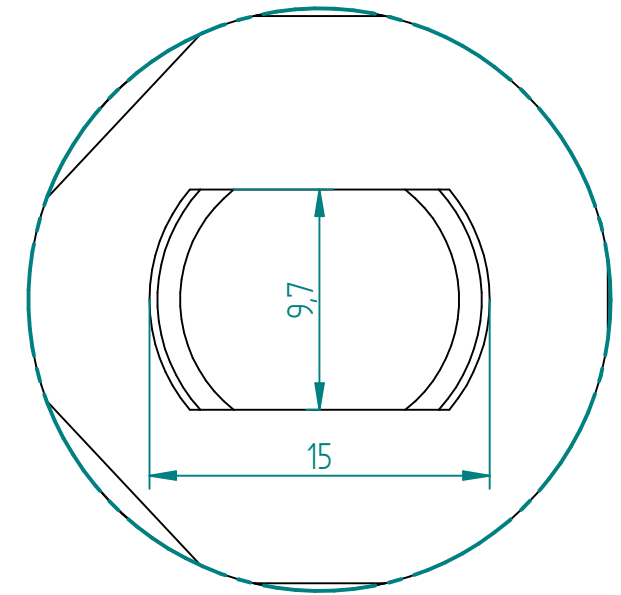

DETAIL A
3:1



| | | | | | | |
|----------|---|------------|-----------------|---------------|-------------------------|--|
| TITLE | BALL VALVE MARS 50-30 3-PIECE 2" PN70 BW | NAME | DATE | SIZE | DWG NO | UNLESS OTHERWISE SPECIFIED DIMENSIONS ARE IN MILLIMETERS AND TOLERANCES ARE +/-0,5 |
| | | DRAWN | MOTO | 24.05.2019 | A3 MAR00068 | |
| | | CHECKED | ERKJ | dd.mm.yyyy | FILE NAME: MAR00068.dft | |
| | | ENG APPR | ERKJ | dd.mm.yyyy | SCALE: 1:2 | |
| MGR APPR | ERKJ | dd.mm.yyyy | WEIGHT: 3,66 kg | SHEET: 1 OF 1 | | |

| REV | DESCRIPTION | DATE | APPROVED |
|------------------|-------------|------|----------|
| REVISION HISTORY | | | |