

No.	Part Name	Material	Qty.
1	Body	CF8M	1
2	End Cap	CF8M	2
3	Ball	SS 316	1
4	Stem	SS 316	1
5	Stem Nut	SS 304 / SS 316	2
6	Stem Washer	SS 304 / SS 316	2
7	Handle	SS 304 / SS 316	1
8	Seat	PTFE	2
9	Gland Nut	SS 304 / SS 316	1
10	Stem Packing	PTFE	1
11	Stem Seal	PTFE	1
12	Bolt Washer	SS 304 / SS 316	4
13	Joint Gasket	PTFE	2
14	Bolt	SS 304 / SS 316	4
15	Locking Device	SS 304 / SS 316	1
16	Handle Sleeve	Vinyl	1
17	Bolt Nut	SS 304 / SS 316	4
18	Handle Washer	SS 304 / SS 316	1

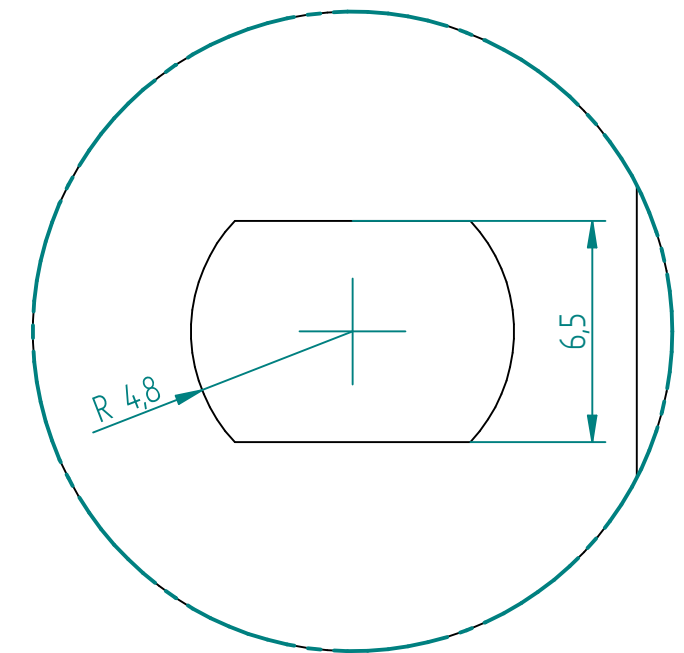

DETAIL A



TITLE	BALL VALVE MARS 50-30 3-PIECE 3/4" PN70 BW	NAME	DATE	SIZE	DWG NO	UNLESS OTHERWISE SPECIFIED DIMENSIONS ARE IN MILLIMETERS AND TOLERANCES ARE +/-0,5
		DRAWN	MOTO	24.05.2019	A3 MAR00064	
		CHECKED	ERKJ	dd.mm.yyyy	FILE NAME: MAR00064.dft	
		ENG APPR	ERKJ	dd.mm.yyyy	SCALE: 1:1,11	
MGR APPR	ERKJ	dd.mm.yyyy	WEIGHT: 0,75 kg	SHEET: 1 OF 1		

REV	DESCRIPTION	DATE	APPROVED
REVISION HISTORY			