

No.	Part Name	Material	Qty.
1	Body	CF8M	1
2	End Cap	CF8M	2
3	Ball	SS 316	1
4	Stem	SS 316	1
5	Stem Nut	SS 304 / SS 316	2
6	Stem Washer	SS 304 / SS 316	2
7	Handle	SS 304 / SS 316	1
8	Seat	PTFE	2
9	Gland Nut	SS 304 / SS 316	1
10	Stem Packing	PTFE	1
11	Stem Seal	PTFE	1
12	Bolt Washer	SS 304 / SS 316	4
13	Joint Gasket	PTFE	2
14	Bolt	SS 304 / SS 316	4
15	Locking Device	SS 304 / SS 316	1
16	Handle Sleeve	Vinyl	1
17	Bolt Nut	SS 304 / SS 316	4
18	Handle Washer	SS 304 / SS 316	1

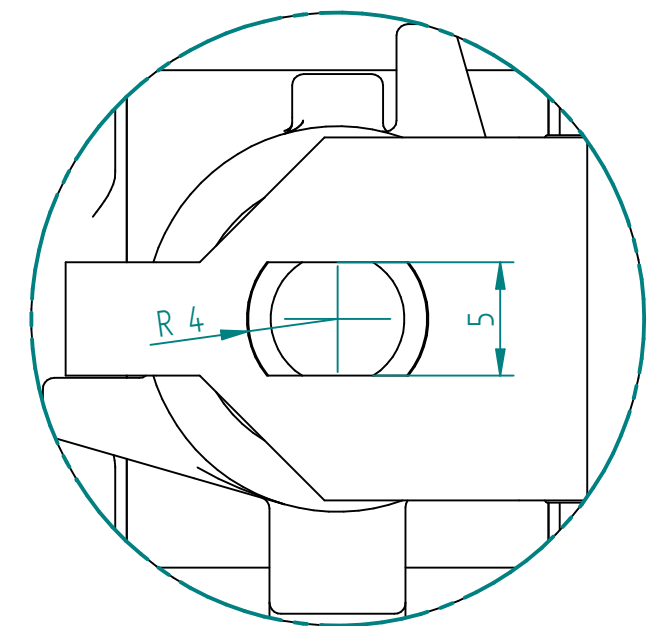

DETAIL A  
3:1

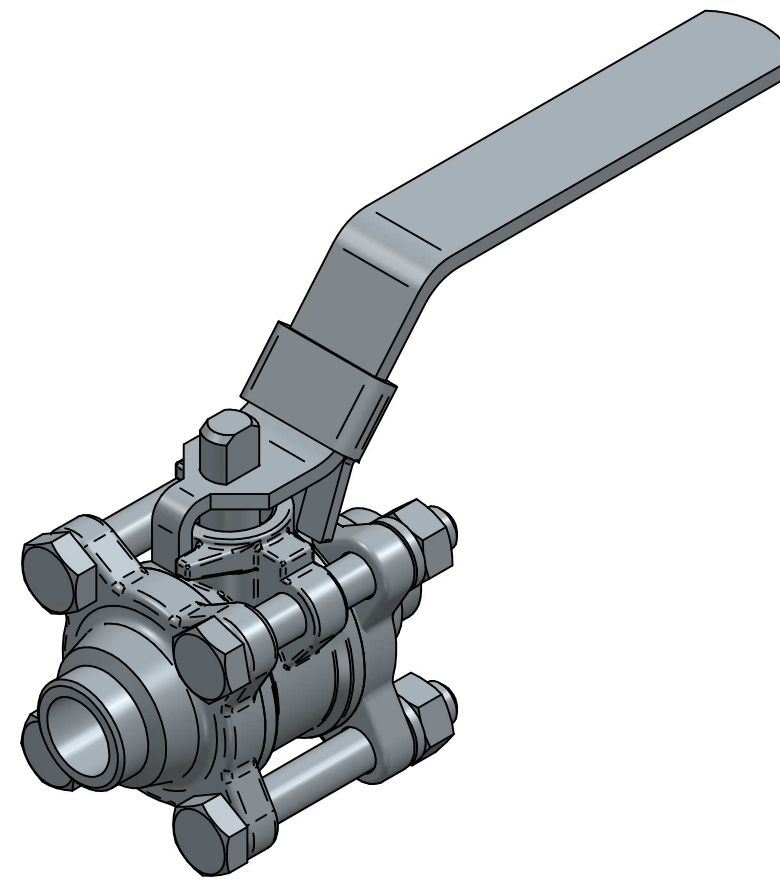
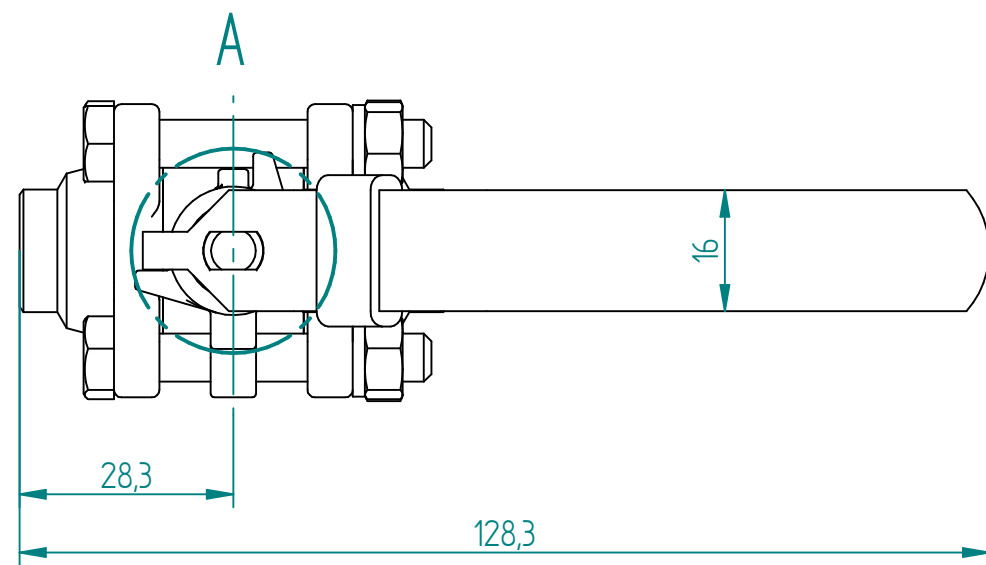

		NAME	DATE	SIZE	DWG NO
DRAWN	MOTO	23.05.2019	<b>A3</b>	MAR00061	
CHECKED	ERKJ	dd.mm.yyyy	FILE NAME: MAR00061.dft		
ENG APPR	ERKJ	dd.mm.yyyy	SCALE: 1:1	REV: .....	
MGR APPR	ERKJ	dd.mm.yyyy	WEIGHT: 0,35 kg	SHEET: 1 OF 1	

UNLESS OTHERWISE SPECIFIED DIMENSIONS ARE IN MILLIMETERS AND TOLERANCES ARE +/-0,5

REV	DESCRIPTION	DATE	APPROVED
REVISION HISTORY			

TITLE BALL VALVE MARS 50-30  
3-PIECE 1/4" PN70 BW