

Y-Strainer
 #12/ #40/ #60 Mesh
 800 PSI
 ¼" (DN8) to 3" (DN80)

MATERIALS LIST

NO.	PART NAME	MATERIAL	Q'TY
1	BODY	ASTM A351 Gr. CF8M	1
2	SCREEN	SUS 316	1
3	GASKET PACTING	TEFLON(PTFE)	1
4	BONNET	ASTM A351 Gr. CF8M	1
5	PLUG GASKET	TEFLON(PTFE)	1
6	Blow Off Plug	ASTM A351 Gr. CF8M	1

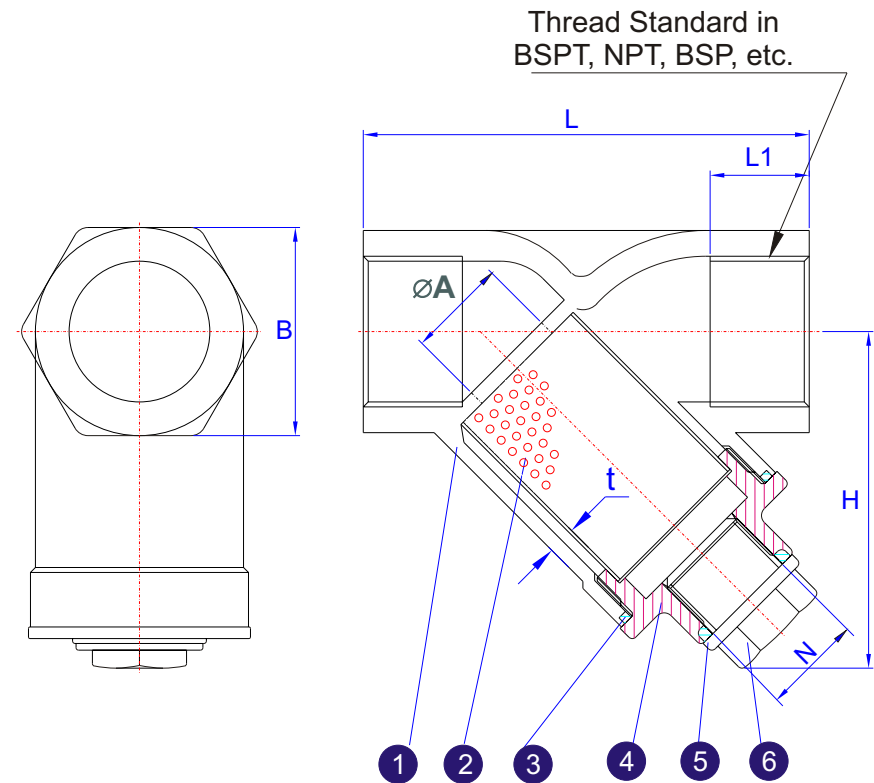

Pressure Vs. Temperature Chart
 for Valve Y[#] (DN8) to 3"(DN80)

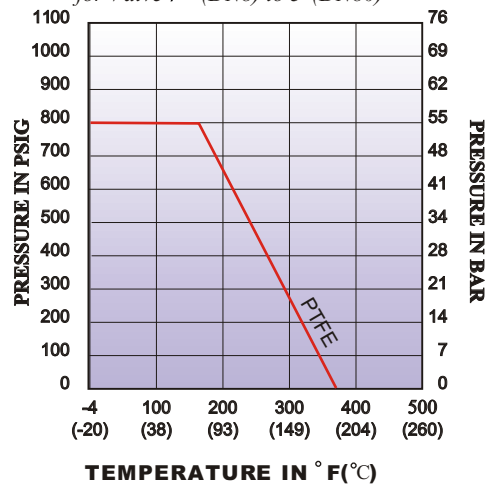

DIMENSIONS (mm)

SIZE	B	ØA	H	L	L1	t	N	W(kg)
¼"	23	11.0	46	65	13.5	3.0	M13x19	0.24
⅜"	23	13.0	46	65	14.0	3.0	M13x19	0.23
½"	26	15.0	46	65	15.0	3.0	M13x19	0.23
¾"	32	20.0	55	80	17.0	3.0	M13x19	0.36
1"	41	25.0	70	90	19.0	3.5	M20x16	0.70
1¼"	50.5	32.0	73	105	20.0	3.6	M20x16	0.90
1½"	57	38.0	81	120	22.0	4.0	M20x16	1.20
2"	69	50.0	94	140	23.5	4.3	M20x16	1.90
2½"	87	65.0	120	170	29.0	5.6	M20x16	4.3
3"	102	80.0	140	200	31.0	6.5	M20x16	6.3