

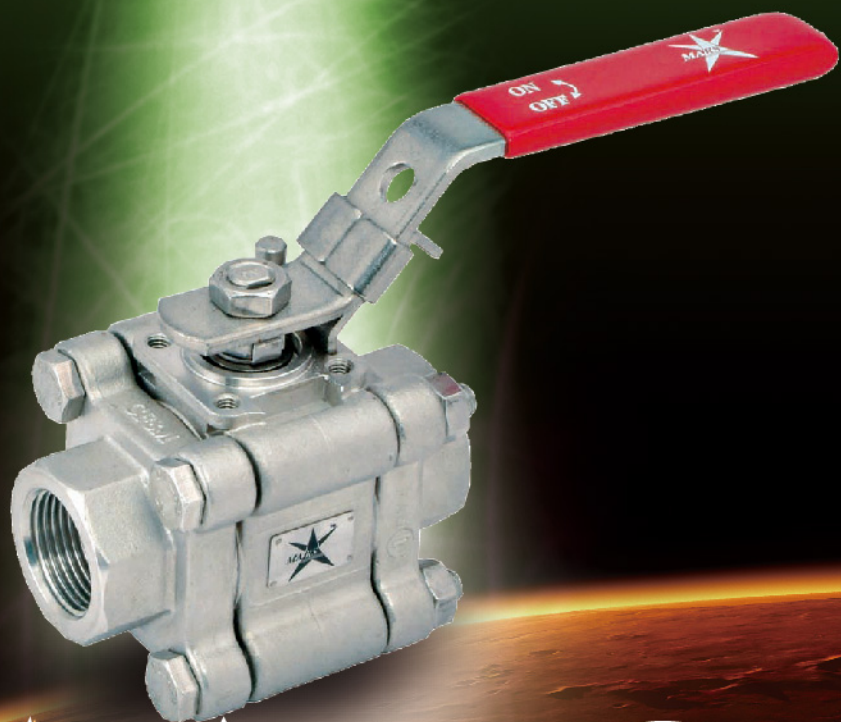

Take
a Good Look
It May Be Your Future



MARS

SERIES 83

HEAVY DUTY
3 PIECE BALL VALVES
1/4" TO 2 1/2" FULL PORT AND REDUCED PORT

www.marsvalve.com.tw



SERIES 83

Heavy Duty Three-Piece Ball Valves

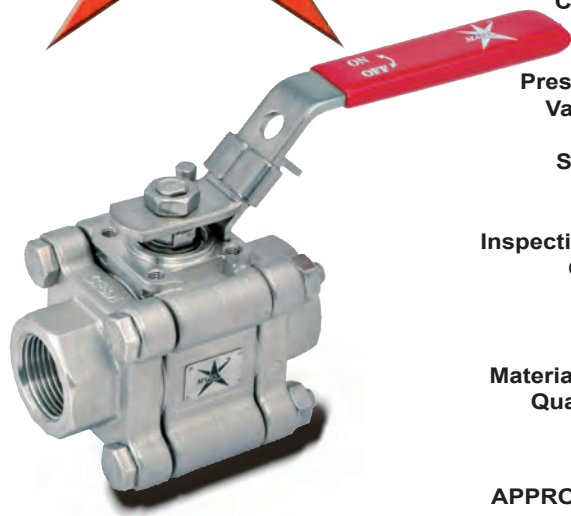

- Construction** 3-Piece In-Line Swing Out Design, Full Port or Reduced Port
- Size Range** Full Port: 1/4" to 2" (DN 8 to DN 50)
Reduced Port: 1/2" to 2 1/2" (DN 15 to DN 65)
- Pressure Rating** 1/4"-1": 2000 PSI 1 1/4"-2": 1500 PSI
- Valve Material** Standard: ASTM A351 Gr. CF8M / EN 10213 1.4408
Options: WCB/1.0619, CF3M/1.4409, Titanium, Duplex S/S, Hastelloyetc.
- Seat Material** Standard: R-TFE
Options: TFM 1600, PEEK, Carbon filled PTFE, Delrin, UHMWPE, 50/50 S/S filled PTFE...and others
- Inspection and Test** API 598
- Compliance Standards** ASME B16.34, NPT ASME B1.20.1, BSPP ISO 228-1, BSPT ISO 7-1, DIN2999, SW ASME B16.11, BW ASME B16.25, EN 1092-1, ASME B16.5 Class 150, ISO 5211, ISO 5209
* For valves full compliance with ASME B16.34, please consult factory
- Material Certificate** EN 10204 - 3.1
- Quality System** ISO 9001
- Options** NACE MR - 0175
Standard valve is non-fire safe design, fire safe valve is optional

APPROVALS



SIL 3



Fire safe tested
API 607 Rev 6



0035
PED 2014/68/EU
Category II
Module H



TA-Luft



ATEX 2014/34/EU

Mars Unique SealMax[®] Triple-Sealing Stem Packing System - Live Loaded - Maintenance Free - Extra Long Cycle Life - TA-Luft Approved

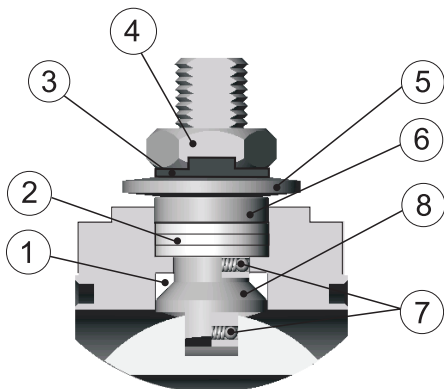

1. Pyramidal Stem with Stem Seal

First stage of defense against leakage. The 45° slope of the stem accompany the stem seal effectively blocks all leak path during rotation.

2. V-Ring Stem Packing

Second stage of defense against leakage. Multiple layers of V-Ring Chevron Packing expands side way as it is being compressed, blocking all air pockets to prevent leak path.

3 Lock Saddle

Stabilizes the entire stem nut to keep it from loosening during operation

4. Stem Nut

Compress the entire stem system to enable blocking of leakage

5. Belleville Washers

Automatically compress the seals to adjust for wear, pressure, and temperature fluctuations.

6. Gland

Made of stainless steel, equally distributes the compressive force on the packing and seal.

7. Anti-Static Device

Spring loaded stem-to-ball and stem-to-body anti-static device as standard

8. Super Smooth Stem Finish

Reduces seal friction and operating torque, prolongs service life.

Available End Connections

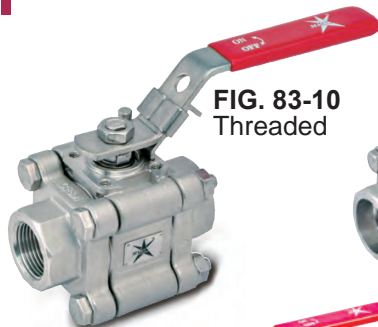

FIG. 83-10
Threaded



FIG. 83-20
Socket Weld



FIG. 83-30
Butt Weld

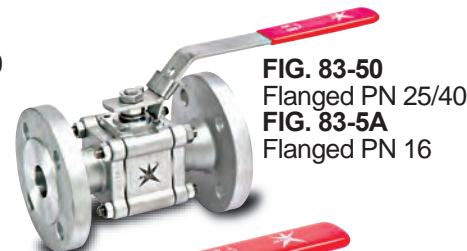

FIG. 83-50
Flanged PN 25/40
FIG. 83-5A
Flanged PN 16

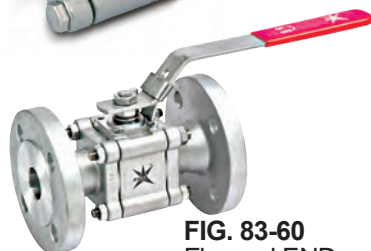

FIG. 83-60
Flanged END
ANSI 150LBS



FIG. 83-70
Tube(ISO), Butt Weld



SERIES 83
instrumentation Ball Valve



MARS OPTIONAL VALVE ACCESSORIES INCREASE PRODUCTIVITY AND GIVE YOU MORE CONTROL OVER YOUR INDUSTRIAL PROCESS



SERIES 83C
Cryogenic Ball Valves
 For low temperature to -196°C
 1/2" to 2", Full or Reduced Port

V-Control Ball Valves

Mars V-Control Ball valves match the control performance of globe valve, excellent for modulating service, but Mars V-Control ball valves are more compact, lighter weight, and much less expensive than globe valves.



30°V, 60°V, 90°V
 30°V, 60°V, 90°V are standard, others on request



Heating Jacket
 Jacket ball valve prevents solidification and blockage in use of hot water, steam, or other appropriate heating or cooling medium

3-Way Diverter Ball Valves

For Diversion, Mixing, and Blending applications
 Side Entry: T-Port, L-Port
 Bottom Entry: T-Port, L-Port, LL-Port

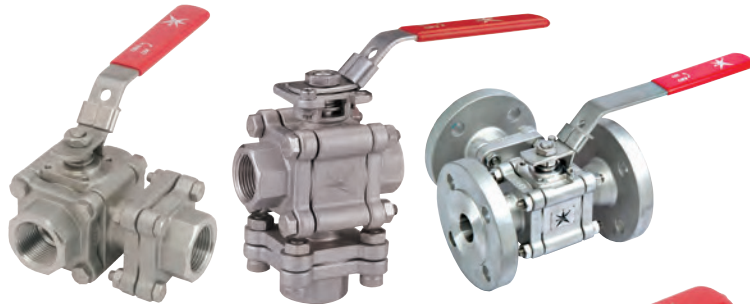

Tapped and Drilled
Eight (8) Body Bolts Design
 *Available on request

Titanium BALL VALVES

Light weight, Excellent for Corrosion Resistance
 Other special alloy available on request
 Monel, Hastelloy C, Alloy 20, Duplex



Mars "TSM" Unit adds Extra Safety and Long Service Life

- The TSM unit designed for possible fugitive emission to meet TA-Luft requirements for a safe and clean environment, and provides a secondary stem seal for the valve stem, prolongs service life.
- The TSM unit can also function as stem extension for insulation.
- ISO 5211 mounting pad and square shaft for direct actuator mounting with no brackets and adapters, ease of automation.
- Cast bosses for monitoring device

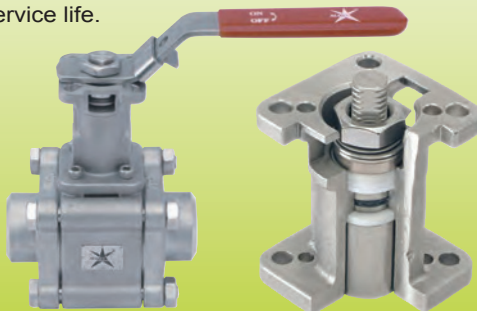

SERIES 83 HANDLE OPTIONS

SPRING RETURN SLIDING LOCK (SRSL) HANDLE MAKES OPERATION SAFE

No matter the orientation of the ball valves, the SRSL Handle always secures handle in position, make valve operation safe

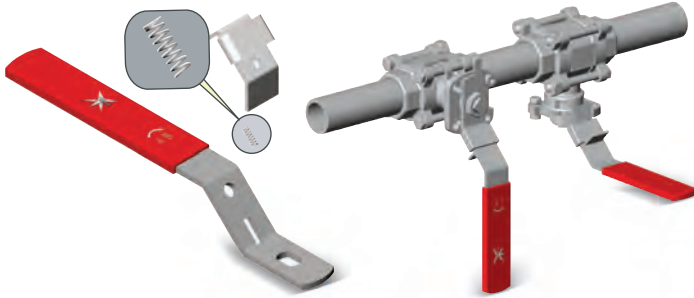

OVAL HANDLE



ECONOMICAL STEM EXTENSION

- 304SS Construction
- Cost effective
- Easy installation



EASY AUTOMATION

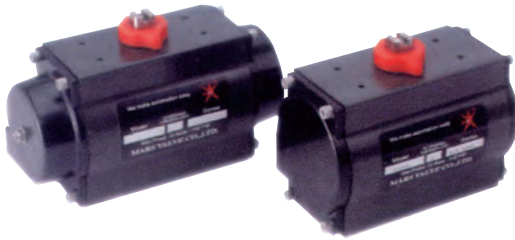

AirMars Pneumatic Actuator



PowerMars Electric Actuator



Brackets & Couplings

HOW TO ORDER 83-10 ST05B

83-10	S	T	05	B
VALVE	BODY MATERIAL	SEAT MATERIAL	SIZE	HANDLE STYLE
<input checked="" type="checkbox"/> 83-10 <input type="checkbox"/> 83-20 <input type="checkbox"/> 83-30 <input type="checkbox"/> 83-50 <input type="checkbox"/> 83-5A <input type="checkbox"/> 83-60 <input type="checkbox"/> 83-70	<input checked="" type="checkbox"/> S - CF8M <input type="checkbox"/> W - WCB <input type="checkbox"/> L - CF3M <input type="checkbox"/> D - Duplex <input type="checkbox"/> T - Titanium <input type="checkbox"/> A - Alloy 20	<input type="checkbox"/> P PTFE <input type="checkbox"/> R R-TFE <input checked="" type="checkbox"/> T TFM1600 <input type="checkbox"/> S 50/50 S.S.+PTFE <input type="checkbox"/> M MG1241 <input type="checkbox"/> C Carbon filled PTFE <input type="checkbox"/> U UHMWPE <input type="checkbox"/> K Peek <input type="checkbox"/> D Delrin <input type="checkbox"/> A Metal	<input type="checkbox"/> 01) 1/4" <input type="checkbox"/> 02) 3/8" <input type="checkbox"/> 03) 1/2" <input type="checkbox"/> 04) 3/4" <input checked="" type="checkbox"/> 05) 1" <input type="checkbox"/> 06) 1 1/4" <input type="checkbox"/> 07) 1 1/2" <input type="checkbox"/> 08) 2" <input type="checkbox"/> 09) 2 1/2"	<input type="checkbox"/> Std. handle <input type="checkbox"/> i - Investment Cast <input type="checkbox"/> O - Oval handle <input type="checkbox"/> L - SRSL handle <input type="checkbox"/> S - SRS handle <input checked="" type="checkbox"/> B - Bare shaft <input type="checkbox"/> G - Gear Box

Oslo ☎ 22 21 51 00 | Bergen ☎ 55 39 32 00 | Arendal ☎ 37 06 11 40

✉ post@jsc.no | 🏠 www.jsc.no

