



ISO 9001

# SERIES 10 & 20

ECONOMICAL  
ONE-PIECE / TWO-PIECE BALL VALVES  
STAINLESS STEEL AND CARBON STEEL  
THREADED ENDS 1000/1500/2000 PSI

## FEATURES

- For General Industrial and Chemical Applications, provides Safe, Economical Performance
- Economical Compact Design
- Blow-Out Proof Stem
- Low Operation Torque
- Investment Cast Body Construction

**FIG. 10-10 REDUCED PORT 1/4" TO 2" 1000 PSI**



### MATERIALS LIST

NO.	PART NAME	MATERIAL	QTY
1	Body	ASTM A351 Gr. CF8M	1
2	Cap	ASTM A351 Gr. CF8M	1
3	Ball	SUS 316	1
4	Stem	SUS 316	1
5	Stem Nut	SUS 304	1
6	Stem Washer	SUS 304	1
7	Handle	SUS 304	1
8	Seat	PTFE	2
9	Gland	SUS 304	1
10	Stem Packing	PTFE	1
11	Thrust Washer	PTFE	1
12	Handle Sleeve	Vinyl	1
13	Joint Gasket	PTFE	1
14	Locking Device	SUS 304	1

\* Available as an option

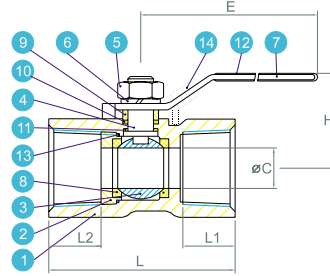
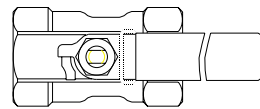

Pressure Vs. Temperature Chart

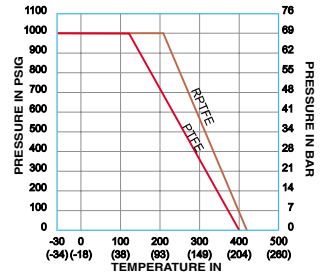

### DIMENSIONS(mm)

SIZE	ØC	E	H	L	L1	L2	W(Kg)
1/4"	5.0	64	35	39	11.0	7.0	0.07
3/8"	7.0	70	37	44	11.0	8.0	0.10
1/2"	9.2	90	44	57	16.0	14.0	0.16
3/4"	12.5	90	47	58	15.0	10.7	0.25
1"	15.0	103	50	71	17.4	17.0	0.43
1 1/4"	20.0	103	57	78	19.0	16.7	0.70
1 1/2"	25.0	127	69	83	19.1	16.6	0.83
2"	32.0	127	75	100	22.5	19.7	1.50

**FIG. 20-10 FULL PORT 1/4" TO 2" 1000 PSI**

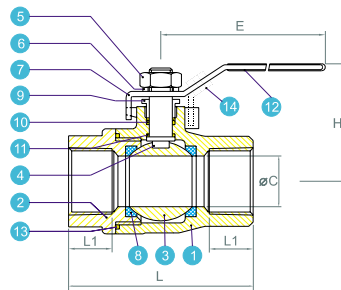
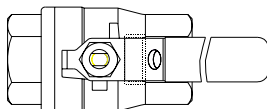

### DIMENSIONS(mm)

SIZE	ØC	E	H	L1	L	W(Kg)
1/4"	11.2	100	50	12	56	0.23
3/8"	12.6	100	50	13	56	0.23
1/2"	15.0	130	60	14	66	0.36
3/4"	20.0	130	64	16	72	0.47
1"	25.0	165	71	18	84	0.82
1 1/4"	32.0	165	78	20	94	1.17
1 1/2"	38.0	190	86	22	110	1.82
2"	50.0	190	95	25	126	2.83

**FIG. 20-20 FULL PORT 1/4" TO 3" 1000 PSI**

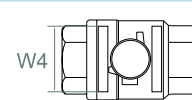
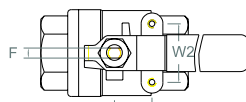

Top Mounting  
Location for 2 1/2" ~ 3"

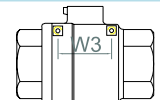

Side Mounting  
Location for 2 1/2" ~ 3"

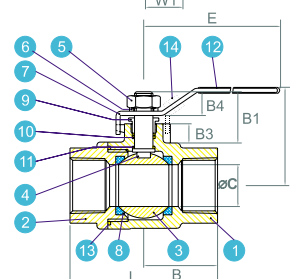

### DIMENSIONS(mm)

SIZE	B	B1	B3	B4	ØC	E	F	H	L	W1	W2	W3	W4	W(kg)
1/4"	27.5	23	8	10	11.6	100	5.0	50	55	12.7	28.5	N/A	N/A	0.23
3/8"	27.5	23	8	10	12.7	100	5.0	50	55	12.7	28.5	N/A	N/A	0.23
1/2"	32.5	26	10	12	15.0	130	6.5	60	65	12.7	28.5	N/A	N/A	0.38
3/4"	37.0	26	11	12	20.0	130	6.5	64	74	22.4	35.0	N/A	N/A	0.52
1"	44.0	30	12	15	25.0	165	8.0	71	88	22.4	35.0	N/A	N/A	0.92
1 1/4"	51.0	37	12	15	32.0	165	8.0	78	102	25.4	38.1	N/A	N/A	1.32
1 1/2"	55.0	35	12	16	38.0	190	9.7	86	110	25.4	38.1	N/A	N/A	1.90
2"	62.5	31	10	16	50.0	190	9.7	95	125	25.4	38.1	N/A	N/A	3.12
2 1/2"	81.5	51	18	25	65.0	250	12.0	130	182	N/A	N/A	59	61	6.50
3"	89.0	49	18	25	80.0	250	12.0	148	178	N/A	N/A	70	71	9.30

**FIG. 20-30 REDUCED PORT 1/4" TO 1" 2000 PSI 1 1/4" TO 2" 1500 PSI**

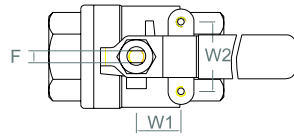

TOP VIEW

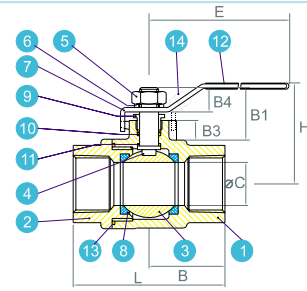

**DIMENSIONS(mm)**

SIZE	B	B1	B3	B4	ØC	E	F	H	L	W1	W2	W(kg)
1/4"	27.5	18.2	6	11.6	9.5	100	5.0	50	51	12.7	28.5	0.22
3/8"	27.5	18.2	6	11.6	11.6	100	5.0	50	51	12.7	28.5	0.22
1/2"	32.0	23.5	8	11.6	12.6	100	5.0	50	51	12.7	28.5	0.28
3/4"	37.5	25.0	11	11.6	15.0	130	6.5	53	68	22.4	35.0	0.45
1"	43.5	25.3	9	11.6	20.0	130	6.5	64	83	22.4	35.0	0.66
1 1/4"	51.0	33.5	13	15.2	25.0	165	8.0	66	90	22.4	35.0	1.08
1 1/2"	55.0	31.0	9	15.2	32.0	165	8.0	79	104	25.4	38.1	1.49
2"	63.0	31.6	9	16.6	38.0	190	9.7	83	117	25.4	38.1	2.32

**FIG. 20-40 FULL PORT 1/4" TO 1" 2000 PSI 1 1/4" TO 2" 1500 PSI**

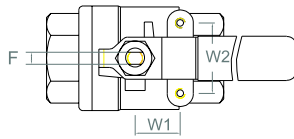

TOP VIEW

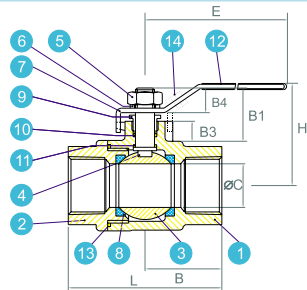

**DIMENSIONS(mm)**

SIZE	B	B1	B3	B4	ØC	E	F	H	L	W1	W2	W(kg)
1/4"	27.5	23	8	10	11.6	100	5.0	50	55	12.7	28.5	0.23
3/8"	27.5	23	8	10	12.7	100	5.0	50	55	12.7	28.5	0.23
1/2"	32.5	26	10	12	15.0	130	6.5	60	65	12.7	28.5	0.38
3/4"	37.0	26	11	12	20.0	130	6.5	64	74	22.4	35.0	0.52
1"	44.0	30	12	15	25.0	165	8.0	71	88	22.4	35.0	0.92
1 1/4"	51.0	37	12	15	32.0	165	8.0	78	102	25.4	38.1	1.32
1 1/2"	55.0	35	12	16	38.0	190	9.7	86	110	25.4	38.1	1.90
2"	62.5	31	10	16	50.0	190	9.7	95	125	25.4	38.1	3.12

**FIG. 20-50 FULL PORT 1/2" TO 3" 1000 PSI**

- Mounting Pad to DIN 3337/ISO 5211 with Center-Ring Top Fully machined.
- Live Loaded Stem Packing

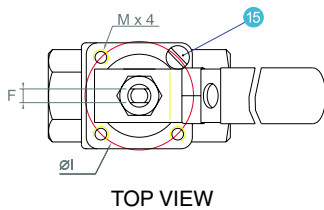

TOP VIEW

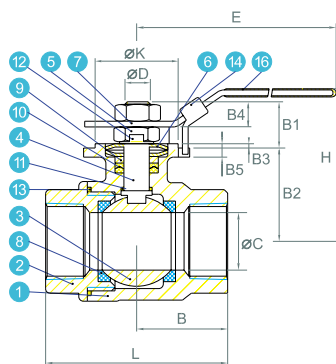

**DIMENSIONS(mm)**

SIZE	B	B1	B2	B3	B4	B5	ØC	ØD	E	F	H	ØI	ØK	L	M	ISO5211
1/2"	32.5	18.5	27.5	2	11.0	5	15.0	9.5	130	6.5	69	36	25	65.0	M5	F03
3/4"	37.2	20.5	32.6	2	12.0	5	20.0	9.5	130	6.5	74	36	25	74.5	M5	F03
1"	44.0	18.0	44.0	2	10.0	6	25.0	11.0	165	8.0	83	42	30	88.0	M6	F04
1 1/4"	51.3	18.0	49.6	2	11.0	6	32.0	11.0	165	8.0	92	42	30	102.0	M6	F04
1 1/2"	55.0	24.0	54.1	2	12.5	6	38.0	14.0	222	9.7	104	50	35	110.0	M8	F05
2"	64.9	24.0	62.5	2	12.5	6	50.0	14.0	222	9.7	104	50	35	127.5	M8	F05
2 1/2"	80.6	32.8	83.6	2	20.0	8	65.0	19.0	250	12.0	140	70	55	160.6	M8	F07
3"	91.0	32.8	92.3	2	20.0	8	80.0	19.0	250	12.0	149	102	70	178.0	M10	F10

**MATERIALS LIST**

NO.	PART NAME	MATERIAL	QTY
1	Body	ASTM A351 Gr. CF8M	1
2	End cap	ASTM A351 Gr. CF8M	1
3	Ball	SUS 316	1
4	Stem	SUS 316	1
5	Stem Nut	SUS 304	2
6	Belleville Washer	SUS 301	2
7	Handle	SUS 304	1
8	Seat	PTFE	2
9	Gland	SUS 304	1
10	V-Ring Packing	PTFE	1
11	Thrust Washer	PTFE	1
12	Lock Saddle	SUS 304	1
13	Joint Gasket	PTFE	1
14	Locking Device	SUS 304	1
15	Stop Pin	SUS 304	1
16	Handle Sleeve	Vinyl	1

1 Set of v-ring packing consists of 2pcs of v-ring

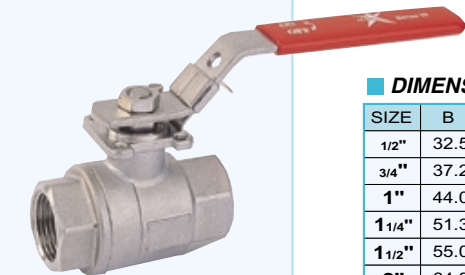

**MARS VALVE CO.,LTD.**  
 7F-6, NO.200, SEC. 4, WEN-SHIN ROAD  
 TAICHUNG, TAIWAN, R.O.C.  
 TEL:++886-4-297 3808  
 FAX:++886-4-297 3608  
 E-MAIL:mars@marsvalve.com.tw  
<http://www.marsvalve.com.tw/>

Distributor: