

Operating

Högfors strainer of carbon steel has been designed for collecting dirt and impurities in pipe systems. Strainer is used for example in district heating networks and in industry.

Nominal pressure

PN 40	DN 15 - 50
PN 25	DN 65 - 125
PN 16	DN 150

Operating temperature max +200°C/ min -20°C



Construction

Högfors welded strainer 38500 has a body of carbon steel. Filter is of stainless steel and the filter mesh is 0,6 x 0,6 mm. Perforation ratio is ca. 40%. Strainer can be drained by removing the stainless steel drain and flushing plug. Filter can be replaced by removing the cover.

Conform with the requirements of the Council Directive 97/23/EC on Pressure Equipment, marking:
 Class: Gas, group 2



Nominal dimensions: DN15 - 150

Product codes: 38500FR___N9E
 Unpainted weld ends

Dimensions

DN	Resistance coefficient	Kv100	D	s	L	H	h	R	Weight kg
15	2,4	5,8	21,3	2,0	230	83	22	G 1/2	1,0
20	2,3	10,5	26,9	2,3	230	90	25	G 1/2	1,3
25	2,0	17,6	33,7	2,6	230	105	30	G 1/2	1,7
32	2,0	28,9	42,4	2,6	260	114	35	G 1/2	2,8
40	1,9	46,0	48,3	2,9	260	122	40	G 1/2	3,0
50	2,2	69,0	60,3	2,9	300	146	47	G 1/2	5,4
65	1,8	126	76,1	2,9	300	197	68	G 1/2	8,0
80	1,9	184	88,9	3,2	300	215	78	G 1/2	11,0
100	2,7	242	114,3	3,6	325	268	109	G 1/2	17,7
125	1,2	636	139,7	4,0	325	347	135	G 3/4	25
150	1,6	807	168,3	4,5	350	345	143	G 3/4	40

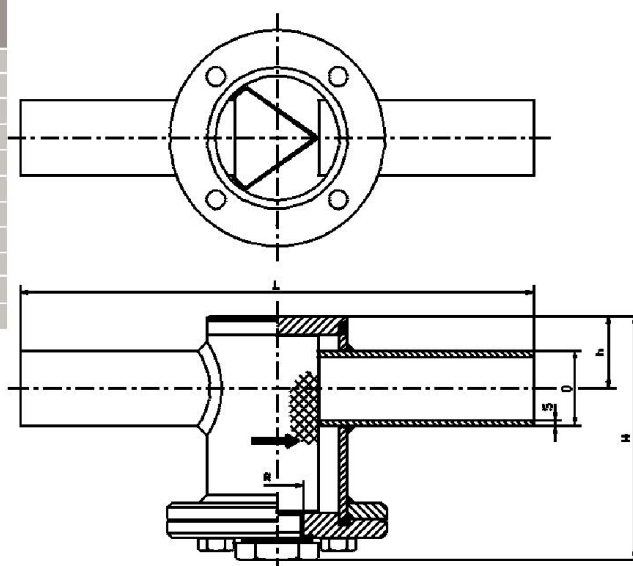

Materials

Body: EN 10216-2 P235GH, DIN 17175 ST35.8
 Filter: 1.4301
 Cover seal: FPM

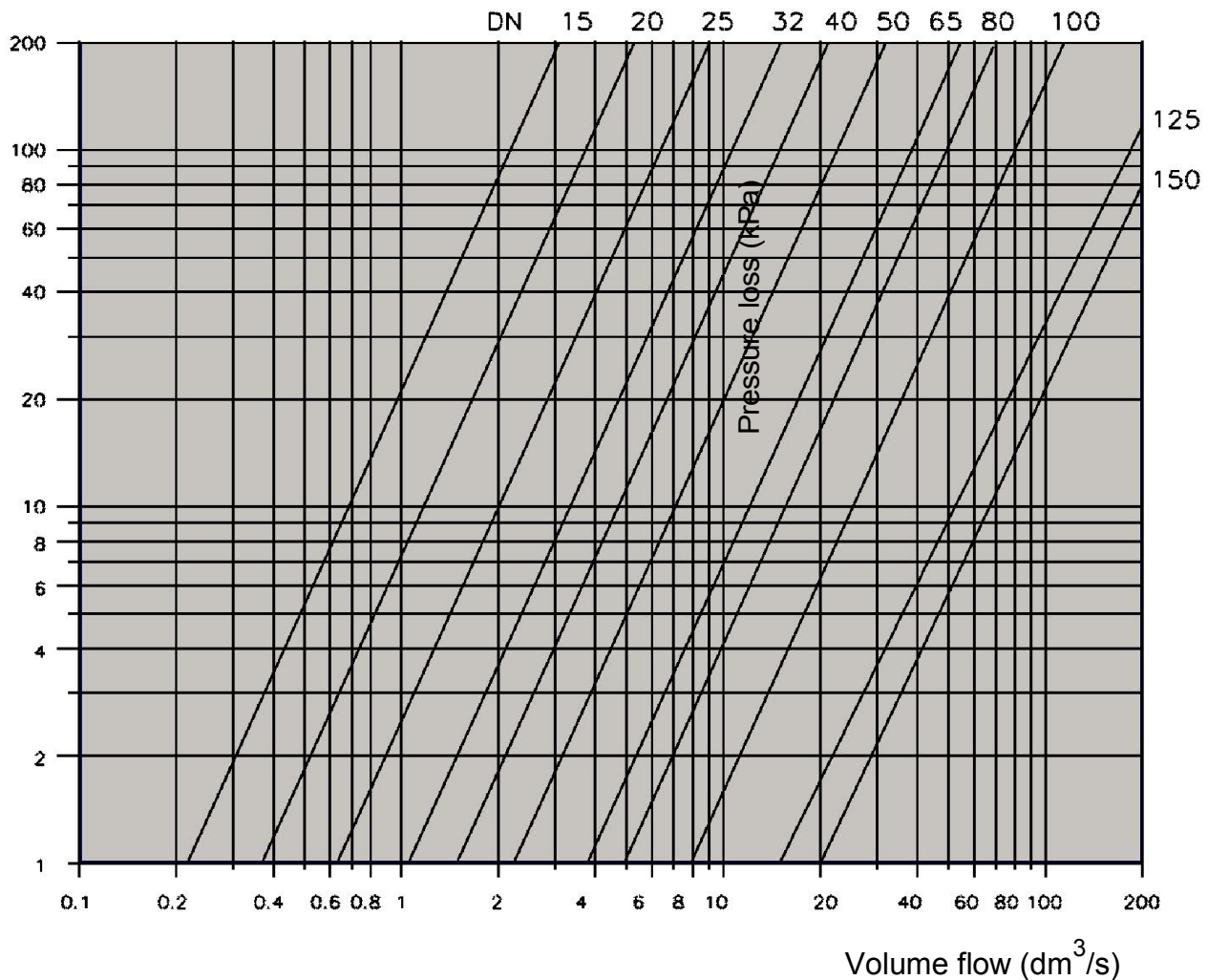
Pressure lost diagram

Strainer net dimensions

filter mesh 0,6 x 0,6 mm

wire diam. 0,25 mm

perforation ratio approx. 40 %

free flow area minimum 6 times pipe bore area