



## HÖGFORS BUTTERFLY VALVE, WAFER PATTERN

### Series

31000, 31001, 31002,  
31100, 31101, 31102,  
31200, 31201, 31202,  
41000, 41001, 41002,  
411, 41101, 41102.



## INSTRUCTION FOR INSTALLATION, USE AND MAINTENANCE

### 1. Overview

Read these instructions carefully before starting the valve installation and start-up work. Safe keep the instructions in the proximity of the valve for easy access by the valve operators.

**HÖGFORS OY takes no responsibility for any damage caused by the valve's incorrect transportation, handling, installation or use.**

**The non-leakage warranty exclusively applies to the valves that are provided with a manual gear or an actuator installed at the manufacturer's factory, provided that the manual gear or actuator in question has not been removed or adjusted by the user.**

### 2. Marking

The valve's identification shield is attached to the actuator attachment flange in the valve frame. The shut-off seal is located on the opposite side of the frame, seen from the identification shield.

The marking groove on the shaft end indicates the valve disc position. The valve closes clockwise and opens counter-clockwise, by turning 90 degrees in both directions.

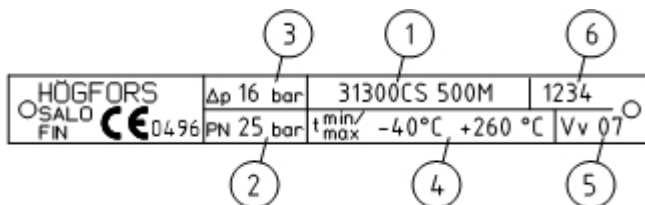

Fig. 1: Product identification shield

Valve manufacturer.

1. Valve type
2. Nominal pressure
3. Max shut-off pressure difference
4. Temperature max / min
5. Year of manufacture
6. Serial number

### 3. Receiving, storage and transportation

During the receiving inspection, check that the valve and its accessories are free from any transportation-induced damage. During storage, the valve must be protected against sand, dust and any other impurities. Avoid long-term storage of the valve outdoors exposed to the effects of rain, sunlight or frost.



When hoisting the valve, always use lifting straps threaded through the lifting lugs and around the valve's upper neck. Hoisting the valve with the lifting straps threaded around the actuator is forbidden. Use special caution when hoisting, transporting and installing the valve. The actuator's centre of gravity may deviate from the valve centre line. This may tilt the valve and actuator during lifting. Even minor impacts may damage the actuator or change the actuator's or valve's adjustments.

#### 4. Installation.

Please check the type of neck-welded flange in Production Card.

Make sure that mounting gaskets totally cover contact surfaces.

During installation make sure that flanges and gaskets are coaxial and parallel to each other.

The disk must be in close position during installation.

Check the clearness inside the valve before installation.

The installation order.

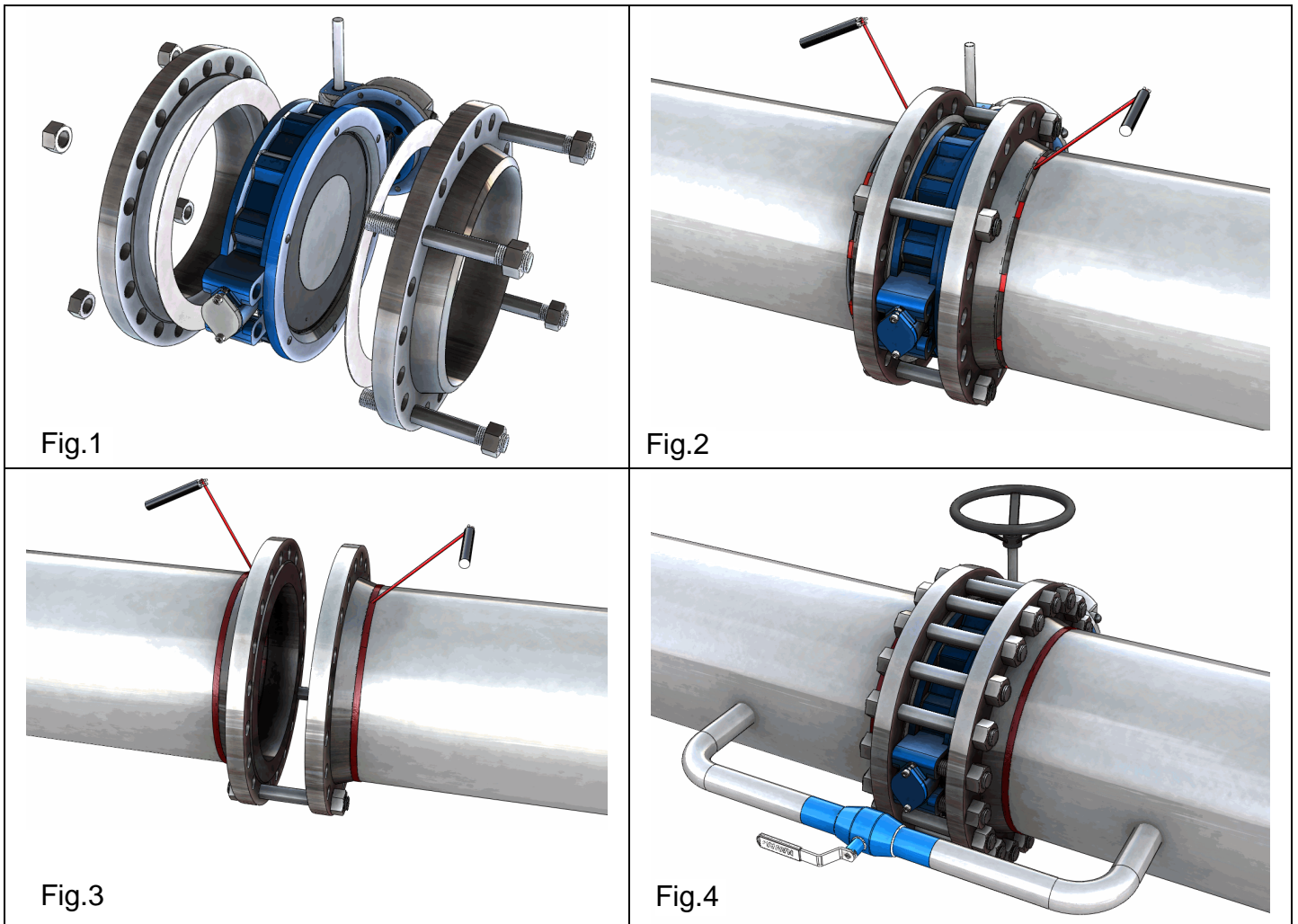

Fig.1. Preassemble the unit of the valve, mounting gaskets and flanges. Connect it by few fasteners and slightly tighten.

Fig.2. Tack weld preassembled unit to the pipeline.

Fig.3. Remove the valve and mounting gaskets from pipeline and make all weld around flanges.



Fig.4. Clean the pipework carefully before installing the valve. Any welding debris and other impurities remaining inside the pipework may damage the valve's shut-off surfaces at a later stage. In this connection, it is also advisable to check that the valve is free from any impurities induced by transportation and storage. During installation make sure that the valve will not be under excess load.

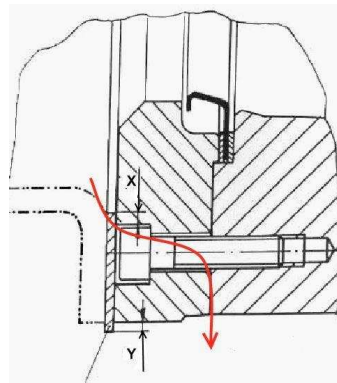
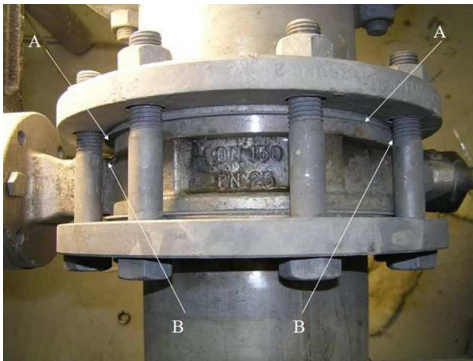

**It is Important that the valve and gasket are central the flanges and the flanges are parallel.**

Otherwise there will be the risk of leakage through holes in counter flange.

The most recommendable installation position for a butterfly valve is with the valve shaft in a horizontal position. Do not install the valve close to a pump or a curved pipe section, due to the turbulent flow that they cause. The flow must be laminar at the valve.

The pipes must be provided with appropriate support. An inadequately supported section of pipework will cause excessive stress on the valve, possibly resulting in leakage from the shut-off surfaces.

Pipework temperature variations will cause thermal contractions and expansions which must be allowed to occur freely, with the aid of bellow-type compensators, for example. Without these, or other similar solutions, pipework expansions will excessively burden the joints.

Do not install the valve into the lowest and highest parts of pipeline.

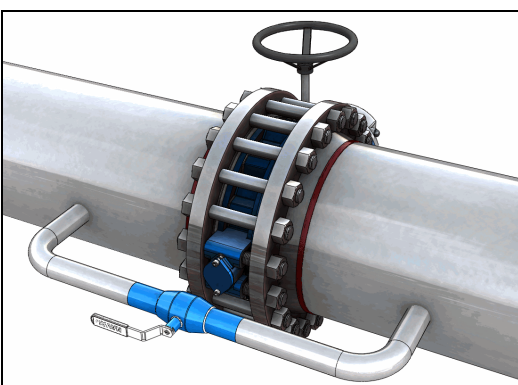

Fill the pipework via the by-pass valves. Install a by-pass valve in order to avoid pressure impacts and to reduce the forces that are caused by opening the butterfly valve under pressure.

The valve disc must not be the final item that separates the content of the pressure vessel (tank and pipeworks) from the environment. However, in cases where this cannot be avoided, secure non-leakage by other means, by welding a solid flange to cover the valve's open end, for example.

Fig. 4: By-pass valve

## 5. Start-up.

Flush the pipework thoroughly once the valve installation has been completed.

All valves delivered to the Customer passed the hydro test at the factory; however, it is necessary to check that there are no faults due to transportation and handling.

If the valve is used for control application then make sure that there is no cavitation mode. Prolonged operation of valve in cavitation mode can lead to erosion valve's parts and destroy it.

It is not recommended to use the first and the last 10% of total stroke of the disk in regulate applications.



If the disk was open at small angle (5°-15°) for prolonged time then open the disk to wider angle (25°-30°) before closing. Thereby the seat area will be flushed up and cleaned. The movable debris from pipeline might stack between valve's body and disk, opened at small angle.

Make sure that the valve-actuator combination functions without problems prior to the start-up procedure.

Always close the valve using the actuator's mechanical travel stops; stay below the maximum torque limit. Avoid the use of excessive force in closing as this cannot improve the valve's tightness.

Valve opens by turning the hand wheel clockwise.

**A valve provided with an electric actuator Auma must always be opened electrically, with the travel limit serving as the closing limit. In an emergency, you may open and close the valve by turning the electric actuator hand wheel.**

In these cases, however, observe that the hand wheel's closing limit has been set to turn the valve disc 2-3 hand wheel revolutions beyond the optimal closed position. This means that the optimal tightness is achieved by turning the hand wheel 2-3 revolutions in the opening direction, starting from the gear's mechanical closing limit.

## 6. Maintenance.

Högfors valves are durable and dependable. An appropriately selected and carefully installed valve will not require maintenance during its life cycle.

Leakage from the valve's shut-off surfaces is often caused by wear and tear, pipework impurities or damage resulting from pressure impacts. Impurities can be removed by opening the valve and allowing the flow to flush the shut-off surfaces clean.

Probability of hydro-stress can be excluded by using by-pass valves.

The scope of maintenance and repair work consists of:

- Cleaning of internal surfaces
- Replacement of main gasket
- Tightening or replacement of stem sealing. This work is possible to carry out when the valve is on-line if the pipeline is not under pressure. For the rest of the repair works, the valve must be taken away from the line.

### 6.1 Manual gear removal and installation

Avoid removing the manual gear from the valve. The manual gear adjustments have been made at the factory so as to secure the valve's tightness. Removing the manual gear requires that the adjustment sequence be repeated.

REMOVING THE MANUAL GEAR IS PROHIBITED WHILE THE VALVE IS UNDER PRESSURE.

#### Removal:

- Turn disk to position "close".
- Mark the manual gear in relation to the valve.
- Turn out bolts between actuator and valve, take out actuator.
- Remove wedges.

#### Installation:

- Install the manual gear with the valve in closed position. Make sure that the manual gear is in the closed position as well.



- Place wedges.
- Install the manual gear in original position. Attach the manual gear to the valve with bolts. Tighten the bolts evenly in a crosswise sequence. Apply locking agent to the bolts.
- Adjust the manual gear as instructed in section 8.2

## 6.2 Manual gear adjustment

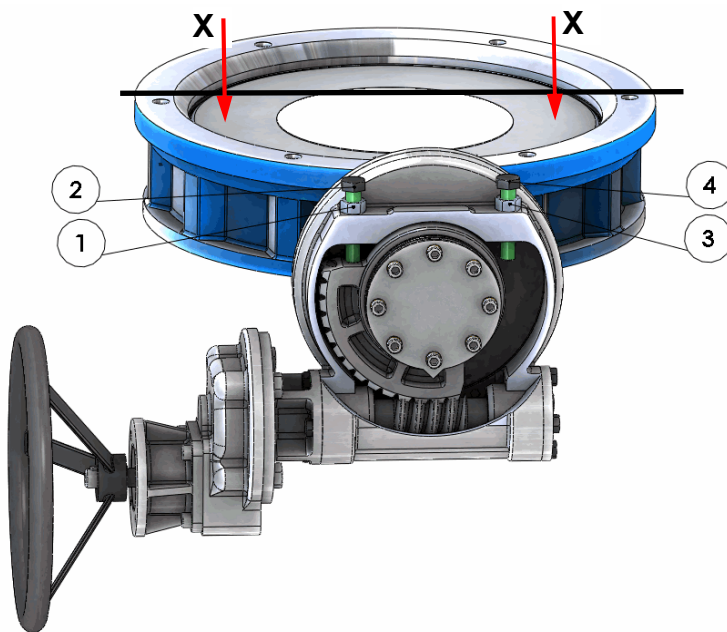

Fig. 6: Measuring distance.

- Open the manual gear travel limit locking bolts 2 and 4, and open adjustment screws 1 and 3
- Turn valve into closed position, so that the disk is parallel to the seal. Right position checked by measuring the distance X from flange of the valve to the disk surface. (Fig. 6). The distance must be equal on both sides of the disk.
- Adjust stopper of “Close” position in manual gear. Turn adjustment screw 1 gently until its movement stops. Tighten locking nut 2.
- Turn the disk to 0 degrees until completely in Open position.

Adjust stopper of Open position in manual gear. Turn adjustment screw 3 gently until its movement stops. Tighten locking nut 4.

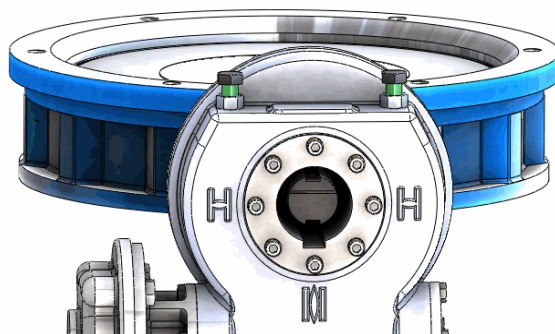

Fig. 7: Marking groove.

The approximate position of the disk can be defined by marking groove on the end of shaft. (Fig. 7). The disk is parallel to the marking groove.

## 6.3 Installation and adjustment of electric actuator onto valve in MF version.

MF version delivered with installed and adjusted worm gear.

**Attention! Changing the factory settings of the gearbox will void the factory warranty for the valve.**

The valve in MF version can be equipped by manual hand wheel or multiturn motorized actuator at customer site or at Högfors factory in accordance to customer demands.

Check the maximum operation torque for this MF valve and do not exceed that value in no circumstances.



Always check in Product card the operation torque for specific valve and gear combination.

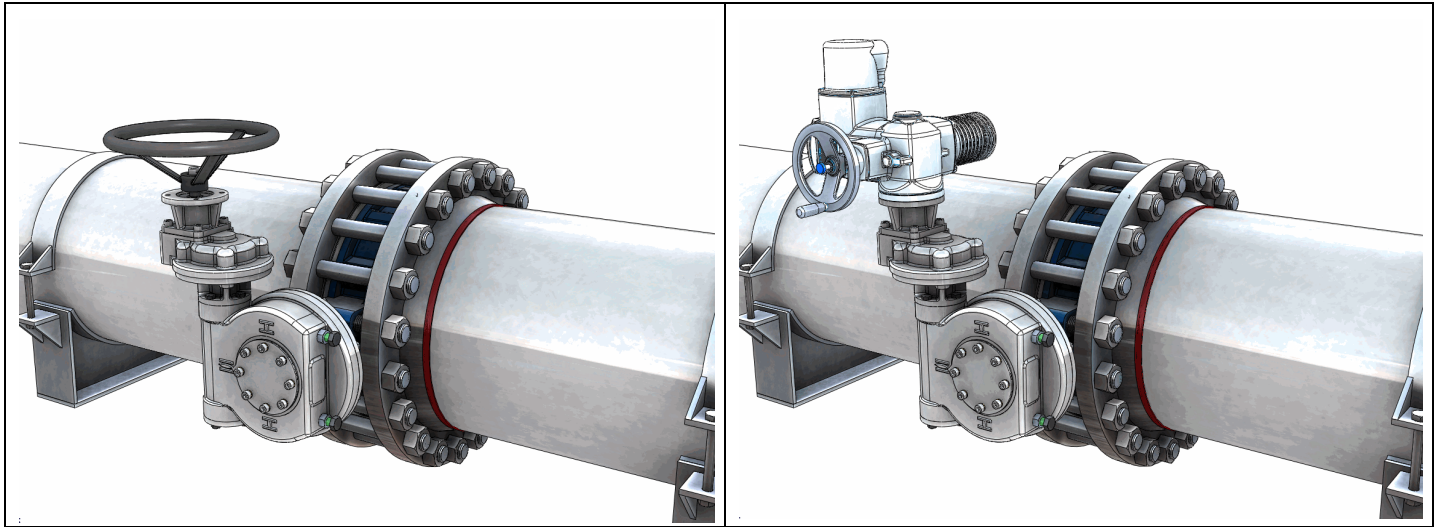

1. Close the disk by hand wheel.
2. Replace the wheel by multiturn motorized actuator.
3. Set the torque limits to value given by valve's producer. Connect wires and make sure that torque limit switches activated.
4. Set position of the disk as position close.
5. Make test run of actuator and make sure travel limits stop the disk just before torque limit. Adjust limit switch if necessary. Correctly adjusted limit switch must activate in advance to torque switch.
6. Repeat steps 4-5 for open position.

#### 6.4 Dismantle and installation of electric actuator (AUMA SA)

Avoid dismantle of the actuator from valve. The adjustment of the actuator has been made at the factory to secure the valves tightens. Dismantling the actuator requires repeated adjustment.

Dismantling the actuator is prohibited while the valve is under pressure or could be under pressure.

##### Dismantle:

- Turn the valve to the closed position.
- Switch off voltage supply to the actuator.
- Loosen the actuator attachment bolts and pull actuator out.
- It is necessary to remove the actuator clutch piece, for example, in connection with shaft seal replacement.
- Mark the clutch piece height on the shaft.
- Loosen the locking screw, and pull the clutch piece off the shaft.
- Remove the wedges.

##### Installation:

- During installation, the valve must be in closed position. Make sure that the actuator itself is in closed position as well.
- Place the wedges. Attach and lock the actuator clutch piece on the valve shaft at its original height.



- Install the actuator to the valve. Attach the actuator to the valve by bolts. Tighten the bolts evenly in a crosswise sequence. Apply a locking agent to the threads.
- For additional instructions, see the manual supplied with the actuator.
- Adjust actuator as instructed in section 6.4.

## 6.5 Electric actuator adjustment.

Use the actuator hand wheel to turn the disk to the half-open position, and check that the valve disk moves in the correct direction when using the switches.

For detailed instructions concerning the actuator's adjustment see the manual supplied with the actuator.

The actuator's adjustment is correct if the entire tooling list below has been done and checked:

1. The limit switcher in the closed position must stop the turning of the disk when the disk is parallel to the seal. Ensure the correct position of the valve disk by measuring distance "X" (Figure. 6). The measure must be the same on both sides of the disk.
2. The torque switchers are adjusted at the values set by the valve's manufacturer (contact the valve vendor or manufacturer for details).
3. The mechanical stopper in the open position is adjusted so that the actuator hand wheel still has 2-4 revolutions from the open position of the limit switcher until the contact with the stopper.
4. The limit switcher in the open position must stop the turning of the disk when the disk is 90 degrees to the seal. At the same time there must be free gap of 2 - 5 revolutions of the hand wheel from the limit switcher till the mechanical stopper.

Non fulfillment of listed adjustments may cause the valves damage or block the actuator.

## 6.6 Other actuators

For detailed instructions concerning actuator removal, installation and adjustment, contact your supplier or manufacturer.

## 6.7 Tightening the valve stem seal

Tightening the valve stem seal is included in regular maintenance. Avoid excessive tightening. The sufficient tightness level is reached when the leakage stops. The tension screws are indicated by number 21 in the exploded view attached.

## 6.8 Valve stems seal replacement

Prior to commencing the replacement procedure, check that the pipework is pressure-free.

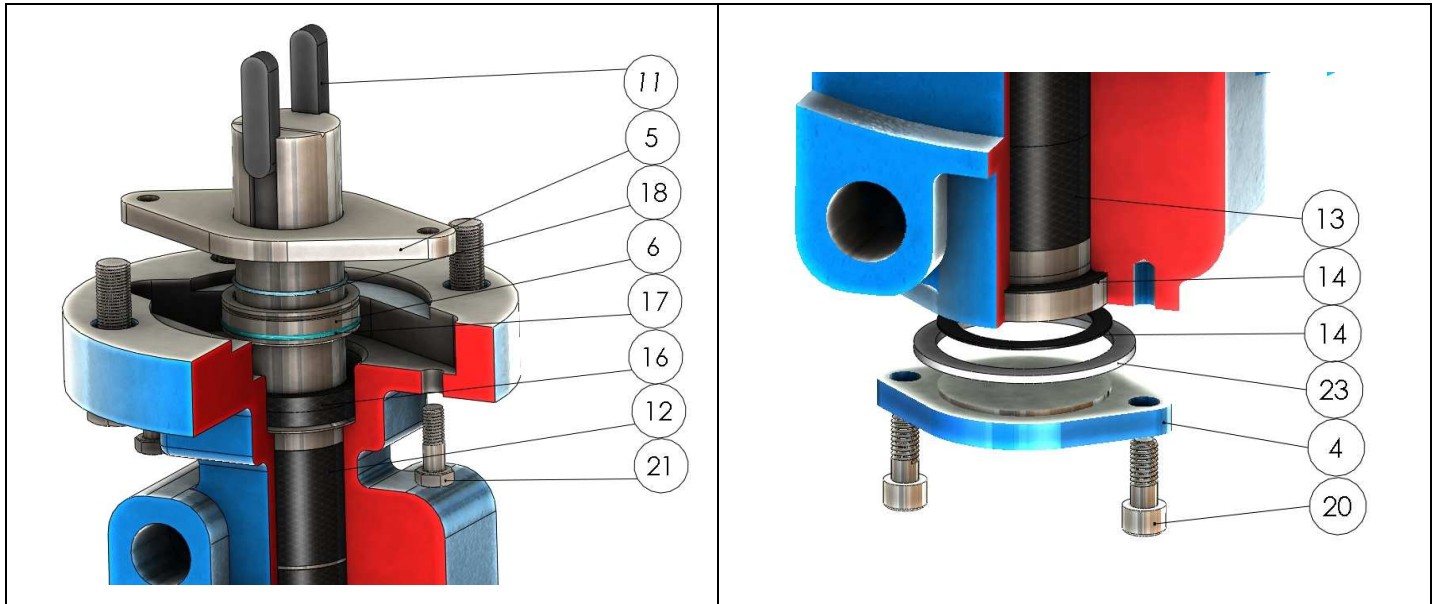

#### Disassembling:

- Remove the actuator and wedges 11.
- Remove hexagon screws 21.
- Remove seal flange 5.
- Lift out shaft seal bushing 6.
- Remove O-rings 17 and 18 from shaft seal bushing 6.
- Remove shaft seals 16.
- Remove screws 20.
- Pull out cover 4 and seal 23, with holding bearing 14.

#### Installation:

- Carefully clean all surfaces. Prior to commencing the installation work, check that there are no sharp edges on the valve shaft that could damage the O-rings and sealing.
- Installation starts from the side of the bottom cap 4. During installation of bearing 14, please note that reinforcement net must be on bottom cap 4 side.
- Place the shaft seals 16 onto the shaft and press them into place.
- Place the O-rings 17 and 18 on the shaft bushing 6 and press it into place. Attach seal flange 5 using hexagon screws 21.
- Install and adjust the manual gear or actuator as instructed above.

#### 6.9 Shut-off seal replacement

Prior to a shut-off seal replacement, remove the valve from the pipework.

It is not necessary to remove the actuator for a shut-off seal replacement.

Turn the valve disc to the closed position.



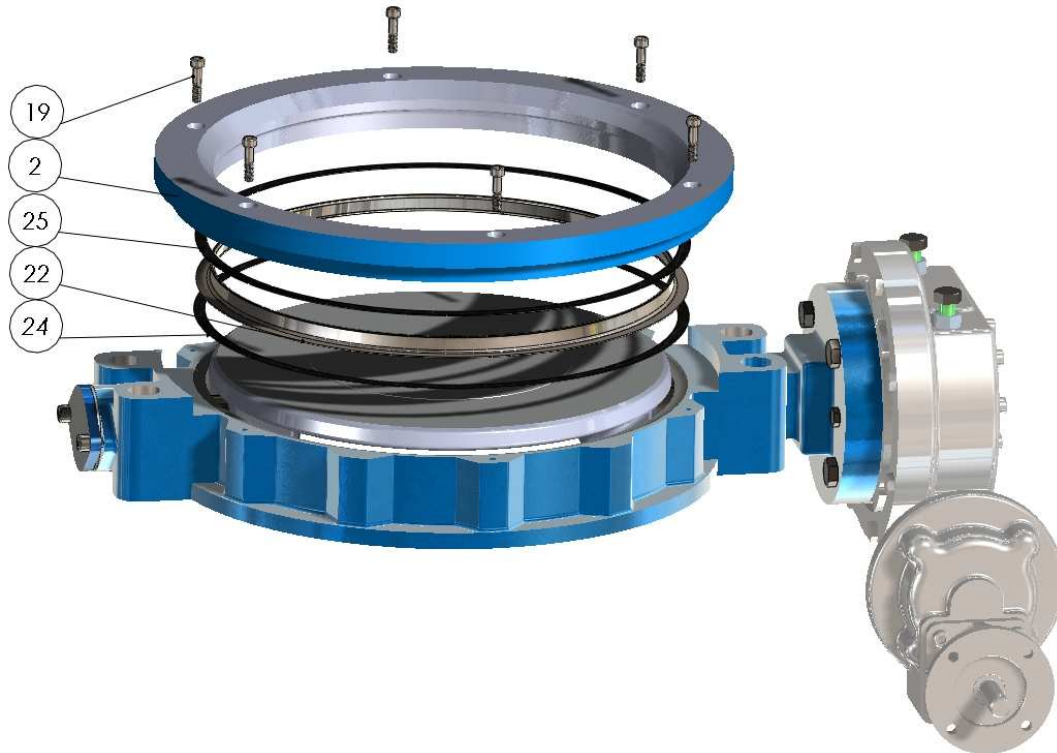

#### Disassembling of CS seal:

- Remove hexagon screws 19 and retaining ring 2.
- Remove shims 24, 25 and seal 22. Note that new shims must have the same thickness as the old ones.

#### Installation:

- Prior to installation of new parts clean carefully all surfaces of frame, disk and retaining ring. Check the condition of sealing surfaces before starting the installation work.
- Keep the valve disk in closed position during the shut-off seal replacement procedure.
- Place on the shims 24, 25 and seal 22.
- Install the retaining ring 2.
- Tighten all hexagon screws 19 evenly in a crosswise sequence.

#### Replacement of PTFE seal (TS):

- Remove hexagon screws 19 and retaining ring 2.
- Remove PTFE seal 22.
- Clean carefully all surfaces of frame, disk and retaining ring. Check the condition of sealing surfaces prior to starting the installation work.
- Install new seal. Disk should be in partly open position.
- Place retaining ring 2.

Tighten all hexagon screws 19 evenly in a crosswise sequence.



## 7. Spare part kit for order.

Set for seat ring replacement:

- Seat ring, pos 22,
- Shim, pos 24 and 25

Set for stem sealing:

- Box packing, pos 16 – 2 pcs,
- O-ring, pos 17 and 18,

## 8. Standard materials. Refer to Appendix 1.

	Part	Material	
		310,311, 31200	410, 411
1	Body	Cast carbon steel GP240GH/ WCB	St. steel ASTM A351 CF8M
2	Counter flange	Carbon steel P265GH	St. steel ASTM A351 CF8M, 1.4404
3	Disk	Stainless steel 1.4408, ASTM A351 CF8M	
4	Subshaft cover	Carbon steel	St. steel 1.4436
5	Gland	Stainless steel 1.4404	
6	Shaft seal bushing	Stainless steel 1.4404	
7	Stem	Stainless steel 1.4460 / 1.4418	
8	Subshaft	Stainless steel 1.4406 / 1.4418	
10	Conical pins	Stainless steel 1.4462	
11	Key	Carbon steel	
12	Stem bearing	PTFE on stainless steel net	
13	Subshaft bearing	PTFE on stainless steel net	
14	Bearing plate	PTFE on stainless steel net	
15	Back-up-ring	Stainless steel 1.4404	
16	Box packing	Graphite	
17,18	O-ring	FPM, not fitted in steam version	
19	Socket screw	Stainless steel ISO 3506 A4-80	
20	Socket screw	Stainless steel ISO 3506 A4-80	
21	Hexagonal screw	Stainless steel ISO 3506 A4-80	
22	Seat ring	Hard chrome plated stainless steel AISI 904L or PTFE+C	
23	Bottom cover gasket	Carbon Fibre SFS5811, Graphite for steam version	
24, 25	Shim	Carbon Fibre SFS5811, Graphite for steam version	



### APPENDIX 1: List of parts and standard materials.

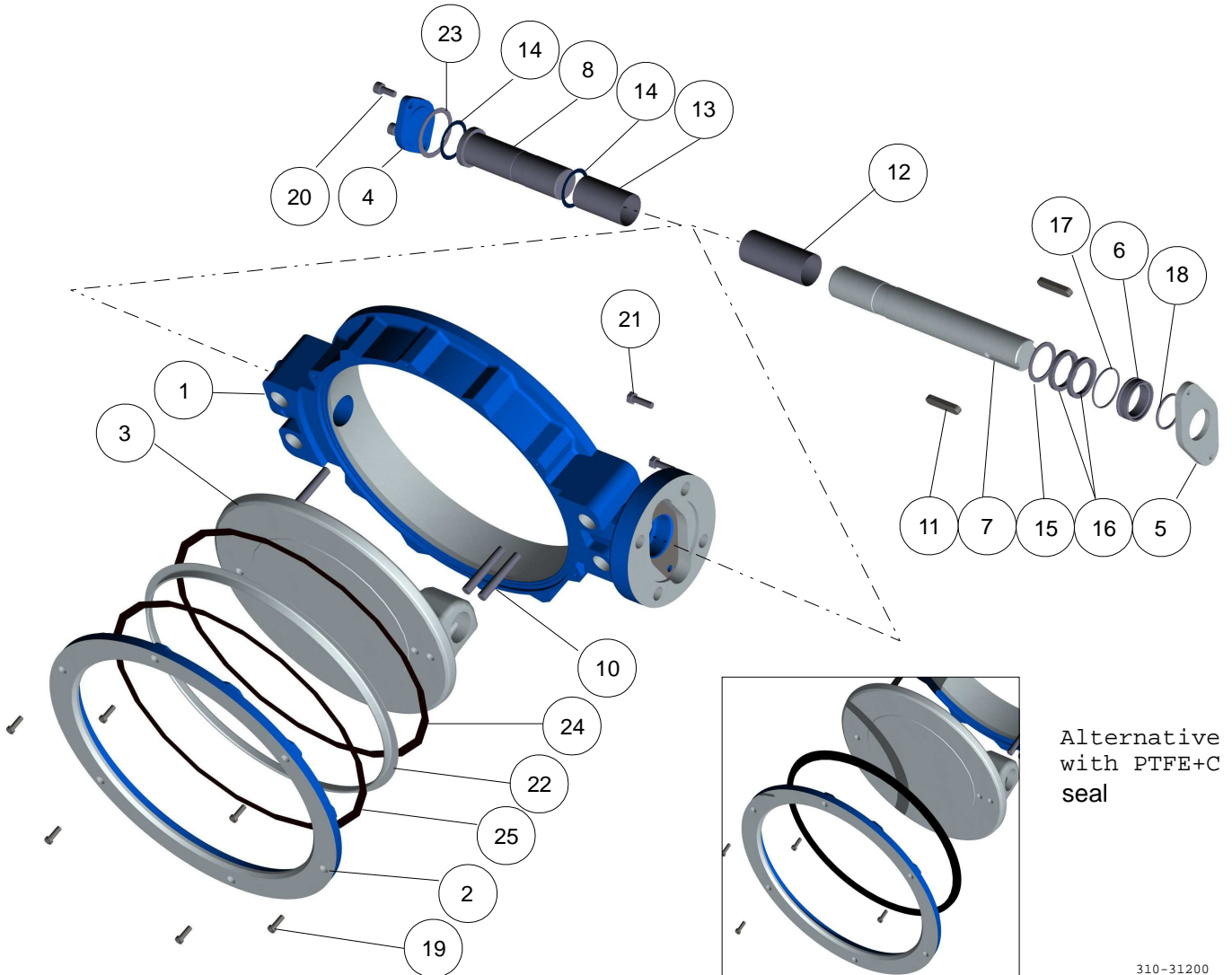

310-31200